

Volume

2

DOE-2.2

Building Energy Use and Cost Analysis Program

Volume 2: Dictionary

December 2006

LAWRENCE BERKELEY NATIONAL LABORATORY
JAMES J. HIRSCH & ASSOCIATES

DOE-2.2 BUILDING ENERGY USE AND COST ANALYSIS PROGRAM

Volume 2: Dictionary

E. O. Lawrence Berkeley National Laboratory
Simulation Research Group
Berkeley, California 94720

James J. Hirsch & Associates
12185 Presilla Road.
Camarillo, CA 93012-9243
Phone 805.553.9000 • Fax 805.532.2401
Copyright ©1995-2006 James J. Hirsch

Acknowledgements

DOE-2.2, both the program and its documentation, are based upon earlier versions of DOE-2. The DOE-2 family of programs was created primarily through a partnership between James J. Hirsch & Associates (JJH) and Lawrence Berkeley National Laboratory (LBNL) with additional contributions, over a twenty five year period, from a large number of individuals and institutions around the world. Support for the continued development of DOE-2, over its two decades of wide distribution, has come from many public and private agencies, companies and educational institutions around the world. The primary support for DOE-2 development, however, has come from public funds provided by the United States Department of Energy (USDOE) and the United States electric and gas utility industry; particularly the USDOE Office of Energy Efficiency and Renewable Energy Building Technologies Program, Southern California Edison Company's Energy Efficiency Division, and the Electric Power Research Institute's Customer Systems Division.

Authorship of the DOE-2.2 program components and documentation is an ongoing team effort that has its roots in previous versions going back over twenty-five years and we expect will continue into future decades. The contributions to DOE-2, both directly as authors and indirectly in the form of advice, comment and testing or feedback, are too numerous to catalog here; however, the primary authors are mentioned below in alphabetical order. Currently, and over the past decade, Marlin Addison, Scott Criswell, Steve Gates, Jeff Hirsch, and Kevin Madison, as consulting staff for JJH, are the major contributors to DOE-2.2. Fred Buhl, Ender Erdem, Kathy Ellington and Fred Winkelmann, as staff members of the Environmental Energy Technologies Division's Simulation Research Group at LBNL, were major contributors to the initial version of DOE-2.2. The primary contributors to the previous versions of DOE-2 (2.1E, 2.1D, 2.1C, etc) were Fred Buhl, Ender Erdem, Kathy Ellington, Steve Gates, Jeff Hirsch and Fred Winkelmann, as LBNL staff and Steve Gates and Jeff Hirsch as consulting staff for JJH.

The authors of DOE-2.2 also wish to acknowledge many persons who, apart from the financial support provided by their organizations, have provided vision and insight that has been instrumental to the ongoing support of the DOE-2 family of products, including DOE-2.1, DOE-2.2, PowerDOE and eQUEST. In particular we express our thanks to Gregg Ander, and his staff, and Janith Johnson, and her staff, at Southern California Edison Company.

Table of Contents

ACKNOWLEDGEMENTS	I
TABLE OF CONTENTS	II
OVERVIEW	1
BUILDING DESCRIPTION LANGUAGE	3
ABORT	4
COMPUTE.....	5
DIAGNOSTIC.....	6
END	8
HOURLY-REPORT	9
INPUT.....	11
LIKE (KEYWORD)	12
PARAMETER	14
PARAMETRIC-INPUT	16
REPORT-BLOCK.....	17
SCHEDULE DAY-SCHEDULE WEEK-SCHEDULE	18
DAY-SCHEDULE	19
DAY-SCHEDULE, Reset.....	21
Daytime keywords.....	22
Night time keywords.....	22
WEEK-SCHEDULE.....	23
SCHEDULE	25
Nesting of Schedules.....	26
SCHEDULE-PD DAY-SCHEDULE-PD WEEK-SCHEDULE-PD.....	28
DAY-SCHEDULE-PD	28
WEEK-SCHEDULE-PD	28
SCHEDULE-PD	29
RUN-PERIOD	30
RUN-PERIOD-PD.....	31
SET-DEFAULT	32
STOP	33
TITLE.....	34
ENVELOPE COMPONENTS	35
BUILD-PARAMETERS.....	36
BUILDING-SHADE	39
CONSTRUCTION.....	42
DESIGN-DAY.....	46
DOOR	49
Fins and Overhangs.....	50
EXTERIOR-WALL OR ROOF	52
FIXED-SHADE.....	58
FLOOR	60
GLASS-TYPE.....	62
HOLIDAYS	65
INTERIOR-WALL.....	67
LAMP-TYPE.....	72
LAYERS.....	74
LIGHTING-SYSTEM	77
LTG-CALC-METHOD=LUMINAIRE-LAMP.....	77
LTG-CALC-METHOD=LUMENS-POWER.....	79
LOADS-REPORT	80
LUMINAIRE-TYPE	84
Luminaire Dirt Depreciation	85
Coefficient of Utilization	87
MATERIAL.....	88
TYPE=PROPERTIES.....	88
TYPE=RESISTANCE.....	88

POLYGON	89
SITE-PARAMETERS	96
<i>Wind Speed Modification Keywords</i>	97
SPACE	104
<i>General</i>	104
<i>Geometry</i>	106
<i>Occupancy</i>	109
<i>Overhead Lighting</i>	110
<i>Distribution of Heat from Overhead Lights</i>	114
<i>Daylighting</i>	116
<i>Task Lighting</i>	127
<i>Equipment</i>	127
<i>Space Heat Sources</i>	129
<i>Infiltration</i>	130
<i>Weighting-Factor Related Keywords</i>	132
<i>Input Functions</i>	132
TROMBE-WALL-NV	133
UNDERGROUND-WALL UNDERGROUND-FLOOR	135
WALL-PARAMETERS	138
<i>TROMBE-WALL-NV keywords</i>	138
<i>Sunspace INTERIOR-WALL air flow keywords</i>	138
WINDOW	142
<i>Skylight Glass and Daylighting Properties</i>	144
<i>Describing a Window Using Layers</i>	147
<i>Setbacks, Fins and Overhangs</i>	150
<i>Window Coverings</i>	151
<i>Window Frames and Skylight Curbs</i>	155
<i>Window Blind Control</i>	159
<i>Switchable Glazing</i>	160
<i>Miscellaneous Window Keywords</i>	163
<i>Input Functions</i>	163
WINDOW-LAYER	165
<i>Solar radiation keywords</i>	168
<i>Visible radiation keywords</i>	168
<i>Infrared radiation keywords (apply only to glass or blind layers)</i>	169
<i>Slat and blind keywords (apply only to blind layers)</i>	169
<i>Keywords for a glass, blind, or gap layer</i>	171
<i>Gap layer keywords (defaults shown are for argon)</i>	171
<i>How to Model Pull-Down Shades</i>	172
HVAC COMPONENTS	173
BOILER	174
<i>Boiler Design and Operating Capacity</i>	174
<i>Boiler Energy Consumption</i>	175
<i>Attachment to Hot-Water Loop</i>	177
<i>Miscellaneous</i>	178
CHILLER	179
<i>Rated vs. Design Conditions</i>	181
<i>Chiller Design and Operating Capacity</i>	184
<i>Chiller Energy Consumption</i>	185
<i>Attachment to Chilled-Water Loop</i>	190
<i>Attachment to Hot-Water Loop</i>	191
<i>Water-Cooled Condenser</i>	192
<i>Remote Air-Cooled Condenser</i>	194
<i>Remote Evaporatively-Cooled Condenser</i>	196
<i>Heat Recovery to Hot-Water Loop</i>	199
<i>Heat-recovery chiller (ELEC-HTREC)</i>	200
<i>Absorption Chillers (ABSOR-1, ABSOR-2, and GAS-ABSOR)</i>	200
<i>Gas-Fired Absorption Chiller (GAS-ABSOR)</i>	200
<i>Engine-Driven Chiller (ENGNE)</i>	201
<i>Air-to-Water Heat-Pump (HEAT-PUMP, AIR-COOLED)</i>	201
<i>Well-Water-to-Water Heat-Pump (HEAT-PUMP, WATER-COOLED)</i>	204
<i>Loop-to-Loop Heat-Pump (LOOP-TO-LOOP-HP)</i>	207
<i>Chiller Water-Economizer</i>	213
<i>Miscellaneous</i>	215
CHW-METER	216
CIRCULATION-LOOP	219
<i>Loop Fluid and Flow Characteristics</i>	221
<i>Secondary Loop to Primary Loop Connection</i>	223
<i>Loop Availability</i>	225
<i>Loop Temperature Control</i>	228

Loop Circulation Pumps.....	231
Loop Thermal Losses.....	232
Process Load Attached to a Loop.....	235
Loop Auxiliary Load.....	236
CIRCULATION-LOOP and the EQUIP-CTRL Command.....	236
Other Loop Keywords.....	237
CURVE-FIT.....	238
INPUT-TYPE = COEFFICIENTS.....	240
INPUT-TYPE = DATA.....	240
DW-HEATER.....	243
Energy Consumption.....	244
Attachment to DHW Loop.....	246
HEAT-PUMP Water Heater.....	246
Heat Recovery from Superheat.....	246
Space Heating from a Domestic Water Heater.....	247
Miscellaneous.....	247
ELEC-GENERATOR.....	248
Energy Consumption of the Generator.....	249
Exhaust Heat Recovery to a Hot-Water, WLHP, or DHW Loop.....	250
Jacket Heat Recovery to a Hot-Water, WLHP, or DHW Loop.....	251
Heat Rejection to a CW or WLHP Loop.....	251
Steam-Turbine Generators.....	252
Photovoltaic Arrays and Inverters.....	253
Miscellaneous.....	259
ELEC-METER.....	260
Electric generators.....	263
EQUIP-CTRL.....	266
TYPE = COOLING.....	267
Assignment of Thermal Storage Equipment.....	269
Coordinating Equipment Usage with a Chilled-Water Meter.....	270
Other EQUIP-CTRL Types.....	271
Additional EQUIP-CTRL Rules.....	277
FUEL-METER.....	278
GROUND-LOOP-HX.....	280
Simulation of Vertical Wells.....	281
Simulation of Horizontal Loops.....	281
Keywords.....	281
Vertical Well Systems.....	282
Horizontal Well Systems.....	285
Pipe Properties.....	286
Grout Properties.....	287
Ground Properties.....	288
Fluid Properties.....	291
Loop History.....	291
Attachment to a CIRCULATION-LOOP.....	291
Application to a Single Heat Pump.....	292
Integration with a Cooling Tower.....	293
Error Checking.....	293
HEAT-EXCHANGER.....	296
HEAT-REJECTION.....	299
Number of Cells and Cell Control.....	300
Fan Power Consumption and Control.....	301
Attachment to a CW or WLHP Loop.....	302
OPEN-TWR, OPEN-TWR&HX and FLUID-COOLER.....	304
Open Tower with Heat-exchanger (OPEN-TWR&HX).....	306
Fluid Cooler Spray Pump.....	306
Fluid Cooler Dry-Coil Operation.....	307
Off-Hours Heat Losses in Fluid Coolers and Coil Freeze Protection.....	308
Pan Freeze Protection.....	310
Dry Cooler Performance.....	311
Temperature Control in Cooling Towers.....	311
LOAD-MANAGEMENT.....	314
MASTER-METERS.....	318
Time-Dependent Valuation.....	319
MATERIALS-COST.....	321
PLANT-REPORT.....	323
PV-MODULE.....	326
Sandia/King Algorithm.....	329
Module Reference Conditions.....	330
Expression Values.....	330
PUMP.....	331

STEAM-METER..... 335

SUBR-FUNCTIONS..... 337

SYSTEM 338

Air Flow and Fans 340

Ventilation Air..... 350

Airside Control..... 375

Cooling Equipment..... 384

Heating Equipment..... 399

Staged Flow/Capacity DX cooling/Heating Systems..... 411

Fan Coil and Induction Unit Simulation..... 419

Desiccant cooling units..... 419

Refrigerated Casework 420

Meters..... 426

Zone Terminal Keywords 428

Miscellaneous..... 430

SYSTEMS-REPORT 431

THERMAL-STORAGE 436

Temperature Limits of the Tank..... 436

Attachments to Loops..... 436

Charging and Discharging Parameters..... 437

Thermal Losses of the Storage Component..... 438

ZONE 440

Airflow 442

Cooling Equipment / Sizing 450

Heating Equipment / Sizing..... 452

Temperature Control..... 455

Sunspaces..... 456

Refrigerated Casework 458

Ice Skating Rinks..... 460

Zone Meters..... 464

Miscellaneous 466

ECONOMIC COMPONENTS 467

 BASELINE..... 468

 BLOCK-CHARGE..... 471

 COMPONENT-COST 476

 ECONOMICS-REPORT 478

 POLLUTANT-COEFFS 480

Default Pollution Coefficients by Region 481

 RATCHET 484

 UTILITY-RATE 486

Rate Qualifiers 488

Energy and Demand Charges 490

Taxes and Surcharges 493

Buy/Sell Arrangements 494

Overview

This manual defines all of the commands and keywords in the program's building description language (BDL). The manual has the following organization:

BDL General	General commands and keywords
LOADS	Commands and keywords for the heating and cooling loads calculations
HVAC	Commands and keywords for the mechanical systems and plant calculations
ECONOMICS	Commands and keywords for the economics calculations (utility rate structures and life-cycle cost information)

Within each section, commands are listed alphabetically. However, keywords associated with a command are not listed alphabetically but instead are grouped according to function.

In the keyword definitions, when two words are separated by a colon, as in

BOILER:CAPACITY

the first word (BOILER) is a command name and the second word (CAPACITY) is the name of a keyword belonging to this command.

The following format is used for a command to show its abbreviation:

COMMAND (abbreviation if one exists)

For example,

EXTERIOR-WALL (E-W)

The following format is used for a keyword to show its abbreviation:

KEYWORD (abbreviation)

For example,

TEMPERATURE (T)

Three other manuals are available that are designed to be used with this *DOE-2.2 Dictionary*. The *DOE-2.2 Basics* is an introduction to using the program. It covers only the most commonly-used commands and keywords. The *DOE-2.2 Topics* describes how to model different aspects of a building. It is organized by topics, such as "Daylighting" and "Thermal Energy Storage," that, in general, span a range of commands and keywords. The *DOE-2.2 Libraries & Reports* contains listings of all of the components in the Library, descriptions of all output reports, and tables of user-defined hourly report variables.

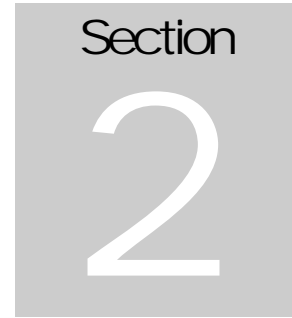

Building Description Language

This section describes general commands and keywords that act globally throughout the program.

ABORT

The ABORT command specifies what level of diagnostic in following instructions is considered severe enough to prevent execution of the simulation. The instruction takes the form

```
ABORT IF Level ..
```

or simply

```
ABORT Level ..
```

where Level is a code-word indicating what level of diagnostic is to be considered fatal:

ERRORS	Diagnostics deal with problems in the input that must be corrected before the simulation will execute.
WARNINGS	Diagnostics are concerned with input data that can be used in the simulation but are probably erroneous (such as a temperature input of 700 instead of 70.0).
CAUTIONS	Diagnostics are much less severe than WARNINGS messages and deal with questionable input value that do not significantly affect the results of the simulation. This is the default level.

Example input:

```
ABORT IF WARNINGS ..
```

Rules

1. If ERRORS, only error messages are fatal. If WARNINGS, error and warning messages are fatal. If CAUTIONS, error, warning, and caution messages are fatal.
2. The ABORT instruction may be entered more than once to change the abort level.
3. The ABORT instruction may be used as a control instruction (i.e., it need not appear between an INPUT instruction and an END instruction).

COMPUTE

The COMPUTE command directs the program to execute a simulation using the input data provided between the preceding INPUT (or PARAMETRIC-INPUT) and END commands.

The instruction takes the form

```
COMPUTE .. (simulate LOADS, HVAC, and ECONOMICS if present)
```

or

```
COMPUTE ECONOMICS.. (simulate just ECONOMICS)
```

For examples, see the Parametric Run topic in the *DOE-2.2 Topics*.

Rules

1. If COMPUTE is not entered, only error checking of input data will occur and no simulation will take place.
2. All input data are processed before any simulation occurs. Thus, if a fatal error is detected no simulation will occur.
3. A COMPUTE command may not occur between an INPUT command and an END command.

DIAGNOSTIC

DIAGNOSTIC command specifies various options available to indicate problems in your input or to give printing instructions.

The instruction takes the form

```
DIAGNOSTIC Option ..
```

where Option is one or more code-words that specify desired diagnostic options:

ERRORS	Only error messages are printed.
WARNINGS	Error and warning messages are printed.
CAUTIONS	Error, warning, and caution messages are printed. This is the default value.
DEFAULTS	Same as CAUTIONS, plus all default values used are printed.
COMMENTS	Same as DEFAULTS, plus informative messages are printed.
SINGLE-SPACED	Input is echoed single-spaced. (This is the default value.)
DOUBLE-SPACED	Input is echoed double-spaced.
ECHO	Input is echoed to the output listing. (This is the default value.)
NO-ECHO	Input is not echoed. However, when diagnostic messages are printed, the previous line of input is also printed. All control instructions are echoed.
NO-LIMITS	The program ignores the keyword maximum and minimum allowable values in its input checking and does not print CAUTIONS messages for input values beyond their normal range. You should be extremely careful when specifying NO-LIMITS because (1) erroneous data can escape this important checking process and (2) some program calculations are not accurate beyond their allowable ranges.
LIMITS	The program uses its built-in ranges for checking user-specified keyword values. (This is the default value.)
LIBRARY-CONTENTS	The contents of both the default and user libraries will be printed. No diagnostics are printed with the contents of the library. [Warning: use of this code-word may result in many pages of output]

Example input:

```
DIAGNOSTIC WARNINGS DOUBLE-SPACED ..
```

Rules

1. You may list any number of the above codewords. Avoid inputting contradictory options, such as DIAGNOSTIC CAUTIONS ERRORS.

2. You may change the diagnostic level at any time. For example, to list the BDL comments only for a single EXTERIOR-WALL component, specify DIAGNOSTIC COMMENTS immediately before the exterior-wall definition, and DIAGNOSTIC WARNINGS immediately after.
3. The level chosen from among ERRORS, WARNINGS, CAUTIONS, DEFAULTS, and COMMENTS must be equal to or less than the level specified for the ABORT command. For example, ABORT = CAUTIONS and DIAGNOSTIC = ERRORS are not compatible inputs. Also, if DIAGNOSTIC = ERRORS (or WARNINGS) and ABORT is allowed to default to CAUTIONS (a lower level than ERRORS and WARNINGS), the DIAGNOSTIC instruction itself will get a warning message and the program will abort. This can be avoided by entering an ABORT instruction before the DIAGNOSTIC instruction

END

The END command indicates that all data for a particular INPUT or PARAMETRIC-INPUT have been entered.

The instruction takes the form of simply

```
END ..
```

Once an END .. instruction is encountered, final processing of the input takes place, such as checking for undefined U-names, and unattached children such as pumps, spaces, etc.

If END is omitted, all subsequent instructions will be erroneously interpreted as further input instructions. Each END instruction must be preceded by an INPUT or PARAMETRIC-INPUT instruction.

HOURLY-REPORT

The HOURLY-REPORT command causes the program to print the hourly values of all variables specified in one or more REPORT-BLOCK instructions. These values are to be printed according to the schedule assigned to the keyword REPORT-SCHEDULE.

The simplest form of this instruction is:

```
U-name = HOURLY-REPORT
      REPORT-SCHEDULE = R-S-U-name
      REPORT-BLOCK    = (R-B-U-name) . .
```

where R-S-U-name is the U-name of a SCHEDULE instruction and R-B-U-name is one or more U-names of REPORT-BLOCK instructions.

Rules

1. U-name is required.
2. LIKE may be used (see "LIKE" keyword).
3. Report values will be printed every hour for which the hourly value of the assigned REPORT-SCHEDULE is nonzero. Note that even if DAYLIGHT-SAVINGS = YES, summer hours will not reflect daylight saving time. Therefore, there will be one-hour difference between times appearing in the LOADS Summary Reports and the LOADS Hourly Reports.
4. The U-name(s) assigned to the keyword REPORT-BLOCK must appear within parentheses, even if only one U-name is assigned.
5. The total number of all items in all the REPORT-BLOCKS for an HOURLY-REPORT command cannot exceed sixty (60.)
6. Hourly reports can be printed from the LOADS and HVAC sub-programs. You may mix REPORT-BLOCKS from the two subprograms in the same HOURLY-REPORT. However, because these two sub-programs execute sequentially (rather than in the same time step), only the variables in the report-blocks applicable to a given subprogram will print in the report following that subprogram's execution. In other words, if you mix variables from the two subprograms in the same report, the program will output the report twice; once for the LOADS variables, and again for the HVAC variables.
7. The keywords REPORT-BLOCK and REPORT-SCHEDULE may be abbreviated to R-B and R-SCH, respectively.

Note: A program weather year contains 365 days. When the Weather Processor is run on a weather tape for a leap year, the first 365 days it encounters become the weather year and February is assumed to have 28 days. As a result, the weather for all days after February 28 will be displaced by one day of the week, i.e., the weather for February 29 becomes the weather for March 1, and March 1 is assumed to occur one day earlier in the week than the calendar for that year would indicate. The data for December 31 on the original weather file is ignored.

Example input:

```
HR-1 = HOURLY-REPORT
      REPORT-SCHEDULE = RS-JAN
      REPORT-BLOCK    = (RS-1) . .
```

This defines an hourly report named HR-1 that will print values of the variables specified in report block RS-1 when the schedule named RS-JAN has an hourly nonzero value.

REPORT-SCHEDULE

Takes the U-name of a schedule, of TYPE = ON/OFF, whose hourly values determine if the report will be printed that hour.

REPORT-BLOCK

Takes a list of U-names of REPORT-BLOCK commands, which determines what variables will be included in the hourly report.

INPUT

INPUT is a required command that indicates that the instructions to follow contain input data. INPUT should be the first command in your input file. Generally, the data is input for a complete LOADS, HVAC, and ECONOMICS simulation; however, ECONOMICS input can be left out and/or specified separately. The maximum number of INPUT plus PARAMETRIC-INPUT commands in one input file should be 100.

Examples:

```
INPUT FOR DOE-2 ..
```

```
INPUT ..
```

```
INPUT FOR ECONOMICS ..
```

Rules

1. FOR is optional
2. INPUT .. is equivalent to INPUT FOR DOE-2 ..
3. In a parametric input, the INPUT instruction should be on a separate line.

INPUT-UNITS

Keyword defaults to what was specified for the previous INPUT command. For the first INPUT, the default is ENGLISH. INPUT-UNITS takes a code-word that determines whether the input is in English or metric units. ENGLISH gives English input units; METRIC gives metric input units.

OUTPUT-UNITS

Keyword defaults to what was specified for the previous INPUT command. For the first INPUT, the default is ENGLISH. OUTPUT-UNITS takes a code-word that determines whether the output is in English or metric units. ENGLISH gives English output units; METRIC gives metric output units.

LIKE (KEYWORD)

The LIKE keyword is used to duplicate the user-supplied data input in a previous command; however, in the case of keywords given values with expressions, values are not taken from the previous command but are recalculated by the program for the current command. The value entered for LIKE is the U-name of a previous command of the same type. Any data that differ from the data of the previous command may be specified in the normal manner. For example, the instruction

```
BLUE-ROOM = SPACE
  LIKE          RED-ROOM
  EXCEPT
  WIDTH        = 30.0
  DEPTH        = 20 ..
```

defines a new space named BLUE-ROOM that has all the attributes of a previously-defined space named RED-ROOM, but with different values for its width and depth.

LIKE will duplicate only user-input keywords and keyword values, not program-calculated values. For example, in

```
BROWN-ROOM = SPACE
  LIKE          BLUE-ROOM ..
```

BROWN-ROOM will be assigned a WIDTH of 30 and a DEPTH of 20, but will not assign AREA = 600, the product of 30 and 20.

Rules

1. LIKE may be used only in those instructions having LIKE listed as a valid keyword.
2. If LIKE is used, it must be the first keyword in the instruction.
3. The instruction whose name is used as the value for LIKE must be entered before the instruction containing the LIKE keyword.
4. LIKE only copies information between commands. It does not copy information between building elements that are subsidiary to the commands. For example, if SPACE B is LIKEd to SPACE A then the data for A is applied to B but the walls belonging to A are not applied to B. They must be separately LIKEd. Similarly, if WALL C is LIKEd to WALL D, the data for C is applied to D but the windows or doors in C are not applied to D.
5. The word EXCEPT is optional.
6. Different commands cannot be LIKEd. For example, a DOOR instruction cannot use the U-name of WINDOW as a LIKE keyword value. If a command uses the TYPE keyword, only commands of the same TYPE can be LIKEd.
7. Code-words cannot be used in a LIKE keyword.

If you have specified an incorrect value in an instruction that is subsequently referenced in other instructions with a LIKE keyword, the error diagnostics will not be repeated in the subsequent instructions. This is illustrated in the following example:

```
WINDOW-1 = WINDOW
  . . . .
  HEIGHT           = 5
  WIDTH            = 3
  DEPTH            = 4 ..

***ERROR           DEPTH   UNKNOWN KEYWORD

WINDOW-2 = WINDOW
  LIKE           WINDOW-1 ..

WINDOW-3 = WINDOW
  LIKE           WINDOW-1 ..
```

DEPTH is not a valid keyword for WINDOW; therefore, it was rejected for WINDOW-1 and an error diagnostic was printed. Although WINDOW-2 and WINDOW-3 included the LIKE WINDOW-1, DEPTH = 4 in both cases will be rejected, but the error diagnostic will not be repeated.

PARAMETER

The PARAMETER command is used to designate up to 500 user-specified variables as parameters in parametric runs and to assign them values.

The instruction takes the form

```
PARAMETER
  Name = Value ..
```

where "Name" is the user-specified name of a parametric keyword, and "Value" is the value assigned to that variable in the current simulation. Whenever the name of a parameter is encountered as a value for a keyword, the value of that parameter is substituted for the value for the keyword.

A parameter may have a numeric value or a numeric value multiplied by another value using "TIMES," as shown in the following example:

Example input:

Window width for W1 is 10 ft and W2 is 11 ft

```
INPUT ..
  ....

PARAMETER
  P1                = 10 ..

  ....

W1 = WINDOW
  WIDTH              = P1 ..

  ....

W2 = WINDOW
  WIDTH              = P1 TIMES 1.1 ..

  ....

END ..

COMPUTE ..

STOP ..
```

Parameters may also have non-numeric values. Whenever the value being input for a non-numeric keyword (such as a keyword that takes a U-name or code-word as a value) is detected to be a parameter, the value of that parameter is used as the value for the keyword. This is illustrated in the following example:

Example input:

```
PARAMETER
  P2                = COLDEST
  P3                = WS1 ..
```

```

.....
SC-1 = SYSTEM
  TYPE                = PVAVS
  .....
  HEAT-CONTROL        = P2 ..
  .....

SCH-1 = SCHEDULE
  .....
  WEEK-SCHEDULE       = P3 ..

```

The above causes the value COLDEST to be assigned to HEAT-CONTROL and WS1 to be assigned to WEEK-SCHEDULE.

Rules

1. Although a "Name" may be longer than 32 characters, only the first 32 characters are used.
2. A parametric keyword U-name must be unique from all other parametric keyword U-names and non-parametric keyword U-names. "Name" must be unique; i.e., not the same as another "Name" or any command U-names.
3. A parameter must be defined with a PARAMETER instruction before it is used in a keyword value assignment.
4. If the TIMES feature is used, the word TIMES must appear on the same line as the parametric keyword.
5. The value after the word TIMES must be a number; it cannot be another parameter name.

PARAMETRIC-INPUT

The data following this command may consist only of parametric modifications to data entered between the previous INPUT and END instruction sequence.

The instruction takes the form

```
PARAMETRIC-INPUT FOR DOE-2  ..  
PARAMETRIC-INPUT FOR ECONOMICS  ..
```

PARAMETRIC-INPUT FOR ECONOMICS refers to the data from the previous INPUT FOR ECONOMICS.

Rules

1. There must be a previous INPUT command FOR DOE-2 or FOR ECONOMICS, as appropriate.
2. The word FOR is optional.
3. The only instructions that may be entered between a PARAMETRIC-INPUT instruction and the next END instruction are ABORT, PARAMETER, DIAGNOSTIC (or LIST) and additional TITLE instructions (beyond those used in the original simulation run).
4. If TITLE is going to be changed in each PARAMETRIC-INPUT (a good idea), the first, base title should be input before the first INPUT command. See the example in the Parametric Run topic in the *DOE-2.2 Topics*.

INPUT-UNITS

INPUT-UNITS defaults to whatever was specified for the previous INPUT or PARAMETRIC-INPUT command.

OUTPUT-UNITS

OUTPUT-UNITS defaults to whatever was specified for the previous INPUT or PARAMETRIC-INPUT command.

REPORT-BLOCK

The REPORT-BLOCK command is used to specify a group of variables to be printed in an hourly report (see HOURLY-REPORT command).

Example input:

```
RB-1 = REPORT-BLOCK
      VARIABLE-TYPE   = BUILDING-LOADS
      VARIABLE-LIST   = ( 1,19 ) ..

HR-1 = HOURLY-REPORT
      REPORT-SCHEDULE = RS-1
      REPORT-BLOCK    = (RB-1) ..
```

This would cause the building sensible heating load and building sensible cooling load to be printed every hour for which schedule RS-1 is nonzero.

VARIABLE-TYPE

Required. Takes a code-word that indicates the type of variable contained in this block. Allowed values are tabulated in the *DOE-2.2 Libraries & Reports*.

VARIABLE-LIST

Takes a list of code-numbers indicating which variables of the type specified by VARIABLE-TYPE are to be included in this block. Variables and their corresponding code-numbers are described in the *Libraries & Reports* document.

Rules

1. U-name is required.
2. The maximum number of code-numbers assigned to VARIABLE-LIST for all REPORT-BLOCKS is 60.
3. Global variables are applicable to both the LOADS and HVAC subprograms. However, the HVAC subprogram does not use many of these variables (particularly the solar data), and unused fields will be blank.. To force the LOADS global variables to print, either include the global block with other LOADS blocks, or create an hourly-report with only a global block. In other words, do not include the global block with HVAC blocks.

SCHEDULE

DAY-SCHEDULE

WEEK-SCHEDULE

Describes schedules, which are hourly profiles of such quantities as lighting power, occupancy, and thermostat setpoint. The format of schedules is the same in LOADS, HVAC, and ECON input.

The SCHEDULE command references two related commands, DAY-SCHEDULE, which defines the hourly profile for a particular type of day (such as weekday, weekend day, or holiday), and WEEK-SCHEDULE, which defines what day schedules make up a weekly schedule. The following describes DAY-SCHEDULE and WEEK-SCHEDULE, then shows how and SCHEDULEs are built up from WEEK-SCHEDULEs and how WEEK-SCHEDULEs are built up from DAY SCHEDULEs.

Common Keywords

SCHEDULE, WEEK-SCHEDULE, and DAY-SCHEDULE share these two keywords:

TYPE

Accepts a code-word specifying the type of schedule. Various components that reference schedules are restricted to certain TYPEs. For example, lighting schedules use TYPE = FRACTION, fans use TYPE = ON/OFF, and thermostats use TYPE = TEMPERATURE.

Often more than one type is acceptable, but all types are never acceptable. For example, the SPACE:LIGHTING-SCHEDULE can be of TYPE = FRACTION or MULTIPLIER, but can never be of TYPE = TEMPERATURE.

The DAY-SCHEDULEs referenced by a WEEK-SCHEDULEs must be the same TYPE as specified for the WEEK-SCHEDULE. Similarly, the WEEK-SCHEDULEs referenced by a SCHEDULE must be of the same TYPE as specified for a SCHEDULE.

The available TYPEs are:

ON/OFF	accepts the binary values 0 and 1, where 0 means the schedule is OFF and 1 means the schedule is ON. Examples include schedules for fans and heating/cooling availability.
FRACTION	accepts values between and including 0.0 and 1.0. Examples include lighting, people, etc.
MULTIPLIER	accepts values 0.0 and above. Examples, include lighting, people, etc.
TEMPERATURE	accepts a value that represents a temperature. Examples include heating and cooling thermostat schedules.
RADIATION	accepts a value that represents a radiative flux, expressed in Btu/ft ² -hr or W/m ² . An example is the WINDOW:MAX-SOLAR-SCH.
ON/OFF/TEMP	accepts the binary values 0 and 1, similar to ON/OFF. Any other value is also acceptable, and is assumed to represent a flag temperature. When a temperature, the meaning of the value and its action varies by the component referencing the schedule.

For example, in the SYSTEM:HEATING-SCHEDULE, the binary values 0 and 1 disable and enable heating respectively. Any value other than 0 or 1 represents the outdoor drybulb temperature below which heating is enabled.

ON/OFF/FLAG

accepts the binary values 0 and 1, similar to ON/OFF. Any other value is also acceptable, and is assumed to represent a flag value. When a flag, the meaning of the value and its action varies by the keyword.

For example, in the SYSTEM:NATURAL-VENT-SCH, a value of 0 forces the windows closed, and a value of 1 allows windows to be open if the outdoor temperature is suitable, and a flag value of -1 allows windows to be open if the outdoor enthalpy is also suitable.

FRAC/DESIGN

accepts a value which is the fraction of the design quantity. Typical values range between 0.0 and 1.0. An entry of -999 causes the schedule to be ignored for that hour.

For example, in the SYSTEM:MIN-AIR-SCH, an entry of 0 or 1 will force the outdoor-air ratio to be 0% or 100% respectively. A value of -999 will cause the schedule to be ignored for the hour, and the outdoor-air ratio will be set by other calculations.

EXP-FRACTION

accepts a value between -1 and 1. An example is the WINDOW:SLAT-SCHEDULE.

FLAG

accepts a flag of any value. The flag value must exactly match a comparison criterion for the component to be active.

For example, in the ELEC-METER:COGEN-TRACK-SCH, a flag value of 1 means that cogeneration equipment should track the electric load, a value of 2 means track the thermal load, 3 means track the lesser of the electric or thermal load, etc.

RESET-TEMP

specifies that, rather than a 24-hour profile, that the DAY-SCHEDULE defines a relationship between the outside air temperature and a temperature setpoint, such as supply air temperature. Refer to the section below on “Reset Schedules” for more information.

RESET-RATIO

specifies that, rather than a 24-hour profile, that the DAY-SCHEDULE defines a relationship between the outside air temperature and a system control parameter, such as baseboard heating power. Refer to the section below on “Reset Schedules” for more information.

GROUP

This is a special, optional, keyword used by the PowerDOE graphical user interface. It has no application in the batch mode or other GUIs.

DAY-SCHEDULE

Defines the 24-hour profile for a single day. In its simplest form, the input for DAY-SCHEDULE is:

```
U-name = DAY-SCHEDULE
  TYPE = MULTIPLIER
  (all 24 hours covered) (values for each hour) ..
```

Example input:

```
LTG-1 = DAY-SCHEDULE
  TYPE           = FRACTION
  HOURS          = ( 1, 24)
  VALUES        = ( 0, 0, 0, 0, 0, 0, 0, 0,
                    0.3, 0.6, 0.8, 1, 1, 1, 1, 1,
                    1, 1, 0, 0, 0, 0, 0, 0)
  ..
```

Another way of expressing the same 24-hour profile is

```
LTG-1 = DAY-SCHEDULE
  TYPE           = FRACTION
  HOURS          = ( 1, 8)
  VALUES        = ( 0)
  HOURS          = ( 9, 11)
  VALUES        = ( 0.3, 0.6, 0.8)
  HOURS          = ( 12, 18)
  VALUES        = ( 1)
  HOURS          = ( 19, 24)
  VALUES        = ( 0)
  ..
```

The keywords HOURS and VALUES are optional, so the above input can be shortened to

```
LTG-1 = DAY-SCHEDULE
  TYPE           = FRACTION
                 ( 1, 8) (0)
                 ( 9, 11) (0.3, 0.6, 0.8)
                 ( 12, 18) (1)
                 ( 19, 24) (0) ..
```

Hour 1 is midnight to 1 am, hour 2 is 1 am to 2 am, etc. For example, (12,18) (1) (19,24) (0), above, means that the lights are fully on from 11 am to 6 pm and fully off from 6 pm to midnight.

If the above is the lighting schedule for midweek days, the following could be the lighting schedule for the weekend days:

```
LTG-2 = DAY-SCHEDULE
  TYPE           = FRACTION
                 ( 1, 24) (0) ..
```

Here, the value 0.0 is used for all 24 hours.

In these examples, TYPE=FRACTION indicates that the schedule value "multiplies" some quantity, such as lighting power. Other schedule types are possible, e.g. TYPE=TEMPERATURE, ON/OFF, etc.

HOURS

Is an optional keyword that accepts an integer range of hours corresponding to a list of values. Each range of hours must be entered in ascending order. As shown above, a range of hours may be specified with a set of values, without the need for the HOURS or VALUES keywords.

VALUES

Is an optional keyword that accepts a list of values corresponding to a range of hours. As shown above, a range of hours may be specified with a set of values, without the need for the HOURS or VALUES keywords.

If fewer VALUES are specified than correspond to the range of hours, the last value in the list will be used for all remaining hours in the range.

Rules

1. A U-name must appear before the DAY-SCHEDULE command.
2. The LIKE keyword may be used.
3. All 24 hours must be assigned values. The first hour specified must be 1, and the last hour must be 24. It is not possible to assign values past midnight (into the next day.)
4. All values within the HOURS and VALUES keywords must be enclosed in parenthesis.
5. A comma and/or one or more blanks must separate multiple values within parenthesis.
6. The keywords HOURS and VALUES may be omitted.
7. If two or more numbers are assigned to an HOURS keyword, the numbers must be in ascending numerical order.

DAY-SCHEDULE, Reset

When DAY-SCHEDULE:TYPE = RESET-TEMP or RESET-RATIO, the meaning of the day schedule is different. Rather than defining a 24-hour profile for a single day, the schedule defines a linear relationship between the outside air temperature and a system control parameter, such as a temperature setpoint or baseboard heating power. Different relationships for daytime and night time hours can be defined.

Example input:

```

DRS-1 = DAY-SCHEDULE
  TYPE = RESET-TEMP
        $ Daytime hours (5am to 5pm)
  DAY-HOURS = (6,17)
        $ Daytime reset relationship
  OUTSIDE-LO = 30
  OUTSIDE-HI = 60
  SUPPLY-HI-TEMP = 60
  SUPPLY-LO-TEMP = 0
        $ Night time reset relationship
  OUTSIDE-LO2 = 30
  OUTSIDE-HI2 = 60
  SUPPLY-HI-TEMP2 = 60
  SUPPLY-LO-TEMP2 = 60 ..
    
```

TYPE

Takes a code-word that specifies the type of reset relationship. This required keyword should be the first entered. Allowed values are:

RESET-TEMP	The reset relationship is between outside air temperature and supply air or supply water temperature. In this case the values of SUPPLY-LO, SUPPLY-LO2, SUPPLY-HI and SUPPLY-HI2 are temperatures.
RESET-RATIO	The reset relationship is between outside air temperature and heating output ratio (such as for baseboard heating). In this case the values of SUPPLY-LO, SUPPLY-LO2, SUPPLY-HI and SUPPLY-HI2 are ratios of heating output to maximum heating output.

DAY-HOURS

Accepts a list of two integer values that give the first and last hour of the day for which the daytime reset relationship is to be used. The default values for the first and last hours are 1 and 24, respectively. If the first and last hours are not 1 and 24, then the keywords OUTSIDE-HI2, OUTSIDE-LO2, SUPPLY-HI-TEMP2 (or SUPPLY-HI-RATIO2) and SUPPLY-LO-TEMP2 (or SUPPLY-LO-RATIO2) are required.

Daytime keywords

The following four keywords define the reset relationship during the daytime hours, i.e., during the hours specified by DAY-HOURS.

OUTSIDE-HI

Outside dry-bulb temperature that corresponds to SUPPLY-LO. OUTSIDE-HI should be greater than OUTSIDE-LO.

OUTSIDE-LO

Outside dry-bulb temperature that corresponds to SUPPLY-HI. OUTSIDE-LO should be less than OUTSIDE-HI.

SUPPLY-HI

The upper supply setpoint temperature (for TYPE = RESET-TEMP) or heating output ratio (for TYPE = RESET-RATIO) that corresponds to OUTSIDE-LO.

SUPPLY-LO

The lower supply setpoint temperature (for TYPE = RESET-TEMP) or heating output ratio (for TYPE = RESET-RATIO) that corresponds to OUTSIDE-HI.

Night time keywords

The following four keywords define the reset relationship during the night time hours, i.e., the hours outside the range specified by DAY-HOURS. These keywords are required when DAY-HOURS is not equal to (1,24).

OUTSIDE-HI2

Outside dry-bulb temperature that corresponds to SUPPLY-LO2. OUTSIDE-HI2 should be greater than OUTSIDE-LO2. Required when DAY-HOURS is not equal to (1,24).

OUTSIDE-LO2

Outside dry-bulb temperature that corresponds to SUPPLY-HI2. OUTSIDE-LO2 should be less than OUTSIDE-HI2. Required when DAY-HOURS is not equal to (1,24).

SUPPLY-HI2

The upper supply setpoint temperature (for TYPE = RESET-TEMP) or heating output ratio (for TYPE = RESET-RATIO) that corresponds to OUTSIDE-LO2. Required when DAY-HOURS is not equal to (1,24).

SUPPLY-LO2

The lower supply setpoint temperature (for TYPE = RESET-TEMP) or heating output ratio (for TYPE = RESET-RATIO) that corresponds to OUTSIDE-HI2. Required when DAY-HOURS is not equal to (1,24).

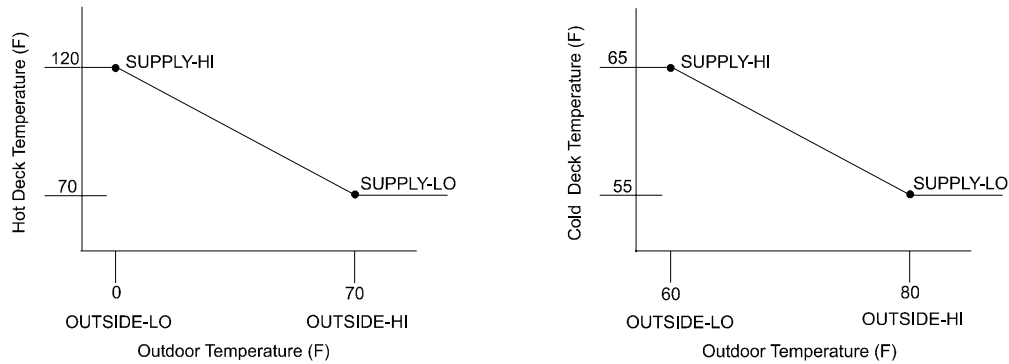

Figure 1 Typical DAY-RESET-SCH for deck temperature control

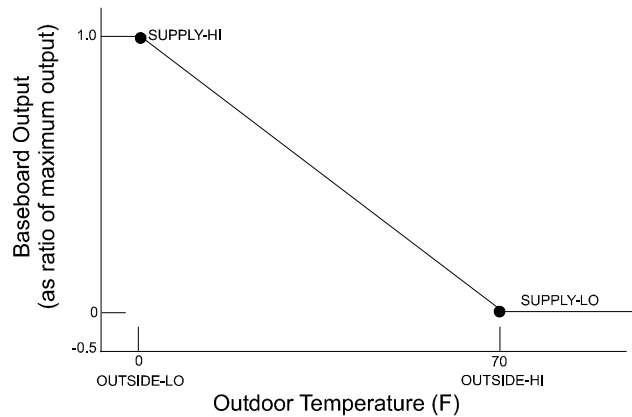

Figure 2 Typical DAY-RESET-SCH FOR baseboard control

A reset-type day schedule is incorporated into WEEK-SCHEDULEs and a SCHEDULE identically to other schedule types. Note, however, that a reset day-schedule cannot be “nested” into week schedules or schedules like other schedules. See the section below on “Nesting”.

WEEK-SCHEDULE

The week schedule command assigns DAY-SCHEDULEs to the days of the week, so that a week of schedule is built up. The form of the WEEK-SCHEDULE is:

U-NAME = WEEK-SCHEDULE
 (days of week covered) (U-name of DAY-SCHEDULE) .

Example input:

In the discussion above, we defined two DAY-SCHEDULEs -- LTG-1 represents week-days and LTG-2 represents week-ends and holidays. The following builds the day schedules up into a week schedule:

```
NORMAL = WEEK-SCHEDULE
  TYPE           = FRACTION
  DAYS           = ( MON , FRI )
  DAY-SCHEDULES = ( LTG-1 )
  DAYS           = ( SAT , HOL )
  DAY-SCHEDULES = ( LTG-2 )
  . .
```

where (MON,FRI) includes MON,TUE,WED,THU,FRI and (SAT,HOL) includes SAT,SUN,HOL. HDD and CDD represent the heating and cooling design days. The keywords HOURS and VALUES are optional, so the above input can be shortened to

```
NORMAL = WEEK-SCHEDULE
  TYPE           = FRACTION
                  ( MON , FRI ) LTG-1
                  ( SAT , HOL ) LTG-2  . .
```

Optionally, this can be shortened to:

```
NORMAL = WEEK-SCHEDULE
  TYPE           = FRACTION
                  ( WD ) LTG-1
                  ( WEH ) LTG-2  . .
```

where (WD) stands for week-days and (WEH) for week-ends and holidays. If Saturday is considered part of the normal week, you have to write (MON,SAT) (LTG-1) and (SUN,HOL) (LTG-2).

Day schedules for design days may also be specified as part of a week schedule. If LTG-DD is the schedule to be used on the design-days, then the above example can be expanded to:

```
NORMAL = WEEK-SCHEDULE
  TYPE           = FRACTION
                  ( MON , FRI ) LTG-1
                  ( SAT , HOL ) LTG-2
                  ( HDD )      LTG-3
                  ( CDD )      LTG-4  . .
```

DAYS

Is an optional keyword that accepts a code-word specifying the day corresponding to the following DAY-SCHEDULE. A range of days may be entered, corresponding to a set of DAY-SCHEDULEs. As shown above, a range of days may be specified with a day schedule, without the need for the DAYS or DAY-SCHEDULE keywords.

Acceptable code-words and their respective meanings are

MON,TUE,WED,THU,FRI Monday, Tuesday, Wednesday, Thursday, Friday

SAT, SUN, HOL Saturday, Sunday, Holiday

WD	Weekdays (Mon-Fri)
WEH	Weekends and holidays (Sat, Sun, Hol)
HDD, CDD	Heating design day, Cooling design day
ALL	All 10 days in the week schedule (Mon-Sun, Hol, HDD, CDD)

DAY-SCHEDULES

Is an optional keyword that accepts a list of U-names of DAY-SCHEDULEs corresponding to a range of days. As shown above, a range of days may be specified with a set of day-schedules, without the need for the HOURS or VALUES keywords.

If fewer day-schedules are specified than correspond to the range of days, the last schedule in the list will be used for all remaining days in the range.

If not specified, the Saturday schedule defaults to Monday’s, as do the design-day schedules. Sunday defaults to Saturday’s schedule.

Rules

1. A U-name must appear before the WEEK-SCHEDULE command.
2. The keywords DAYS and DAY-SCHEDULE may be omitted.
3. The list specified for DAYS may be either one element (such as MON.), or a two-element range (such as MON,THU). The days in a range must be in chronological order, where Monday is considered the first day of the week, and Holiday the last.
4. The referenced DAY-SCHEDULEs must be of the same TYPE as the WEEK-SCHEDULE.

SCHEDULE

The SCHEDULE command assigns particular WEEK-SCHEDULES to different times of the year.

In its simplest form, SCHEDULE takes the form:

```

U-NAME = SCHEDULE
      TYPE                = FRACTION
      THRU (calendar period covered) (U-name of WEEK-SCHEDULE)
      THRU (next calendar period )   (U-name of WEEK-SCHEDULE)
      ..
    
```

Example input:

To illustrate the purpose of SCHEDULE, assume we have a school that is closed in the summer and on week-ends and holidays. Therefore, we need another week type:

```

VACATION = WEEK-SCHEDULE
      TYPE                = FRACTION
                        (ALL) LTG-2 ..
    
```

where (ALL) stands for all days of the week, including holidays and design days, and LTG-2 was the DAY-SCHEDULE representing lights as being off for 24 hours.

To finalize the example:

```
LIGHTS = SCHEDULE
  TYPE           = FRACTION
  THRU JUN 10    NORMAL
  THRU SEP 5     VACATION
  THRU DEC 31    NORMAL ..
```

Rules

1. A U-name must appear before the SCHEDULE command.
2. Dates must be given in chronological order.
3. All schedules must extend at least through the end of the simulation period, as defined in the RUN-PERIOD.
4. The value entered as the day-of-the-month must be between 1 and the number of days in the month.
5. The code-word entered as the value of the month must be the first three letter of the name of the month (JAN, FEB, etc.)
6. Commas are optional. Spaces are equivalent to commas.
7. There is a maximum of 12 THRU's (or intervals) permitted in each schedule.
8. The LIKE keyword is not allowed.

Nesting of Schedules

Another option, nesting of schedules , can be very useful in lessening the chore of preparing schedules. In the above example we could have bypassed the WEEK-SCHEDULEs by nesting the DAY-SCHEDULEs in the SCHEDULE itself. For example:

```
LIGHTS = SCHEDULE
  TYPE           = MULTIPLIER
  THRU JUN 10    (WD) LTG-1 (WEH) LTG-2
  THRU SEP 5     (ALL) LTG-2
  THRU DEC 31    (WD) LTG-1 (WEH) LTG-2 ..
```

Note that reset schedules cannot be nested. That is, the following is not permitted:

```
RS-1 = SCHEDULE
  TYPE           = RESET-TEMP
  THRU DEC 31    (ALL)
  SUPPLY-HI      = 120
  SUPPLY-LO      = 70
  OUTSIDE-HI     = 70
  OUTSIDE-LO     = 0 ..
```

Use instead:

```
DSR-1 = DAY-RESET-SCH
  TYPE                = RESET-TEMP
  SUPPLY-HI           = 120
  SUPPLY-LO           = 70
  OUTSIDE-HI          = 70
  OUTSIDE-LO          = 0 ..

RS-1 =SCHEDULE
  TYPE                = RESET-TEMP
  THRU DEC 31         (ALL) DSR-1 ..
```

SCHEDULE-PD DAY-SCHEDULE-PD WEEK-SCHEDULE-PD

These commands are equivalent to SCHEDULE, DAY-SCHEDULE, and WEEK-SCHEDULE and may be used interchangeably. They are provided for the convenience of user-interfaces, such as eQUEST.

TYPE

Identical to TYPE in SCHEDULE

GROUP

Identical to GROUP in SCHEDULE

DAY-SCHEDULE-PD

Example Input

```
"Office Lites WD DSch" = DAY-SCHEDULE-PD
  TYPE                   = FRACTION
  VALUES                 = ( 0.05, 0.05, 0.05, 0.05, 0.05, 0.10,
                             0.10, 0.30, 0.90, 0.90, 0.90, 0.90,
                             0.80, 0.90, 0.90, 0.90, 0.90, 0.50,
                             0.30, 0.30, 0.20, 0.20, 0.10, 0.05 )
```

VALUES

Accepts a list of 24 entries corresponding to the 24 hours in a day.

You do not have to list all values in the day; all hours after the last hour specified will default to the last value entered. As a convenience, the following is equivalent to the above:

```
"Office Lites WD DSch" = DAY-SCHEDULE-PD
  TYPE                   = FRACTION
  VALUES                 = ( 0.05,   &D,   &D,   &D,   &D, 0.10,
                             &D, 0.30, 0.90,   &D,   &D,   &D,
                             0.80, 0.90,   &D,   &D,   &D, 0.50,
                             0.30,   &D, 0.20,   &D, 0.10, 0.05 )
```

Here, the value "&D" means to use the last previously defined hour's value for this hour's value.

WEEK-SCHEDULE-PD

Example Input

```
"Office Lighting WSch" = WEEK-SCHEDULE-PD
  TYPE                   = FRACTION
  DAY-SCHEDULES         = ( "Office Lites WD DSch",   $ Monday
                             "Office Lites WD DSch",   $ Tuesday
                             "Office Lites WD DSch",   $ Wednesday
                             "Office Lites WD DSch",   $ Thursday
                             "Office Lites WD DSch",   $ Friday
                             "Office Lites Sat DSch",   $ Saturday
                             "Office Lites Sun DSch",   $ Sunday
```

```
"Office Lites Sun DSch", $ Holiday
"Office Lites WD DSch", $ Heating DD
"Office Lites WD DSch" ) $ Cooling DD
```

..

DAY-SCHEDULES

Accepts a list of 10 DAY-SCHEDULE-PD entries corresponding to Monday-Sunday, a holiday, and the heating and cooling design days.

As a convenience, the following is equivalent to the above:

```
"Office Lighting WSch" = WEEK-SCHEDULE-PD
  TYPE = FRACTION
  DAY-SCHEDULES = ( "Office Lites WD DSch", $ Monday
                    &D, &D, &D, &D,
                    "Office Lites Sat DSch", $ Saturday
                    "Office Lites Sun DSch", $ Sunday
                    &D
                    "Office Lites WD DSch", $ Heating DD
                    "Office Lites WD DSch" ) $ Cooling DD
```

..

SCHEDULE-PD

Example Input

```
"SCE GS-2 Summer-Only Schedule" = SCHEDULE-PD
  TYPE = FLAG
  MONTH = ( 6, 9, 12 )
  DAY = ( 3, 30, 31 )
  WEEK-SCHEDULES = ( "Week Flag Value 0", $ Non-summer
                     "Week Flag Value 1", $ Summer
                     "Week Flag Value 0" ) $ Non-summer
```

MONTH

Accepts a list of integers specifying the ending months of the week schedules. The list must increase in numerical order

DAY

Accepts a list of integers specifying the ending days of the ending months of the week schedules. There must be a one-to-one correspondence of values in MONTH and DAY.

WEEK-SCHEDULES

Accepts a list of week schedules corresponding to the MONTHs and DAYs listed. The first week-schedule is used starting on January 1, through the first month and day listed. The second week schedule starts on the day immediately after the first set, and is active through the second month and day listed, etc.

DAY-SCHEDULE-PDs and WEEK-SCHEDULE-PDs cannot be nested into a SCHEDULE-PD.

RUN-PERIOD

The RUN-PERIOD command specifies the initial and final dates of the desired simulation period. As an alternative, you may use RUN-PERIOD-PD instead.

The initial date is the first date of the simulation, given in the form: month day year. The code-words that specify the names of the months are given below. The final date is the last simulation date, specified in the same manner as the initial date. U-name is not allowed.

The code-words for the months are:

JAN FEB MAR APR MAY JUN
JUL AUG SEP OCT NOV DEC

Example input: This instruction would run the program for one year:

```
RUN-PERIOD JAN 1 1979 THRU DEC 31 1979 ..
```

Rules

1. The initial and final dates specified in any one run must all be in the same year. The final date must be equal to or later than the initial date.
2. The day number cannot be greater than the number of days in the month associated with that date. For example, SEP 31 1978 is not valid.
3. The year of the RUN-PERIOD should ordinarily be the year of the data on the weather tape being used. The program and the weather file assume a 365 day year; for leap years, February 29 is ignored..

RUN-PERIOD-PD

This command is an alternative to RUN-PERIOD and is provided for the convenience of user interfaces such as eQUEST. Like RUN-PERIOD, this command specifies the initial and final dates of the desired simulation period. You may use either the RUN-PERIOD or the RUN-PERIOD-PD format in a batch mode input.

Example input:

```
"Entire Year" = RUN-PERIOD-PD
  BEGIN-MONTH      = 1
  BEGIN-DAY        = 1
  BEGIN-YEAR       = 1997
  END-MONTH        = 12
  END-DAY          = 31
  END-YEAR         = 1997
  ..
```

BEGIN-MONTH

Accepts an integer value specifying the beginning month, where 1 = January, 2 = February, etc.

BEGIN-DAY

Accepts an integer value specifying the beginning day.

BEGIN-YEAR

Accepts an integer value specifying the beginning year. 1998 is acceptable, 98 is not.

END-MONTH

Accepts an integer value specifying the ending month, where 1 = January, 2 = February, etc.

END-DAY

Accepts an integer value specifying the ending day.

END-YEAR

Accepts an integer value specifying the ending year. 1998 is acceptable, 98 is not.

Rules

1. The initial and final dates specified in any one run must all be in the same year. The final date must be equal to or later than the initial date.
2. The day number cannot be greater than the number of days in the month associated with that date. For example, SEP 31 1978 is not valid.
3. The year of the RUN-PERIOD should ordinarily be the year of the data on the weather tape being used. The program and the weather file assume a 365 day year; for leap years, February 29 is ignored.

SET-DEFAULT

The SET-DEFAULT instruction is used to assign a new default value to one or more keywords in a particular instruction.

The form of this instruction is

```
SET-DEFAULT FOR Command
      Keyword           = Value ..
```

where Command is the name of a command, Keyword is the name of a keyword in that command, and Value is the new default value to be assigned that keyword.

Example input:

```
SET-DEFAULT FOR WINDOW
      WIDTH             = 6.5
      HEIGHT           = 4
      GLASS-TYPE       = WEST-GLASS ..
```

This sets the width and height defaults for windows to 6.5 and 4.0, respectively, and the GLASS-TYPE to that defined in a GLASS-TYPE command with U-name WEST-GLASS.

Rules

1. Whenever a new default value is specified for a keyword, that value overrides the previous default value for that keyword, or creates a default value if the keyword did not have one originally.
2. The word FOR after SET-DEFAULT is required.
3. The sequence "Keyword = Value" may be repeated if the default for more than one keyword in a command is to be changed.
4. If the SET-DEFAULT is for a command that requires the TYPE keyword, the TYPE must be specified.

STOP

The STOP instruction indicates that the end of all input data has been reached.

The instruction takes the form

STOP . .

and directs the control processor to terminate data input and begin simulation, assuming COMPUTE instructions were entered and no fatal errors were detected.

The STOP instruction may be used only as a control instruction. Therefore, it may not occur between an INPUT instruction and an END instruction.

TITLE

The TITLE instruction is used to describe up to five lines of title information that are placed at the top of each summary, verification or hourly report.

The instruction takes the form

```
TITLE Line-N = *Literal* ..
```

where Line-N is one of five valid keywords (LINE-1, LINE-2, LINE-3, LINE-4, and LINE-5) and *Literal* is a series of up to 40 characters placed between two asterisks. The sequence Line-N = *Literal* may be repeated as necessary to define a complete title.

Title data are placed at the top of each report page in the following format:

```
line-1      line-2
line-3      line-4      line-5
```

Rules

1. The TITLE instruction may be used as a control instruction; it need not appear between an INPUT and END instruction sequence.
2. A literal value may not be continued on the following line.

Example input:

```
TITLE
LINE-1      = *ABC OFFICE BUILDING*
LINE-2      = *JONES AND SMITH ENGINEERING*
LINE-3      = *JERRY JONES - P.E.*      ..
```

The above instruction would cause

```
ABC OFFICE BUILDING      JONES AND SMITH ENGINEERING
JERRY JONES - P.E.
```

to appear at the top of all reports.

Envelope Components

This section describes the commands and keywords used for the heating and cooling loads calculations. Included here are the:

1. General building data – These include the location on the earth’s surface, orientation, design-day data, and simulation periods.
2. Floors – A floor is the fundamental element of the building’s geometry.
3. Spaces – A space defines the fundamental elements of a geometrically and thermodynamically distinct area on a floor
4. Walls – These enclose a space, and include the components for exterior-walls, roofs, interior-walls, and underground floors. Also included here are the more elemental components from which these components are created (materials, layers, and constructions).
5. Windows – These include the window command, as well as the more elemental components from which a window is built up (glass-layers, glass-types, etc.)
6. Lighting systems – Included here are lighting fixtures and lamps, usage profiles, and daylighting
7. People – This includes the number of people, activity levels, and occupancy profiles
8. Miscellaneous equipment – All other items which contribute to the heating and cooling loads.

BUILD-PARAMETERS

Specifies the orientation and other information about the building as a whole. The following example describes a building facing northwest/southeast. Heating peaks for system sizing will be determined from 6 a.m. to 6 p.m. Cooling peaks for system sizing will be determined from 8 a.m. to 5 p.m.

Example input:

```
BUILD-PARAMETERS
  AZIMUTH           = -45
  HEAT-PEAK-PERIOD = ( 7 , 18 )
  COOL-PEAK-PERIOD = ( 9 , 17 ) . .
```

AZIMUTH

Angle between true north and the y-axis of the building, expressed in degrees from 0 to 360(clockwise as seen from above) or 0 to -360(counter-clockwise as seen from above). Changing this angle has the effect of rotating the building about its z-axis (vertical axis). See Figure 3.

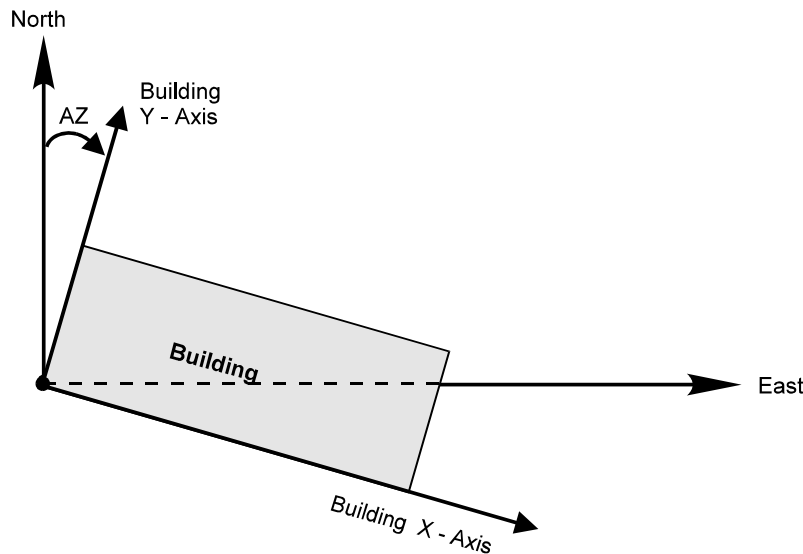

Figure 3 Positioning the building in the reference coordinate system

X-REF

Y-REF

Coordinates of the origin of the building coordinate system in the reference coordinate system (a coordinate system that is fixed to earth with origin set by the LATITUDE and LONGITUDE keywords (SITE-PARAMETERS command) and whose y-axis points north). You specify X-REF and Y-REF only if (1) you want to study the thermal effects of moving (rotating or translating) your building, and (2) there are shading surfaces, such as neighboring buildings, that are "fixed", i.e., do not move when you move your building. In this case, your building must be positioned using X-REF and Y-REF.

Figure 4 shows an example in which a fixed shade and an L-shaped building have been positioned in the reference coordinate system using X-REF, Y-REF, and AZIMUTH for the building and X-REF, Y-REF for a fixed shade (see FIXED-SHADE command). Figure 4 also shows the building being translated and rotated (dashed lines) in the

reference coordinate system by changing the building's X-REF, Y-REF, and AZIMUTH values. This moves the building but not the fixed shade.

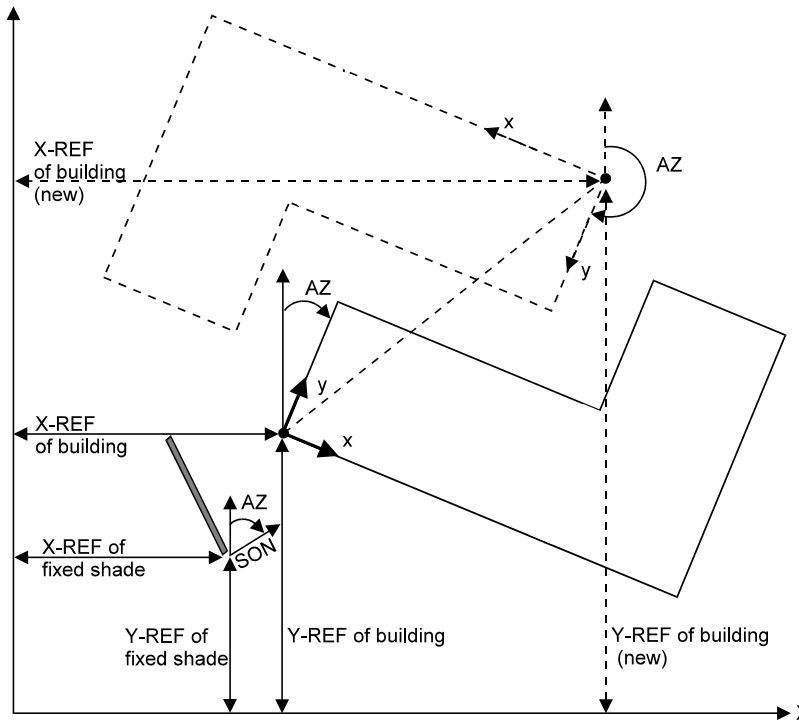

Figure 4 Positioning a building and fixed-shade in the reference coordinate system

GROSS-AREA

Gross floor area (outside dimensions) of all spaces in the building. This keyword is used only for the BEPS (Building Energy Performance Summary) Report in HVAC, which gives annual building energy use per unit gross floor area. Defaults to the net area, which is the sum of the area of all conditioned spaces.

HEAT-PEAK-PERIOD

Specifies those hours in a day during which hourly peak heating loads for system sizing will be calculated. Allows you to have the program ignore peaks that occur when the building is unoccupied. The input is a list of two values (minimum hour and maximum hour). Between and including these two hour values, hourly heating peaks will be calculated. For example, HEAT-PEAK-PERIOD=(9,18) causes the heating peak to be calculated between 8 a.m. (the beginning of hour 9) and 6 p.m. (the end of hour 18). Minimum hour must be less than maximum hour. The default is (1,24), which means that hourly peaks will be calculated for all day and all night. If SYSTEMS is permitted to size the secondary HVAC equipment, it will use the peaks found within the stated hours.

COOL-PEAK-PERIOD

Same as HEAT-PEAK-PERIOD, except applies to hours during which peak cooling will be calculated.

HOLIDAYS

Takes the U-name of a HOLIDAYS command that indicates which days of the year are to be considered holidays in Schedules. See "HOLIDAYS Command" and "DAY-SCHEDULE Command."

FUNCTION

Causes an Input Function to be calculated in LOADS subroutine DAYCLS. See "Input Functions" in the *DOE-2.2 Topics*.

DAYL-FUNCTION

Causes an Input Function to be calculated in LOADS subroutine DEXTIL that allows you to modify the program's regular calculation of exterior horizontal illuminance for the daylighting simulation. See "Input Functions" in the *DOE-2.2 Topics*.

BUILDING-SHADE

Specifies the position, size, orientation and transmittance of surfaces that cast shadows on the exterior walls and roofs of a building. Examples are trees, hills, or an adjacent building overhangs. LIKE may be used to copy a previously defined BUILDING-SHADE. Both the direct (from the sun itself) and diffuse (from the sky and ground) components of solar radiation are shaded by BUILDING-SHADEs. However, the program does not account for reflection of solar radiation from BUILDING-SHADEs onto the building. See "Building Shades" in the *DOE-2.2 Topics*.

In addition to BUILDING-SHADE, there are three other methods of specifying shades:

1. Using the FIXED-SHADE command to specify shading surfaces that are fixed with respect to the earth, and do not move when the building is translated or rotated.
2. Entering SHADING-SURFACE = YES in the EXTERIOR-WALL command. This lets that wall shade other walls, such as in an L-shaped building.
3. Using the overhang and fin keywords under WINDOW and DOOR.
4. Specifying the SETBACK under WINDOW and DOOR.

Example input:

The following example places a shading surface near the building (see Figure 5). A horizontal shading surface (the roof of a carport) is located parallel to and 10 feet south of the building with its west edge aligned with the building's west side. The shading surface is 20 by 15 (long dimension is parallel to the building) and is 10 feet above the ground.

```
CARPORT = BUILDING-SHADE
HEIGHT           = 15
WIDTH            = 20
TRANSMITTANCE    = 0                               $the default$
X                = 0
Y                = -25
Z                = 10
AZIMUTH          = 180
TILT             = 0  . .
```

Because X, Y, Z, AZIMUTH, and TILT of a BUILDING-SHADE are defined in the building coordinate system, a rotation of the building (accomplished by changing AZIMUTH in the BUILD-PARAMETERS command) will carry all BUILDING-SHADEs along with the building, even those that are detached, such as adjacent buildings and trees. If you do not want shades to move with the building when it is rotated, use the FIXED-SHADE command instead of BUILDING-SHADE.

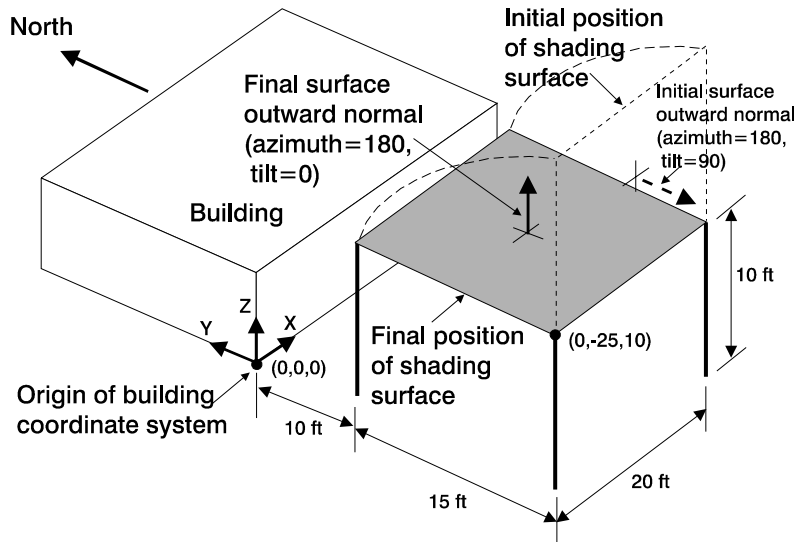

Figure 5 Positioning a shading surface in the building coordinate system

HEIGHT

Height of the shading surface (dimension along the Y-axis of the shade's local coordinate system)

WIDTH

Width of the shading surface(dimension along the X-axis of the shade's local coordinate system).

**X
Y
Z**

X, Y, and Z give the position of the lower left hand corner (when looking into the surface outward normal) in the building coordinate system. In Figure 5, X=0, Y=-25, and Z=10.

AZIMUTH

Angle between the y-axis of the building coordinate system and the projection of the shading surface outward normal onto the horizontal plane. To determine the azimuth for a horizontal shading surface, use the following procedure (see Figure 5):

1. Choose the origin (lower left hand corner) of the shading surface.
2. Mentally rotate the surface to a vertical position without moving the origin.
3. Determine the angle between the building y-axis and the surface outward normal (which will now be horizontal).
4. Mentally rotate the surface back to horizontal.

TILT

Angle between the z-axis of the building coordinate system (vertical) and the surface outward normal.

TRANSMITTANCE

Fraction of incident solar radiation that is transmitted by the shading surface. The default value is 0.0, which means the surface is opaque. A value greater than 0.0 represents a device that passes some solar radiation, such as a tree, lattice, or fabric. Using SHADE-SCHEDULE allows seasonal variation in transmittance. Daylighting calculation assumes TRANSMITTANCE = 0.

SHADE-SCHEDULE

Takes the U-name of a schedule of TYPE=MULTIPLIER that gives the time-dependent transmittance of the shading device for direct (beam) solar radiation. The values in the schedule override the TRANSMITTANCE value. The range of the schedule values is 0.0 to 1.0. Used only to simulate variable exterior shading devices. The program calculates direct solar shading factors for sun positions on the first day of each month, so only the SHADE-SCHEDULE values on those particular days are used. Also, the program calculates diffuse solar shading factors only once (before the hourly loads calculation); this means that SHADE-SCHEDULE has no effect on diffuse shading and the TRANSMITTANCE value is used instead. SHADE-SCHEDULE is not used in the daylighting calculation, which assumes building shades have zero transmittance at all times.

SHADE-VIS-REFL

Visible reflectance of that side of a BUILDING-SHADE from which the outward normal points. The other side of the shading surface is assumed to be black, i.e., to have zero reflectance. Used only for daylighting calculation. See "Daylighting" in the *DOE-2.2 Topics*.

SHADE-GND-REFL

Visible reflectance of the ground in the vicinity of the BUILDING-SHADE. Used only for daylighting calculation. See "Daylighting" in the *DOE-2.2 Topics*.

CONSTRUCTION

Specifies the construction characteristics and properties of an exterior wall, exterior floor, roof, interior wall, interior floor, ceiling, underground wall, underground floor, or non-glass door. U-name must be used so that the CONSTRUCTION may be referenced in a subsequent EXTERIOR-WALL, ROOF, INTERIOR-WALL, UNDERGROUND-WALL, UNDERGROUND-FLOOR, or DOOR command. LIKE may be used to copy a similar CONSTRUCTION.

Example inputs:

1. An exterior wall is constructed of heavy-weight concrete block with stucco exterior. Here, CBLOCK is the U-name of a previously defined LAYERS instruction, or a LAYERS in the library (see "LAYERS Command").

```
HEAVY = CONSTRUCTION
  TYPE           = LAYERS
  LAYERS         = CBLOCK
  ABSORPTANCE    = 0.65
  ROUGHNESS      = 1 ..
```

2. An interior wall is light wood framing with drywall finish.

```
LIGHT = CONSTRUCTION
  TYPE           = U-VALUE
  U-VALUE        = 0.306 ..
```

3. Concrete with interior insulation from the Library.

```
WALL-1 = CONSTRUCTION
  LAYERS         = "ASH Wall-74 lay"
  ABSORPTANCE    = 0.88
  ROUGHNESS      = 2 ..
```

TYPE

Specifies the type of construction.

LAYERS	Indicates that the LAYERS keyword will be used to specify a layered construction. The program will calculate response factors for this construction. The response factors will be used in the hourly simulation to calculate the dynamic, time-delayed heat flow through the construction. Recommended for all but lightweight (low heat capacity) constructions.
U-VALUE	Indicates that the U-VALUE keyword will be used to specify the conductance of the construction. In this case, the heat flow through the construction will be considered to be instantaneous, i.e., without time delay. Recommended only for lightweight (low heat capacity) constructions.

LAYERS

Required when TYPE=LAYERS. Takes the U-name of a previously defined LAYERS instruction or a layers code-word from the Library ("Construction Library" in the *DOE-2.2 Libraries & Reports*).

U-VALUE

Required when TYPE=U-VALUE. For exterior surfaces, equals the overall conductance of the surface including the inside air film but excluding the outside air film. For INTERIOR-WALLS, includes the air film on both sides of

the wall. For UNDERGROUND-WALLS and UNDERGROUND-FLOORS, includes the inside air film. Table 1 shows typical U-Values for some lightweight walls.

Table 1 Example U-Values for Lightweight Construction

Construction	U-value	
	Btu/h-ft ² -F	W/m ² -K
Exterior Walls (includes inside surface air film)		
Wood sheathing, 1/2" on studs, 1/2" gypsum board	0.35	1.99
Metal siding on 1/2" plywood studs, 1/2" gypsum board	0.38	2.16
Stucco on 3/4" pine studs, 1/2" gypsum board	0.34	1.93
Roofs (includes inside surface air film)		
Wood shingles on 1/2" plywood, 2"x8" studs, 1/2" gypsum board	0.28	1.59
Built-up roof on plywood deck, 2"x8" studs, 1/2" gypsum board with acoustical tile	0.27	1.53
Interior Walls and Floors (includes air film on both sides)		
Gypsum board, 1/2", on either side of metal studs	0.32	1.82
Hardwood floor on 1/2" deck, 2" x 8" floor joists, subfloor, tile (ceiling to space below)	0.20	1.13

Doors are also defined as a CONSTRUCTION with TYPE=U-VALUE. Table 2 gives some typical U-values for doors.

Table 2 Example U-Values for Lightweight Construction
U-values shown in Btu/h-ft²-F and, in parentheses, W/m²-K

	No Storm Door	Storm Door with Wood	Storm Door with Metal
Solid Wood Door			
1.0 in (2.5 cm)	0.64 (3.63)	0.30 (1.70)	0.39 (2.21)
1.25 in (3.2 cm)	0.55 (3.12)	0.28 (1.59)	0.34 (1.93)
1.5 in (3.8 cm)	0.49 (2.78)	0.27 (1.53)	0.33 (1.87)
2.0 in (5.1 cm)	0.43 (2.44)	0.24 (1.36)	0.29 (1.65)
Steel Door [1.75 in (4.4 cm) thick]			
Mineral fiber core	0.59 (3.35)		
Urethane core	0.19 (1.08)		
Polystyrene core	0.47 (2.67)		

ABSORPTANCE

Specifies the solar radiation absorptance of an exterior surface of an EXTERIOR-WALL or ROOF. This keyword is not appropriate for INTERIOR-WALL, UNDERGROUND-WALL, or UNDERGROUND-FLOOR. Typical ABSORPTANCE values are given in Table 3.

Table 3 Solar Absorptance of Exterior Surfaces*

Material	Absorptance	Paint	Absorptance
Aluminum, polished refl sheet	0.12	Aluminum paint	0.40
Asphalt pavement, weathered	0.82	Black, flat	0.95
Brick, buff, light	0.55	Black, lacquer	0.92
Brick, red	0.88	Black, oil	0.90
Brick, Stafford blue	0.89	Black, optical flat	0.98
Brick, white glazed	0.25	Blue, azure lacquer	0.88
Cement, uncolored asbestos	0.75	Blue, dark	0.91
Cement, white asbestos	0.61	Blue, medium	0.51
Concrete, black	0.91	Blue-gray, dark	0.88
Concrete, brown	0.85	Brown, dark brown	0.88
Concrete, uncolored	0.65	Brown lacquer	0.79
Film, Mylar aluminized	0.10	Brown, medium	0.84
Felt, bituminous	0.88	Brown, medium light	0.80
Felt, bituminous, aluminized	0.40	Gray, dark	0.91
Gravel	0.29	Gray, light oil	0.75
Iron, white-on-galvanized	0.26	Green, lacquer	0.79
Lab vapor deposited coatings	0.02	Green, lacquer, dark	0.88
Marble, white	0.58	Green, light	0.47
Roof, white built-up	0.50	Green, medium dull	0.59
Roofing, green	0.86	Green, medium Kelly	0.51
Slate, blue-gray	0.87	Olive, dark drab	0.89
Tin surface	0.05	Orange, medium	0.58
Wood, smooth	0.78	Red, oil	0.74
		Rust, medium	0.78
		Silver	0.25
		White, gloss	0.25
		White, lacquer	0.21
		White, semi-gloss	0.30
		Yellow	0.57

*Compilation of data from several sources including "Passive Solar Design Analysis" by J.D. Balcomb (DOE, Office of the Assistant Secretary for Conservation and Solar Energy, December 1979).

ROUGHNESS

Takes a code-number that indicates the relative roughness of the exterior surface finish of an EXTERIOR-WALL or ROOF. This keyword is not appropriate for INTERIOR-WALL, UNDERGROUND-WALL, or UNDERGROUND-FLOOR. The code-numbers are given in Table 4.

Table 4 Roughness Codes

Wall Finish	Roof Finish	Code number
Stucco	Wood shingles or built-up roof with stones	1
Brick or Plaster		2
Concrete (poured)	Asphalt shingles	3 (default)
Clear pine		4
Smooth plaster	Metal	5
Glass or Paint on Pine		6

WALL-PARAMETERS

Takes the U-name of a previously-defined WALL-PARAMETERS command that is used to assign certain values for Trombe walls and sunspace interior walls. See WALL-PARAMETERS command and TROMBE-WALL-NV command. See also "Sunspaces" in the *DOE-2.2 Topics*.

DESIGN-DAY

Specifies design weather data for sizing heating and cooling equipment. Two separate design days may be input, one for heating and one for cooling. The program determines design peak loads by simulating the building for a 24-hour period¹ on each of the design days. The design peak loads are used by the HVAC subprogram to size primary and secondary heating and cooling equipment. See "Design Days" in the *DOE-2.2 Topics*.

You may specify schedules for the design days that are different from the schedules in the regular run period simulation. In this way you can be as conservative as desired by, for example, scheduling zero occupancy and lights on the heating design day and maximum occupancy and lights on the cooling design day. This is done by using the CDD (cooling design day) and HDD (heating design day) day types in the WEEK-SCHEDULE command. If you do not include these day types in your schedules, the program will use the schedule values corresponding to the MON (Monday) day type for the design day calculations.

If either the heating or cooling design day is not specified, the program will determine the corresponding design heating or cooling loads using weather file data.

A good source of design day data for cities in the U.S., Canada, and other countries is the "Weather Data" chapter of the ASHRAE Handbook of Fundamentals.

Example input:

The following are possible design days (in English units) for Chicago (based on 2.5% design days for Chicago O'Hare in Chapter 24, "Weather Data", 1989 ASHRAE Handbook of Fundamentals):

CHICAGO-HDD = DESIGN-DAY

TYPE	=	HEATING
DRYBULB-HIGH	=	-4
HOUR-HIGH	=	15
HOUR-LO	=	7
WIND-DIR	=	WNN
WIND-SPEED	=	9
CLOUD-AMOUNT	=	5
GROUND-T	=	46 ..

CHICAGO-CDD = DESIGN-DAY

TYPE	=	COOLING
DRYBULB-HIGH	=	89
DRYBULB-RANGE	=	20
WETBULB-AT-HIGH	=	74
HOUR-HIGH	=	15
HOUR-LO	=	7
WIND-DIR	=	SW
WIND-SPEED	=	6.5 \$7.5 MPH\$
CLOUD-AMOUNT	=	0
GROUND-T	=	61 ..

TYPE

Takes a code-word that specifies whether this is a heating or cooling design day.

HEATING Specifies a heating design day.

COOLING Specifies a cooling design day.

MONTH

Month in which the design day occurs. The default is 1 (i.e., January) for TYPE=HEATING and 6 (i.e., June) for TYPE=COOLING.

DAY

Day of the month the design day occurs.

NUMBER-OF-DAYS

Accepts an integer greater from 1 to 365; the default is 1. This value represents the number of days for which the DESIGN-DAY weather conditions are simulated. For each of the days of simulation the solar position is calculated, however, the daily weather variables and design day schedule values are kept constant.

This feature allows you to have the design day weather conditions simulated for a period of time during which the solar conditions (the position of the sun in the sky) is changing. The schedules used for each design day run, however, are held constant based upon the TYPE of the design day. For HEATING design days the simulation is performed using the HDD day type in each WEEK-SCHEDULE; HDD is the 9th entry of the DAY-SCHEDULE list and its value defaults to the DAY-SCHEDULE specified for Monday.) For COOLING design days the simulation is performed using the CDD day type in each WEEK-SCHEDULE; CDD is the 10th entry of the DAY-SCHEDULE list and its value defaults to the DAY-SCHEDULE specified for Monday.)

CLOUD-AMOUNT

Cloud cover expressed on a scale from 1 to 10, where 0=clear and 10=completely overcast. This cloud amount is used for the entire day.

HOURLY-HIGH

Hour the day that DRY-BULB-HI occurs (1=midnight to 1 a.m., 2=1 a.m. to 2 a.m., etc.).

HOURLY-LOW

Hour the day that DRY-BULB-LO occurs (1=midnight to 1 a.m., 2=1 a.m. to 2 a.m., etc.).

DRYBULB-HIGH

Maximum outdoor dry-bulb temperature on the design day. This is a required keyword..

DRYBULB-RANGE

Difference between DRYBULB-HIGH and the minimum outside dry-bulb temperature. Note that the value 0.0 gives a constant dry-bulb temperature equal to DRYBULB-HIGH for the whole day.

WETBULB-AT-HIGH

Outside wet-bulb temperature when DRYBULB-HIGH occurs. Required for TYPE=COOLING. If not specified for TYPE=HEATING, program assumes that the outside relative humidity is 50 percent for the entire heating design day.

WIND-DIR

Takes a code-word indicating the wind-direction. N=north, NNE=north-northeast, NE=northeast, etc.

WIND-SPEED

Local wind speed. The heating default corresponds to 15 mph, the cooling to 7.5 mph.

GROUND-T

Average ground temperature for the specified MONTH. Default value is taken from the weather file. If the building has underground surfaces (entered with the UNDERGROUND-FLOOR or UNDERGROUND-WALL

commands), GROUND-T should not be entered since the underground surface heat transfer algorithm assumes that ground temperatures from the weather file will be used.

DOOR

This instruction is used to specify the size of a door and its heat-transfer characteristics. Each DOOR instruction applies to the EXTERIOR-WALL instruction preceding it and describes a door on that exterior wall. Glass doors should be treated as windows rather than doors. Overhangs and fins can be applied to doors in the same way as described under the WINDOW command. U-name may be specified. LIKE may be used to copy data from a previously entered and U-named DOOR instruction.

Example input:

```
D1 = CONSTRUCTION
    TYPE                = U-VALUE
    U-VALUE              = 0.5 ..

DOOR1 = DOOR
    HEIGHT              = 7
    WIDTH               = 3
    CONSTRUCTION        = D1 ..
```

MULTIPLIER

Specifies the number of identical doors on the wall.

HEIGHT

Door height. Height times width must not be greater than the area of the parent wall.

WIDTH

Door width. Height times width must not be greater than the area of the parent wall.

X

Y

X and Y are the coordinates of the lower left-hand corner of the door in the coordinate system of the parent wall. If X is not specified, the program will center the door horizontally on the wall. If Y is not specified, the door will be centered vertically.

CONSTRUCTION

Takes the U-name of a previously defined or library CONSTRUCTION that specifies the U-value of the door. This is a required keyword.

INF-COEF

Specifies an infiltration flow coefficient used to compute the infiltration resulting from cracks around the door and its frame. Used only if INF-METHOD = CRACK in SPACE or SPACE CONDITIONS. The program calculates the door infiltration rate as

$$\text{Infil} = \text{INF-COEF} * dP^{1/2} * L$$

where

Infil	infiltration airflow (cfm)
P	inside-outside air pressure difference (inches of water)
L	door perimeter (ft)

This keyword should not be used with INPUT-UNITS=METRIC. Typical values of INF-COEF are given in Table 5.

Table 5 Door Infiltration Coefficients

Door Configuration	INF-COEF	Door Configuration	INF-COEF
Residential (3-ft x 7-ft.)		Office (3.5ft x 7-ft.)	
closed with weather stripping	2.4	door closed	3.1
average use with weather stripping	9.8	door and vestibule open 10 % of time	9.3
average use without weather stripping	12.0	door open 10 percent of time	13.5
		door open 25 percent of time	55.0
Garage or Shipping Room		door open 50 percent of time	153.0
No use	6.0		
Average use	60.0	Revolving, average use	12.0

SHADING-DIVISION

Integer value that specifies the number of strips the door is divided into for shading calculations. A high number of shading divisions gives a more accurate shading calculation but requires more computer time. If the estimated effect of the shading on the overall building load is large, use more (20 to 40) divisions. If the estimated effect of the shading on the overall building load is small, use fewer (1-10) divisions.

SKY-FORM-FACTOR

The fraction of the hemisphere seen by the door that is subtended by the sky. Either both SKY-FORM-FACTOR and GND-FORM-FACTOR or neither of these should be specified. In most cases it is recommended that you do not specify these keywords since the program will calculate them. Used by the program to calculate diffuse solar shading and sky and ground IR radiation shading.

GND-FORM-FACTOR

The fraction of the hemisphere facing the door that is subtended by the ground, adjacent buildings, trees, etc. Either both SKY-FORM-FACTOR and GND-FORM-FACTOR or neither of these should be specified. In most cases, it is better not to specify these keywords since the program will automatically calculate them. Used to calculate diffuse solar shading and sky and ground IR radiation shading.

SETBACK

Distance that the door is recessed from the outside surface of the parent wall. A setback casts a shadow on the door, which the program calculates

FUNCTION

Invokes a function calculation for the door. See the "Input Functions" section in the *DOE-2.2 Topics*.

Fins and Overhangs

The following keywords describe overhangs and fins that shade the door. For definitions, see the WINDOW command, which uses the same keywords.

OVERHANG-A
OVERHANG-B
OVERHANG-W
OVERHANG-D
OVERHANG-ANGLE
LEFT-FIN-A
LEFT-FIN-B
LEFT-FIN-H
LEFT-FIN-D
RIGHT-FIN-A
RIGHT-FIN-B
RIGHT-FIN-H
RIGHT-FIN-D

Notes

1. For overhang shading calculations to be performed, both OVERHANG-W and OVERHANG-D must be specified. If either of them is specified, but not both, a warning message is printed and overhang shading is not performed.
2. For fin shading calculations to be performed, the pair, LEFT-FIN-H and LEFT-FIN-D or RIGHT-FIN-H and RIGHT-FIN-D, must be specified. If one of the pair is specified, but not both, a warning message is printed and fin shading is not performed.
3. Even though overhangs and/or fins are specified under the DOOR command, these shading surfaces are attached to the wall where the door is located and thus shade both the door and the wall. Also, if this DOOR is referred to in another DOOR command with the LIKE keyword, the attached shades are also copied.

EXTERIOR-WALL OR ROOF

Specifies the size and construction of an exterior surface of a space such as an exterior wall, roof, or exterior floor. EXTERIOR-WALL and ROOF are synonymous except that the default TILT for EXTERIOR-WALL is 90°, and for ROOF is 0°. Each EXTERIOR-WALL or ROOF applies to the SPACE instruction preceding it and describes one of the exterior surfaces of that space.

Example input:

```

SP-1 = SPACE
    . . .

FRONT-1 = EXTERIOR-WALL
    HEIGHT           = 8
    WIDTH            = 100
    AZIMUTH          = 180
    CONSTRUCTION     = WALL-1 . .

```

CONSTRUCTION

Takes the U-name of a previously-defined or library CONSTRUCTION instruction. This is a required keyword. See CONSTRUCTION command.

LOCATION

If the wall is in a SPACE with SHAPE=BOX, then TOP, BOTTOM, LEFT, RIGHT, FRONT, or BACK is used to indicate on which face of the box the wall is located. From this, and the SPACE keywords HEIGHT, WIDTH and DEPTH, the program determines the wall's values of X, Y, Z, HEIGHT, WIDTH, AZIMUTH and TILT.

If the wall is in a SPACE with SHAPE=POLYGON, then LOCATION=SPACE-V1, SPACE-V2, etc. is used to determine the wall's values of X, Y, Z, HEIGHT, WIDTH, AZIMUTH and TILT. For example, LOCATION=SPACE-V1 means that the lower left hand corner of the wall is located at the vertex 1 of the SPACE POLYGON. The program then positions the wall so that it is vertical (TILT=90°) and its x-axis passes through vertex 1 and vertex 2 of the SPACE POLYGON (which determine the wall's AZIMUTH). The wall HEIGHT is set to HEIGHT of the SPACE (which defaults to the SPACE-HEIGHT for the FLOOR) and the wall WIDTH is set to the distance between vertex 1 and vertex 2. A similar procedure is followed for LOCATION=SPACE-V2, SPACE-V3, etc.

If LOCATION=TOP, the wall is positioned as a ceiling of the SPACE, with a shape that is the same as the SPACE's POLYGON. If LOCATION=BOTTOM, the wall is positioned as a floor of the SPACE, with a shape that is the same as the mirror image of the SPACE's POLYGON (a mirror image polygon is automatically created). For Spaces using square or rectangular POLYGONS, then LOCATION=TOP, BOTTOM, LEFT, RIGHT, FRONT, or BACK can be used as described above for spaces having SHAPE=BOX.

POLYGON

Takes the U-name of a previously-defined POLYGON command. This keyword is used in place of HEIGHT and WIDTH to describe non-rectangular walls. See the POLYGON Command.

HEIGHT

Height of the wall; dimension of the exterior wall parallel to the y-axis in the surface coordinate system. This is a required keyword unless POLYGON or LOCATION is used.

WIDTH

Width of the wall; dimension of the exterior wall parallel to the x-axis in the surface coordinate system. This is a required keyword unless POLYGON or LOCATION is used.

AZIMUTH

Clockwise angle between the parent space's Y-axis and the horizontal projection of the wall's outward; normal (Figure 6). For example, if the Y-axis of the parent space points north, then a north-facing wall has AZIMUTH=0, an east-facing wall has AXIMUTH=90, a south-facing wall has AZIMUTH=180, etc. If LOCATION or POLYGON is used, this value defaults to the appropriate value.

TILT

Angle between vertical and the surface outward normal (Figure 6). For EXTERIOR-WALL, the default is 90((vertical surface). For ROOF, the default is 0((upward-facing horizontal surface). A downward-facing exterior surface has TILT=180(.

X

Y

Z

X, Y, and Z are the coordinates of the lower left-hand corner of the wall (Figure 6), (as viewed from the outside) in the space coordinate system. If LOCATION or POLYGON is used, these values default to the appropriate value.

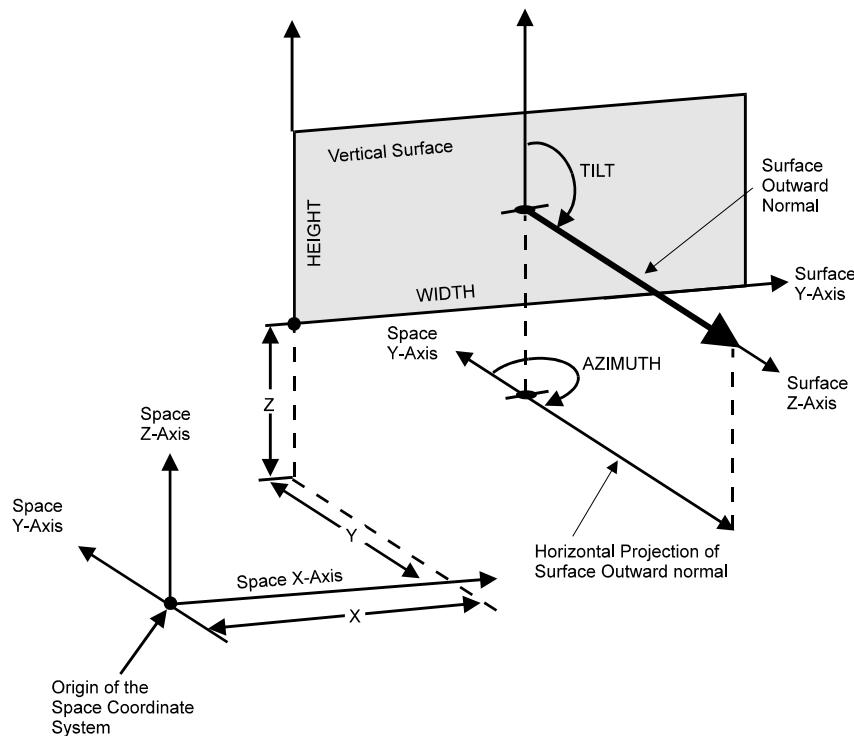

Figure 6 Positioning a wall in the space coordinate system

DEG-FROM-NORTH

This keyword allows expressions for exterior surfaces (walls, roofs, and windows) to be constructed to allow the assignment of component construction based upon the facing of the surface; it has no other purpose.

The value of this keyword defaults to the azimuth in degrees, measured clockwise from true north, of this wall. The default takes into account the building, floor, space and wall azimuths. The value is in the range from 0.0 to 359.99. The calculation of this default requires that the SITE-PARAMETERS and BUILDING-PARAMETERS commands be input prior to any EXTERIOR-WALL or ROOF command.

MULTIPLIER

Specifies the number of identical exterior surfaces located in the same plane. MULTIPLIER multiplies the net area of the surface (surface area minus window area minus door area). It also multiplies any WINDOW and DOOR area associated with this surface.

GND-REFLECTANCE

Defines the solar reflectance of the ground in the vicinity of the EXTERIOR-WALL.

Table 6 Typical Ground Reflectance Values

Surface	GND-REFLECTANCE
Asphalt (Paved)	0.18
Concrete (Bituminous)	0.10
Concrete (Light-Colored)	0.32
Concrete (Old)	0.22
Field (Green)	0.12 - 0.25
Field (Wheat)	0.07
Grass (Dry)	0.24
Ocean	0.05
Rock (Crushed) Surface	0.20
Soil (Dark)	0.08

SOLAR-FRACTION

The fraction of the solar radiation entering a space that is absorbed by this exterior wall. Used by the program to calculate custom weighting factors for solar heat gain (see "Weighting Factors" in the *DOE-2.2 Topics*). For exterior walls containing windows, SOLAR-FRACTION applies to the opaque part of the wall. For exterior walls containing doors, the program automatically apportions the SOLAR-FRACTION between wall and door according to their relative areas. A caution message will be issued if the sum of the SOLAR-FRACTIONS for a given space is not within 10 percent of 1.0, and the program will adjust the SOLAR-FRACTIONS so that their sum is 1.0. The program multiplies each SOLAR-FRACTION by a factor that accounts for the amount of incoming solar radiation that is reflected back out of the space through the glazing.

If all SOLAR-FRACTIONS for a space are allowed to default, the program will assume that 60 percent of the incoming solar radiation is absorbed by the floor; the remaining 40 percent will be distributed to the other surfaces (excluding windows), according to their surface areas. If there is no floor, the full 100 percent will be distributed to the surfaces (excluding windows), according to their surface areas.

To override this default procedure, you can explicitly specify SOLAR-FRACTION values for all the surfaces or for some of the surfaces. If not all of the SOLAR-FRACTIONS are input, the program will sum the values specified and distribute the balance (up to 1.0) to the other surfaces. Thus, if you specify SOLAR-FRACTION = 0.7 for the floor only, the program will distribute the remaining 0.3 to the walls and ceiling, according to their area and INSIDE-SOL-ABS value.

The distribution of absorbed solar radiation depends on the space geometry and surface absorptances, as well as on the hourly varying position of the sun relative to the space. It also depends on the hourly varying proportions of direct and diffuse solar radiation entering the space. Since you can enter only one set of SOLAR-FRACTIONS for a SPACE, the SOLAR-FRACTIONS should be chosen to represent a time-average over the run period of the

analysis, with emphasis given to those times of day and seasons of the year when solar gain is greatest. Note that SOLAR-FRACTION is not affected by MULTIPLIER; it applies to the surface area after multiplication.

INF-COEF

Specifies an infiltration flow coefficient used to compute the infiltration resulting from cracks in an exterior wall or roof. This entry is required if the crack method (INF-METHOD = CRACK) is specified in SPACE. For walls that use response factors to calculate heat flow and that use the crack method, the coefficient is used in the following equation for determining infiltration:

$$cfm = \text{INF-COEF} * dP^{0.8} * \text{Area}$$

where

- cfm infiltration airflow (cfm)
- dP pressure difference between outside and inside air (inches of water)
- Area wall surface area (ft²)

INF-COEF should not be used if INPUT-UNITS = METRIC. Table 7 shows typical values for INF-COEF.

Table 7 Infiltration Coefficients for Walls with TYPE=LAYERS Construction

Construction	cfh/ft ² wall	INF-COEF
13" brick w/plastered surface	(0.01)	0.002
13" brick, furring, lath, plaster	(0.03)	0.005
Frame wall, lath and plaster	(0.09)	0.016
8-1/2" brick, plain	(5.0)	0.915
16" shingles on shiplap w/building paper	(0.5)	0.092
16" shingles on shiplap	(8.0)	1.465
16" shingles on 1x4 boardson 5" center	(40.01)	7.324

The values in parentheses are typical infiltration values in cfh/ft² for a 7.5 mph wind normal to the surface of the given wall (7.5 mph (0.05 inches of water).

For walls that have a CONSTRUCTION with TYPE=U-VALUE, the following equation is used:

$$cfm = \text{INF-COEF} * dP^{0.5} * L$$

where now

- L wall perimeter (ft)

Table 8
Infiltration Coefficients for Walls with TYPE=U-VALUE construction

Construction	INF-COEF
1/8-in crack (0.3 cfm/ft)	1.342
1/4-in crack (0.5 cfm/ft)	2.236
1/2-in crack (1.1 cfm/ft)	4.919

SURFACE-TYPE

Takes a code-word that is used to set the default TILT value for the wall. CEILING or ROOF give TILT=0, FLOOR gives TILT = 180, WALL gives TILT=90. These values can be overridden by specifying the TILT keyword.

SHADING-SURFACE

Accepts code-words YES and NO that tell the program that this exterior surface shades other surfaces. YES causes this EXTERIOR-WALL surface to be considered also as a BUILDING-SHADE surface with TRANSMITTANCE = 0. Whenever an exterior wall is capable of shading another exterior surface (for example, in an L-shaped building), setting SHADING-SURFACE = YES greatly simplifies shading surface input. See "Building Shades" in the *DOE-2.2 Topics*.

SHADING-DIVISION

An integer value that specifies the number of divisions by which an exteriorstrips that the wall is divided into for shading calculations. The larger the number of shading divisions, the longer time the shading computations will require; however, the results will be more accurate. If the estimated effect of the shading on the overall building load is large, use more (20 to 40) divisions. If the estimated effect of the shading on the overall building load is small, use fewer (1-10) divisions.

GND-FORM-FACTOR

Fraction of the hemisphere facing the wall that is subtended by the ground, adjacent buildings, trees, hills, etc. GND-FORM-FACTOR and SKY-FORM-FACTOR are used in the diffuse radiation calculation. Either both or neither of these keywords should be specified. If not specified, the program will calculate them. These values will override the automatic diffuse shading calculation for the exterior wall and for any window or door in that wall.

SKY-FORM-FACTOR

Fraction of the hemisphere facing the wall that is subtended by the open sky. See note under keyword GND-FORM-FACTOR.

INSIDE-SOL-ABS

Inside surface solar absorptance. The fraction of the solar radiation incident on the opaque part of the wall from the inside that is absorbed (the rest being reflected). The program uses the INSIDE-SOL-ABS values to (1) determine the inside solar radiation distribution in sunspaces (see "Sunspaces" in the *DOE-2.2 Topics*); and (2) to calculate SOLAR-FRACTIONS when not all SOLAR-FRACTIONS in a space have been specified (see SOLAR-FRACTION keyword, above). Note that SOLAR-FRACTION and INSIDE-SOL-ABS for a surface are related but are not generally equal.

INSIDE-VIS-REFL

Inside surface visible reflectance (hemispherical average) of the opaque part of a wall, floor, or ceiling. Used only for daylighting calculation.

OUTSIDE-EMISS

Infrared (IR) emissivity of the outside surface of the wall. Used to determine IR radiation leaving the wall and IR radiation from sky, ground and other surfaces absorbed by the wall. Table 9 gives emissivity values of typical surface finishes.

Table 9 Emissivity of Different Exterior Surfaces*

Surface	Emissivity
Aluminum sheet	0.12
Steel, galvanized, bright	0.25
Regular glass	0.84
Building materials (wood, masonry, non-metallic paints)	0.90

* From 1985 ASHRAE Fundamentals, p.23-5

FUNCTION

Invokes a function calculation for this wall. See the "Input Functions" section in the *DOE-2.2 Topics*.

FIXED-SHADE

Specifies the position, size, orientation, and transmittance of stationary shading surfaces that remain fixed with respect to the surface of the earth when the building is translated or rotated. When the location or orientation of a building changes, shading surfaces that are defined using the BUILDING-SHADE command move with the building. Use the FIXED-SHADE command to describe shading surfaces (such as neighboring buildings, perhaps) that do *not* move with the building. The keywords for FIXED-SHADE are the same as those for BUILDING-SHADE except for X, Y and Z, which for FIXED-SHADE are replaced by X-REF, Y-REF, and Z-REF. U-name is optional. LIKE may be used to copy a previously-defined FIXED-SHADE. See "Building Shades" in the *DOE-2.2 Topics*.

Example input:

```

FS-1 = FIXED-SHADE
    HEIGHT           = 20
    WIDTH            = 50
    X-REF            = 50
    YREF             = 60
    ZREF             = 0
    AZIMUTH          = 30 ..

```

HEIGHT

Height of the shading surface.

WIDTH

Width of the shading surface.

X-REF, Y-REF, Z-REF

X-REF, Y-REF, and Z-REF give the position of the lower left hand corner (when looking into the surface outward normal) of a fixed shade in the reference coordinate system. The reference coordinate system is a coordinate system that is fixed with respect to the surface of the earth. Its y-axis points north and its x-axis points east. The reference coordinate system is used only when fixed shades are present. Then it is also necessary to position the building in the reference coordinate system in order to obtain the proper geometrical relationship between the fixed shades and the building. This is done by assigning values to the X-REF and Y-REF keywords of the BUILD-PARAMETERS command.

AZIMUTH

Angle (in degrees + or -) between the y-axis (north) of the reference coordinate system and the shading surface's outward normal.

TILT

Angle between the vertical and the shading surface's outward normal. Vertical shading surfaces have TILT=90.

TRANSMITTANCE

Fraction of incident solar radiation that is transmitted by the shading surface. The default value is 0.0, which means the surface is opaque. If the surface is transparent, the value to enter would be 1.0. Other values may be specified as a decimal fraction between these limits. Using SHADE-SCHEDULE allows seasonal variation in transmittance. Daylighting calculation assumes TRANSMITTANCE = 0.

SHADE-SCHEDULE

Takes the U-name of a schedule of TYPE=MULTIPLIER that gives the time-dependent transmittance of the shading device for direct (beam) solar radiation. The values in the schedule override the TRANSMITTANCE value. The range of the schedule values is 0.0 to 1.0. A value equal to 0.0 represents an opaque device; a value greater than

0.0 represents a device that passes some solar radiation, such as a tree, lattice, or fabric. Used only to simulate variable exterior shading devices. The program calculates direct solar shading factors for sun positions on the first day of each month, so only the SHADE-SCHEDULE values on those particular days are used. Also, the program calculates diffuse solar shading factors only once (before the hourly loads calculation); this means that SHADE-SCHEDULE has no effect on diffuse shading and the TRANSMITTANCE value is used instead. Daylighting calculation assumes TRANSMITTANCE = 0

SHADE-VIS-REFL

Visible reflectance of that side of a BUILDING-SHADE from which the outward normal points. The other side of the shading surface is assumed to be black, i.e., to have zero reflectance. Used only for daylighting calculation. See "Daylighting" in the *DOE-2.2 Topics*.

SHADE-GND-REFL

Visible reflectance of the ground in the vicinity of the BUILDING-SHADE. Used only for daylighting calculation. See "Daylighting" in the *DOE-2.2 Topics*.

FLOOR

Specifies the geometry of a floor of a building. This command is provided as a convenient way of grouping spaces together on a floor-by-floor basis. The SPACES entered right after a FLOOR command belong to that floor. If no FLOOR commands are specified, the program creates a fictitious floor whose coordinate system is the same as the building system and assumes that all spaces are in that floor. See "Geometry" in the *DOE-2.2 Topics*.

Example input:

```

SECONDFL = FLOOR
  X           = 0
  Y           = 0
  Z           = 12
  AZIMUTH    = 0 ..
    
```

X
Y
Z

X, Y, and Z give the position of the origin of the floor's coordinate system in the building coordinate system.

AZIMUTH

Angle between the y-axis of the building coordinate system and the y-axis of the floor's coordinate system. Positive values are measured clockwise; negative values are measured counter-clockwise.

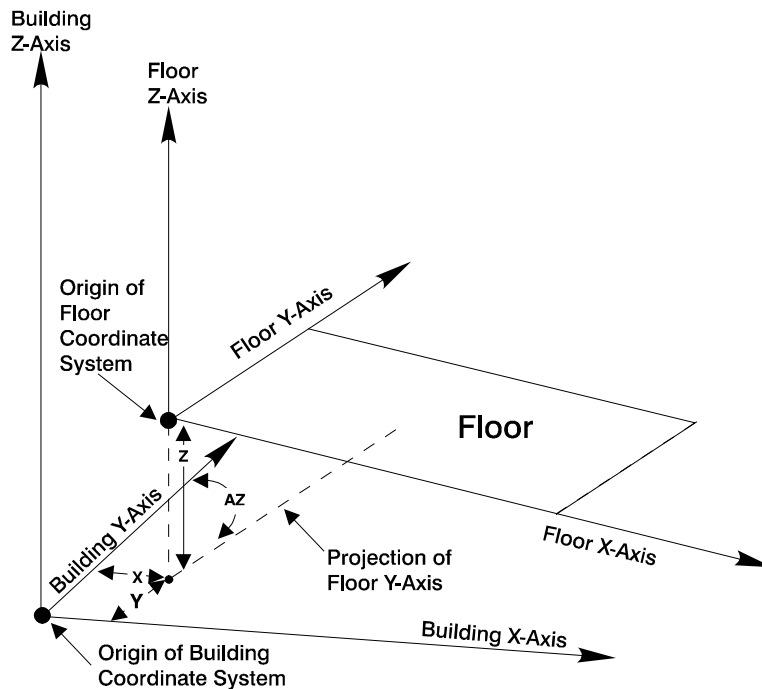

Figure 7 Positioning a floor in the building coordinate system

MULTIPLIER

The number of identical floors. Space loads are multiplied by this value (as well as by any SPACE multiplier).

FLOOR-HEIGHT

Specifies the overall floor-to-floor height of this floor, including any plenums located above the spaces.

SPACE-HEIGHT

Sets the default value for the HEIGHT keyword for all SPACES of ZONE-TYPE=CONDITIONED or UNCONDITIONED that are attached to this floor.

The HEIGHT of SPACES with ZONE-TYPE = PLENUM is the difference between the FLOOR-HEIGHT and the SPACE-HEIGHT

SHAPE

Accepts a code-word defining the method used to define the floor shape

BOX	indicates that the FLOOR is box-shaped. In this case, values must be given for the box dimensions WIDTH, and DEPTH. AREA and VOLUME should not be entered.
POLYGON	indicates that the FLOOR shape will be given by a polygon referenced with the POLYGON keyword. In this case, WIDTH, DEPTH, AREA and VOLUME should not be entered.
NO-SHAPE	indicates that the floor does not have a shape. The AREA and VOLUME must be entered.

WIDTH

When SHAPE=BOX, specifies the floor width.

DEPTH

When SHAPE=BOX, specifies the floor depth.

POLYGON

When SHAPE=POLYGON, takes the U-name of a POLYGON command that represents the footprint of the floor.

AREA

When SHAPE=NO-SHAPE, specifies the net floor area.

VOLUME

When SHAPE=NO-SHAPE, specifies the net floor volume.

GLASS-TYPE

Specifies the type of glass in a window. U-name must be used so that GLASS-TYPE may be referenced in a WINDOW instruction. LIKE may be used to copy a previously defined GLASS-TYPE. See "Windows" in the *DOE-2.2 Topics*.

TYPE

Takes a code-word that determines the method of calculating the glass heat transfer and solar gain. This is a required keyword.

GLASS-TYPE-CODE	indicates that glass data will be selected from windows in the library
SHADING-COEF	indicates that the glass shading coefficient will be specified and the ASHRAE shading coefficient method will be used for the window solar-thermal calculation

GLASS-TYPE-CODE

When TYPE=GLASS-TYPE-CODE, used to select a glazing from the library, which contains about 250 entries covering commonly-available glazings as well as experimental electrochromic glazings. Takes an integer value indicated by G-T-C in the *DOE-2.2 Libraries & Reports*, "Window Library".

Example input:

Select from the library a low-E clear double-pane glazing with 6 mm glass and 12 mm gap filled with argon gas (G-T-C number 2635 in *DOE-2.2 Libraries & Reports*, "Window Library").

```

GT-1 = GLASS-TYPE
      TYPE           = GLASS-TYPE-CODE
      GLASS-TYPE-CODE = 2635 . .

WIN-1 = WINDOW
      X              = 12
      Y              = 3
      HEIGHT         = 4
      WIDTH          = 5
      GLASS-TYPE     = GT-1 . .
  
```

GLASS-PROP-CALC

When TYPE=GLASS-TYPE-CODE, accepts a code-word that specifies the method that is to be used to calculate the angular dependence of glass properties. The data for solar transmission, visible transmission, and layer-by-layer solar absorption are calculated by the Window program and input using the GLASS-TYPE-CODE command. The Window program provides ten values for each transmission (solar and visible) and absorption (up to five glass layers); a value for angles of 0 to 90 degrees at increments of 10 degrees. This keyword allows the choice of two alternative methods of using this data in the hourly calculation of glass performance. The choices are as follows:

QUICK-FIT	Use a two coefficient fit to the Window program values. The default as was used in DOE-2.1E.
INTERPOLATION	Use the ten values calculated by the Window program with linear interpolation between the values. A more accurate and also faster calculation method not available in DOE-2.1E.

SHADING-COEF

When TYPE=SHADING-COEF is entered, the program first calculates the solar heat gain using transmission and absorption coefficients for a reference glazing (clear, 1/8" thick, single-pane, double-strength sheet glass). This solar heat gain is then multiplied by the value of SHADING-COEF to determine the resultant solar heat gain.

The shading coefficient depends, in general, not only on the type of glass but also on whether blinds, shades, draperies, etc., are used with the window. To simulate operable shading devices, assign a SHADING-SCHEDULE to a window (see the WINDOW command) and the resultant solar heat gain each hour will be multiplied by the schedule value.

For shading coefficient values of different glazing types with and without shading devices, see manufacturers' data sheets or the ASHRAE 1989 Handbook of Fundamentals, p. 27.26ff.

We strongly recommend that exterior WINDOWS in a sunspace be described with TYPE=GLASS-TYPE-CODE rather than SHADING-COEF. This allows the program to accurately calculate the hourly direct and diffuse radiation transmitted by the glazing. This is not possible with SHADING-COEF except for standard 1/8" clear glass.

VIS-TRANS

Visible (daylight) transmittance of glazing at normal incidence. Values from glass manufacturer's product data sheets vary from about 0.90 for clear, 1/8" sheet glass, to about 0.05 for some kinds of reflective, heat-absorbing glazing. Visible transmittance, which determines how much daylight is transmitted by the glass, should not be confused with total solar transmittance, which determines how much solar radiation (ultraviolet, visible, and infrared) is transmitted. This keyword is used only if the window is in a space with DAYLIGHTING=YES.

GLASS-CONDUCTANCE

The conductance of the glazing, excluding the outside air film coefficient. The conductance given in glass manufacturers' data sheets usually includes the outside air film resistance for a wind speed of 7.5 mph (summer) or 15 mph (winter). Table 10 can be used to obtain the corresponding value of GLASS-CONDUCTANCE. For example, if $U(7.5 \text{ mph}) = 0.64 \text{ Btu/ft}^2\text{-hr-F}$, then $\text{GLASS-CONDUCTANCE} = 0.79$ (by interpolation). For U-values of different glazing types, see manufacturers' data sheets or the ASHRAE 1989 Handbook of Fundamentals, p. 27.16-17.

Table 10
Correspondence between Glass manufacturers U-value and GLASS-CONDUCTANCE
(excluding outside air film) [all values are in Btu/ft2-hr-F (W/m2-K)]

U-Value (including outside air film)	GLASS CONDUCTANCE	
	(7.5 mph wind speed)	(15 mph wind speed)
0.1 (0.57)	0.10 (0.57)	0.10 (0.57)
0.2 (1.14)	0.21 (1.19)	0.21 (1.19)
0.3 (1.70)	0.33 (1.87)	0.32 (1.82)
0.4 (2.27)	0.45 (2.56)	0.43 (2.44)
0.5 (2.84)	0.59 (3.35)	0.55 (3.12)
0.6 (3.41)	0.73 (4.14)	0.68 (3.86)
0.7 (3.97)	0.89 (5.05)	0.81 (4.60)
0.8 (4.54)	1.05 (5.96)	0.95 (5.39)
0.9 (5.11)	1.23 (6.98)	1.09 (6.19)
1.0 (5.68)	1.43(8.12)	1.24 (7.04)
1.1 (6.25)	1.64 (9.31)	1.40 (7.95)
1.2 (6.81)	1.87 (10.62)	1.57 (8.91)
1.3 (7.38)	2.13 (12.09)	1.74 (9.88)

OUTSIDE-EMISS

Outside surface IR emissivity of glazing. The default value (0.84) can be used for uncoated glass. Glass with an outside surface metallic coating would have OUTSIDE-EMISS between about 0.03 and 0.4 depending on the type of coating. Used to determine IR radiation leaving the glass and absorbed by the glass.

Example input:

```
GT-2 = GLASS-TYPE
TYPE = SHADING-COEF
SHADING-COEF = 0.45
GLASS-CONDUCTANCE = 0.33
VIS-TRANS = 0.51 ..
```

HOLIDAYS

Defines a set of holidays for the simulation. Holidays can be assigned special day-schedules using the HOL command in the WEEK-SCHEDULE command.

Example input:

Specify that only February 15, May 7, and August 1 are holidays.

```
HOLIDAYS
  TYPE           = ALTERNATE
  MONTHS         = ( 2 , 5 , 8 )
  DAYS           = ( 15 , 17 , 1 ) . .
```

TYPE

specifies the type of holiday format to be used:

- | | |
|-------------|--|
| NONE | specifies that there are no holidays. In this case the keywords MONTHS and DAYS should not be entered. |
| OFFICIAL-US | specifies that the holidays are the U.S. Federal National Holidays (see Table 11). In this case, the keywords MONTHS and DAYS should not be entered. |
| ALTERNATE | specifies that the holidays are those given by the MONTHS and DAYS keywords. |

MONTHS

Takes a list of up to 60 integers that indicates the months that holidays occur.

DAYS

Takes a list of up to 60 integers that indicates the days of the month that holidays occur. The MONTHS and DAYS list should correspond. For example, two holidays, one in month 1, day 1, and another in month 6, day 5, would be entered as

```
HOLIDAYS
  TYPE           = ALTERNATE
  MONTHS         = ( 1 , 6 )
  DAYS           = ( 1 , 5 )
```

Note that the day of the month on which a holiday falls may vary from year to year. For example, a holiday may always be on a Monday. In this case, the day numbers in your DAYS list will depend on the year you specify in the RUN-PERIOD command.

Table 11 Official United States National Holidays

Holiday Name	Holiday is Celebrated on this Day
New Years Day	December 31 if a Friday January 1 (unless on Saturday or Sunday) January 2 if a Monday
M.L. King Birthday	Third Monday in January
Washington's Birthday	Third Monday in February
Memorial Day	Last Monday in May
Fourth of July	July 3 if a Friday July 4 (unless on Saturday or Sunday) July 5 if a Monday
Labor Day	First Monday in September
Columbus Day	Second Monday in October
Veterans Day	November 10 if a Friday November 11 (unless on Saturday or Sunday) November 12 if a Monday
Thanksgiving	Fourth Thursday in November
Christmas	December 24 if a Friday December 25 (unless on Saturday or Sunday) December 26 if a Monday

INTERIOR-WALL

Specifies the geometry, construction, and adjacent space for an interior wall, ceiling, or floor. An INTERIOR-WALL conducts heat from one space to another. Each INTERIOR-WALL applies to the SPACE instruction preceding. It is important NOT to input INTERIOR-WALLs twice. This is usually done by accidentally specifying the same interior wall under two adjacent SPACES. If you specify the same U-name in both SPACES for the same INTERIOR-WALL, the program aborts with a diagnostic message. However, if different U-names are specified in the two SPACES for the same INTERIOR-WALL, the program accepts the data with no diagnostic message. The heat transfer area is, however, now double that intended. Also, LOCATION is used only when SHAPE = BOX in the SPACE. LOCATION may be used whether or not Custom Weighting Factors are used. When specifying LOCATION, do not specify AREA or HEIGHT and WIDTH; this information is obtained by the program from your input for the SPACE command. U-name may be used to identify each wall. LIKE may be used to copy a previously U-named INTERIOR-WALL. See "Interior Surfaces" in the *DOE-2.2 Topics*.

Example input:

```
PARTITION-1 = INTERIOR-WALL
HEIGHT           = 8
WIDTH           = 20
CONSTRUCTION-FRAME = 1
NEXT-TO         = LOBBY . .
```

INT-WALL-TYPE

Specifies the type of interior wall through code-words that identify the type of heat transfer that occurs across the wall.

STANDARD

The default. Designates an interior wall that separates two spaces and conducts heat between the spaces. It can be defined with a CONSTRUCTION with TYPE=U-VALUE or TYPE=LAYERS although the heat storage effects of the wall are accounted for only if TYPE=LAYERS. If you choose a CONSTRUCTION with TYPE=U-VALUE, the U-value should be less than 0.709 Btu/ft²-F-hr (4.02 W/m²-K), which is the limiting value for two air films and a very low resistance solid layer.

The NEXT-TO keyword is required for this wall type. However, if the NEXT-TO space is the same as the space in which the wall was defined, the program will change INT-WALL-TYPE to ADIABATIC.

ADIABATIC

Designates an interior surface that does not conduct heat between spaces but can store heat. This type should be used to separate spaces that are considered to be identical and are, therefore, defined with MULTIPLIER or FLOOR-MULTIPLIER in the SPACE command. An example is the wall, ceiling, or floor that separates identical spaces that are side-by-side on one floor of a building or above one another in a multistory building. This type of wall should have delayed construction.

INTERNAL

Designates an interior surface that lies completely inside a space. An example is a water wall used to store solar energy in a space. Another example is a wall between two rooms that are modeled as a single space. This type of wall should have a construction with TYPE=LAYERS; in this case the thermal mass of the wall will be considered in the space's custom weighting factor calculation

AIR

Designates a non-physical interior surface with no mass (i.e., an opening between spaces) across which convection can take place. This type of wall should have a CONSTRUCTION with TYPE=U-VALUE. In this case, we recommend an approximate U-value of 2.7 Btu/ft²-hr (15.3 W/m²). The NEXT-TO keyword is required for this wall type.

If the "AIR wall" is part of a daylit space, its INSIDE-VIS-REFL values need to be specified (even though it is not a physical wall) since daylight can be reflected back across the AIR wall from the adjacent space. The values to use for INSIDE-VIS-REFL in this case are determined as follows. Assume that the AIR wall, of area A, is defined in space 1 and separates space 1 and space 2. Let the spaces have inside surface area S_i (excluding the AIR wall) and area-weighted visible reflectance ρ_i excluding the AIR wall). Then INSIDE-VIS-REFL=(R₂ , R₁) where R_i is the cavity reflectance of space i given by

$$R_i = A * \rho_i / (S_i - (S_i - A) * \rho_i)$$

CONSTRUCTION

This is a mandatory entry. Takes the U-name of a previously defined or library CONSTRUCTION command that describes the construction of this interior wall.

NEXT-TO

U-name of the adjacent space that shares this wall. Required if INT-WALL-TYPE = STANDARD or AIR; otherwise, unused.

LOCATION

Accepts a code-word defining the location of the wall in the space:

1. If the wall is in a SPACE with SHAPE=BOX, then TOP, BOTTOM, LEFT, RIGHT, FRONT, or BACK is used to indicate on which face of the box the wall is located. From this, and the SPACE keywords HEIGHT, WIDTH, and DEPTH, the program determines the wall's values of X, Y, Z, HEIGHT, WIDTH, AZIMUTH, and TILT.
2. If the wall is in a SPACE with SHAPE = POLYGON, then SPACE-V1, SPACE-V2, etc. are used to orient and size the wall in SPACES where the POLYGON keyword is used to specify the footprint of the SPACE. LOCATION=SPACE-V1 means that the lower left hand corner of the wall is located at the vertex 1 of the SPACE POLYGON. The program then positions the wall so that it is vertical (TILT=90) and its x-axis passes through vertex 1 and vertex 2 of the SPACE POLYGON (which determine the wall's AZIMUTH). The wall HEIGHT is set to HEIGHT of the SPACE and the wall WIDTH is set to the vertex 1 to vertex 2 distance. A similar procedure is followed for LOCATION=SPACE-V2, SPACE-V3, etc. If LOCATION=TOP (BOTTOM) the wall is positioned as a ceiling (floor) of the SPACE, with a shape that is the same as the SPACE's POLYGON.
3. If the wall is in a SPACE with SHAPE = NO-SHAPE, then this keyword is unused. Instead, you should specify the X, Y, Z, HEIGHT, WIDTH, AZIMUTH, and TILT

**X
Y
Z**

If the wall is in a SPACE with SHAPE = NO-SHAPE, then gives the coordinates (in the coordinate system of the space in which the wall is defined) of the lower left-hand corner of the wall when viewed from the NEXT-TO (see Figure 8).

AZIMUTH

If the wall is in a SPACE with SHAPE = NO-SHAPE, then gives the azimuth of the wall in the coordinate system of the space in which the wall is defined. The outward normal used to determine the azimuth points into the NEXT-TO space (see Figure 8).

SURFACE-TYPE

If the wall is in a SPACE with SHAPE = NO-SHAPE, then takes a code-word that is used to set the default TILT value for the wall. CEILING or ROOF give TILT=0, FLOOR gives TILT = 180, WALL gives TILT=90. These values can be overridden by specifying the TILT keyword..

TILT

If the wall is in a SPACE with SHAPE = NO-SHAPE, then gives the inclination of the interior wall from the z-axis of the space coordinate system. A horizontal ceiling has TILT=0. A floor has TILT=180. A vertical wall has TILT=90 (the default). Otherwise, the tilt defaults to the wall's location in its space.

POLYGON

Takes the U-name of a previously-defined POLYGON command. Used to assign a non-rectangular shape to the wall. If specified, then neither HEIGHT, WIDTH, nor AREA should be entered.

HEIGHT

If the wall is in a SPACE with SHAPE = NO-SHAPE, then gives the height of the wall; i.e., dimension parallel to the y-axis in the surface coordinate system. HEIGHT and WIDTH are used together to determine the area of the wall. If specified, do not enter AREA.

WIDTH

If the wall is in a SPACE with SHAPE = NO-SHAPE, then gives the width of the wall; i.e., dimension parallel to the x-axis in the surface coordinate system. HEIGHT and WIDTH are used together to determine the area of the wall. If specified, do not enter AREA.

AREA

If the wall is in a SPACE with SHAPE = NO-SHAPE, then gives the surface area. If specified, do not enter HEIGHT or WIDTH.

INSIDE-VIS-REFL

Inside surface visible reflectance (hemispherical average) used in the daylighting calculation to determine interreflected illuminance. Takes a list of two values, where the first value is the reflectance on the side of the interior wall that is in the space in which the wall is defined; the second value is the reflectance on the other side of the wall. INSIDE-VIS-REFL values default to 0.2 for floor surfaces, 0.5 for wall surfaces, and 0.7 for ceiling surfaces. See "Daylighting" in the *DOE-2.2 Topics*.

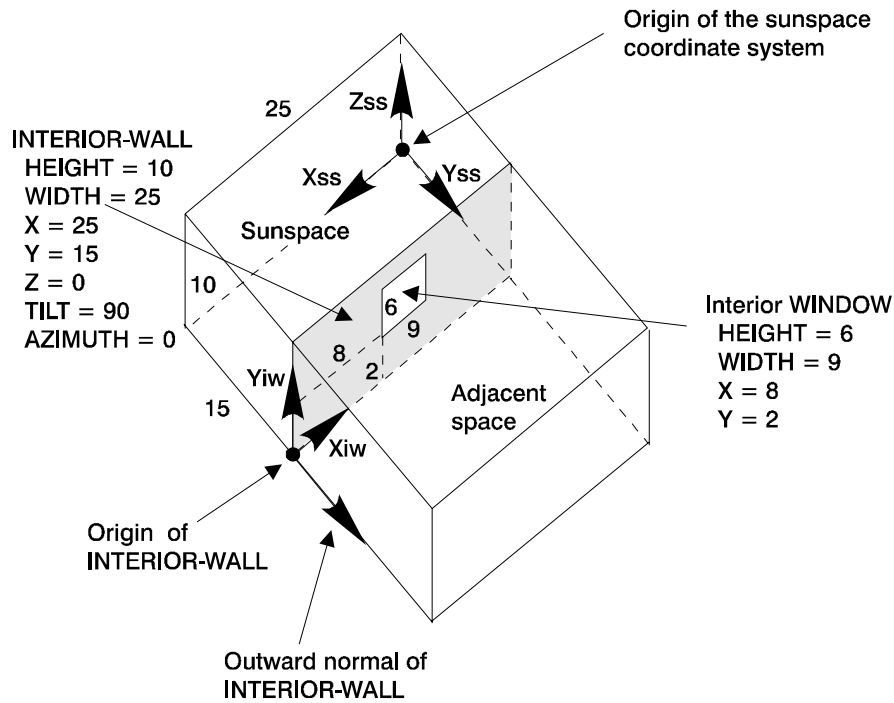

Figure 8 Positioning an interior-wall in the Space Coordinate System.
 (A sunspace and an adjacent space showing the geometrical positioning of the INTERIOR-WALL separating them. The INTERIOR-WALL has been defined in the sunspace. The lower left-hand corner of the wall (as viewed from the adjacent space) is located at X = 25, Y = 15, Z = 0 in the sunspace coordinate system. The azimuth of the INTERIOR-WALL is 0 (, which is the angle between the sunspace y-axis, Yss, and the outward normal to the INTERIOR-WALL)

SOLAR-FRACTION

Fraction of the solar radiation-direct, diffuse, and reflected-that comes through the glazings and is absorbed by this wall. First value in the list of two is for the side of the wall that is in the space in which the wall is defined; the second value is for the side of the wall that is in the NEXT-TO space. The program uses the SOLAR-FRACTION values to calculate custom weighting factors for space solar gain.

If all SOLAR-FRACTIONS for a space area are allowed to default, the program assumes that 60 percent the incoming solar radiation is absorbed by the floor with the remaining 40 percent distributed to other surfaces (except windows), according to their surface area. If there is no floor, the full 100 percent is distributed to the surfaces (except windows) according to their surface areas. To override this default, you can explicitly specify SOLAR-FRACTION values for all or just some of the surfaces. If just some of the surfaces, the program will sum the values specified and distribute the balance (up to 1.0) to the other surfaces.

The distribution of absorbed solar radiation depends on the space geometry and surface absorptances as well as on the hourly varying position of the sun relative to the space. It also depends on the hourly varying proportions of direct and diffuse solar radiation entering the space. Since you can only enter one set of SOLAR-FRACTIONS for a SPACE, the SOLAR-FRACTIONS should be chosen to represent a time-average over the intended RUN-PERIOD of the analysis, with emphasis given to those times of the day and seasons of the year when solar gain is greatest.

SOLAR-FRACTION is not affected by MULTIPLIER; it applies to the surface area after multiplication. Example input: the side of the wall towards the space in which the wall is defined absorbs 20 percent of the solar radiation entering that space. The other side absorbs 15 percent of the solar radiation entering the NEXT-TO space. Then SOLAR-FRACTION=(0.20, 0.15)

INSIDE-SOL-ABS

Inside surface solar absorptance. It is used hourly to determine the interior solar radiation distribution in a sunspace. Takes a list of two values is required; the first value is the absorptance on the side of the interior wall inside the space in which the wall is defined; the second value is the absorptance of the other side of the wall. INSIDE-SOL-ABS values default to 0.8 for floor surfaces, 0.5 for wall surfaces, and 0.3 for ceiling surfaces. See "Sunspaces" in the *DOE-2.2 Topics*.

LAMP-TYPE

This optional command specifies the type of lamp in an electric lighting system. Must be assigned a U-name so it can be referenced by the LAMP-TYPE keyword in the LIGHTING-SYSTEM command. See "Electric Lighting" in the *DOE-2.2 Topics*.

Example input:

```

FLUOR-1 = LAMP-TYPE
  CATEGORY      = FULL-SIZE-FLUOR
  SIZE          = T-48-IN
  POWER-INPUT   = 32
  INIT-LUMEN-OUT = 2850
  LUMEN-DEPREC  = 0.84 . .

```

CATEGORY

Takes a code-word that specifies the type of lamp.

FULL-SIZE -FLUOR	A low-pressure mercury electric-discharge lamp in which a phosphor transforms some of the UV energy generated by the discharge into light. Tube length generally about 12 in (30 cm) or longer.
COMPACT-FLUOR	Same as FULL-SIZE-FLUOR, but with a smaller tube, generally about 6 in (15 cm) or less.
INCANDESCENT	A lamp in which light is produced by a filament heated by an electric current.
TUNGSTEN-HALOGEN	An incandescent lamp with a tungsten filament in an inert gas containing halogens.
HID-HI-PR-SODIUM	High-intensity discharge (HID) lamp. Light is produced by an electric arc in a high pressure sodium vapor. The arc is stabilized by wall temperature and the arc tube has a bulb wall loading in excess of 3 W/cm ² .
HID-MET-HALIDE	Same as HID-HI-PR-SODIUM but the vapor contains mercury, argon and metal halides.

INIT-LUMEN-OUT

Light output in lumens after seasoning the lamp for 100 hours. For fluorescent lamps, this is the initial light output for the lamp operated on a laboratory reference ballast. The program calculates the actual light output taking thermal and ballast factors into consideration (for fluorescent lamps), then multiplying by LUMEN-DEPREC to account for lamp aging. Values of INIT-LUMEN-OUT can be found in lamp manufacturers' catalogs.

POWER-INPUT

The nominal lamp input power. Values can be found in lamp manufacturers' catalogs. The program calculates the actual, or "active" power from POWER-INPUT taking into account thermal and ballast effects, where applicable. For example, a fluorescent lamp with POWER-INPUT = 40 W in a LIGHTING-SYSTEM with LUMINAIRE-CONFIG = RECESS-STATIC and BALLAST-TYPE = ELEC-RAP-START might have an active power input of only 34 W.

LUMEN-DEPREC

Lumen depreciation, i.e., the ratio of lamp light output at 70 percent of life to initial light output. Accounts for the decrease in light output with age. Values can be found in lamp manufacturers' catalogs.

SIZE

The size of the lamp. The purpose of this keyword is to avoid using luminaires that are not matched to the lamp, which could lead the program to use inappropriate coefficients of utilization in the illuminance calculation. When LAMP-TYPE and LUMINAIRE-TYPE are referenced by a LIGHTING-SYSTEM command, the SIZE code-word in LAMP-TYPE must match the ACCEPT-LAMP-SIZE code-word in LUMINAIRE-TYPE. Allowed code-words are:

T-0-6-IN	T lamp up to 6 in (15 cm) long
T-6-12-IN	T lamp 6 to 12 in (15 to 30 cm) long
T-12-IN	12-in long T lamp.
T-18-IN	18-in long T lamp.
T-24-IN	24-in long T lamp.
T-36-IN	36-in long T lamp.
T-48-IN	48-in long T lamp.
T-60-IN	60-in long T lamp.
T-72-IN	72-in long T lamp.
T-84-IN	84-in long T lamp.
T-96-IN	96-in long T lamp.
ALPHA-0-21	Alpha shape lamp up to size 21 (21/8-in diameter)
ALPHA-22-30	Alpha shape lamp from size 22 to 30 (22/8-in to 30/8-in diameter)
ALPHA-31-50	Alpha shape lamp size 31 and above (31/8-in diameter and above)
REFL-0-21-IN	Reflective lamp up to size 21 (21/8-in diameter)
REFL-22-30-IN	Reflective lamp from size 22 to 30 (22/8-in to 30/8-in diameter)
REFL-31-50-IN	Reflective lamp size 31 and above (31/8-in diameter and above)
OTHER-SIZE	Designation you can use to force lamp/luminaire compatibility; useful when defining new lamps or for lamps that don't fall into above size categories.

LAYERS

Specifies the layers of material that are in a construction, the order of the layers, and the layer thicknesses. It initiates the calculation of response factors for the wall. The LIKE keyword is not allowed U-name must be used so that LAYERS may be referenced in a CONSTRUCTION instruction. The Library contains pre-assembled layers for exterior walls, roofs, and interior walls (see "Constructions" in *DOE-2.2 Libraries & Reports*).

Example input: One-ft-thick concrete block with a 1-inch-thick stucco exterior

```

CBLOCK = LAYERS           $from the Library$
      MATERIAL            = ("Stucco 1in (SC01)",
                           "CMU HW 12in ConcFill (CB17)")
      THICKNESS           = (0.0625, 1.00) ..

```

MATERIAL

Takes a list of material code-words from the Library, as shown in the above example, or a list of MATERIAL command U-names. The number of elements in the list is the number of layers in the construction. For an exterior wall, the elements in the list start with the exterior layer and end with the interior layer. Reversing this sequence can notably affect the thermal performance of a wall. Do not specify inside or outside air film as a material. See Appendix D, "Materials in the Library"

THICKNESS

Takes a list of the thickness of each material in the construction; overrides the thickness in the immediately preceding MATERIAL list. The order of the THICKNESS list must correspond to the order of the MATERIAL list. THICKNESS is required only if one or more of the materials has a thickness that is different from the library value.

INSIDE-FILM-RES

Specifies the combined convective and radiative air film resistance for the inside wall surface. The default of 0.68 hr-ft²-F/Btu (0.1198 m²-K/W) is an appropriate value for vertical walls. For horizontal surfaces, such as ceilings and floors, the suggested inside film resistance can be found in Table 12. Because only one value is allowed for each surface, you should decide which is more important, cooling or heating.

For radiant barriers having a low-emissivity surface (for example, aluminum foil or insulation with aluminum coating) facing the interior of the space, select the emissivity from Table 13 and then determine the INSIDE-FILM-RES value by interpolating the e=0.09, e=0.20 and e=0.05 columns of Table 12.

Table 12
INSIDE-FILM-RES values for position of surface, direction of heat flow and insidesurface emissivity.

Position of surface	Direction of heat flow	Surface emissivity		
		0.90*	0.20**	0.05***
<i>Ceiling in the heating mode or Floor in the cooling mode</i>				
Horizontal	Up	0.61 (0.11)	1.10 (0.19)	1.32 (0.23)
45(slope	Up	0.62 (0.11)	1.14 (0.20)	1.37 (0.24)
Vertical	Horizontal	0.68 (0.12)	1.35 (0.24)	1.70 (0.30)
45(slope	Down	0.76 (0.13)	1.67 (0.29)	2.22 (0.39)
<i>Ceiling in the cooling mode or Floor in the heating mode</i>				
Horizontal	Down	0.92 (0.16)	2.70 (0.48)	4.55 (0.80)
*Regular building materials: wood, masonry, non-metallic paints, paper **Polished aluminum coated paper, for example ***Bright aluminum foil, for example <p style="text-align: center;"><i>From 1997 ASHRAE Fundamentals, p.24.2</i></p>				

If you cannot decide which is more important, cooling or heating, you can use the average of the heating and cooling values. For exterior walls and roofs, the outside-film-resistance is calculated by the program depending on wind speed. For interior walls, the air film described in INSIDE-FILM-RES is the film on the side of the wall that is in the SPACE where the wall is specified. For the calculation of the U-Value of an INTERIOR-WALL, the INSIDE-FILM-RES is duplicated on the other surface (opposite side).

Table 13 IR Emissivity of Different Interior Surfaces

Surface	Emissivity
Aluminum foil, bright	0.05
Aluminum sheet	0.12
Aluminum coated paper, polished	0.20
Steel, galvanized, bright	0.25
Aluminum paint	0.50
Regular glass	0.84
Building materials (wood, masonry, non-metallic paints)	0.90
<i>From 1997 ASHRAE Fundamentals, p.24.2</i>	

Rules

1. The outside air film coefficient of an exterior wall or roof should not be specified as a layer because it is calculated by the LOADS program as a function of surface roughness and wind speed.
2. The list identified by MATERIAL and THICKNESS must have a one-to-one correspondence. For example, the first material listed in MATERIAL has a thickness equal to the first value listed in THICKNESS.
3. Both lists (MATERIAL and THICKNESS) must have the same number of elements.
4. A list element must be included in THICKNESS for layers specified by a RESISTANCE, but it is a dummy variable, used only to make the list length match with the MATERIAL list length.
5. For an exterior wall or roof, both lists start with the outside layer. For an UNDERGROUND-FLOOR or UNDERGROUND-WALL, the lists start with the layer in contact with the ground. For an INTERIOR-WALL, the lists start with the layer in contact with the air of the space adjacent to the space in which the INTERIOR-WALL is defined.
6. Maximum list length for MATERIAL and THICKNESS is 9 elements each.
7. Not all LAYERS can be specified by RESISTANCE (for MATERIAL) only. At least one must be specified as a transient type layer.

LIGHTING-SYSTEM

This optional command specifies the components of an overhead electric lighting system. Must be assigned a U-name so that it can be referenced by the LIGHTING-SYSTEM keyword in the SPACE command. See "Electric Lighting" in the *DOE-2.2 Topics*.

Example input:

```
LS-1 = LIGHTING-SYSTEM
    LTG-CALC-METHOD = LUMINAIRE-LAMP
    LUMINAIRE-TYPE    = LUM1
    LAMP-TYPE         = FLUOR-1
    BALLAST-TYPE      = ELEC-RAP-START . .
```

LTG-CALC-METHOD

Specifies the lighting calculation method. Allowed code-words are:

LUMINAIRE-LAMP The calculation of connected power and workplane illuminance for the LIGHTING-SYSTEM is based on luminaire and lamp data provided by the keywords LUMINAIRE-TYPE, LUMINAIRE-CONFIG, LAMP-TYPE and BALLAST-TYPE, which are described below.

LUMENS-POWER The calculation of connected power and workplane illuminance for the LIGHTING-SYSTEM is based on total luminaire input power, coefficient of utilization and lamp lumen output provided by the keywords TOT-POWER-INPUT, COEF-OF-UTIL and TOT-LAMP-LUMENS, which are described below.

Table 14 LIGHTING-SYSTEM keywords

LTG-CALC-METHOD	Associated LIGHTING-SYSTEM Keywords
LUMINAIRE-LAMP	LUMINAIRE-TYPE LUMINAIRE-CONFIG LAMP-TYPE BALLAST-TYPE
LUMENS-POWER	COEF-OF-UTIL TOT-LAMP-LUMENS TOT-POWER-INPUT

LTG-CALC-METHOD=LUMINAIRE-LAMP

The following four keywords are used with this calculation method

LUMINAIRE-TYPE

Accepts the U-name of a luminaire type from the Library (see *DOE-2.2 Libraries & Reports*) or the U-name of a previously-defined or library LUMINAIRE-TYPE command. A "luminaire" is taken here to be the fixture that houses the lamps and, where applicable, the lamp ballasts.

```

LUM-1 = LUMINAIRE-TYPE
  NO-OF-LAMPS      = 2
  ACCEPT-LAMP-SIZE = T-48-IN
  ACCEPT-CONFIG    = (RECESS-STATIC, RECESS-VENTED) . .

FLUOR-1 = LAMP-TYPE
  CATEGORY      = FULL-SIZE-FLUOR
  SIZE          = T-48-IN

LS-1 = LIGHTING-SYSTEM
  LTG-CALC-METHOD = LUMINAIRE-LAMP
  LUMINAIRE-TYPE    = LUM1
  LAMP-TYPE         = FLUOR-1
  BALLAST-TYPE      = ELEC-RAP-START
  LUMINAIRE-CONFIG = RECESS-VENTED . .
    
```

LUMINAIRE-CONFIG

Specifies the configuration of the luminaire, which the program uses in calculating thermal effects that influence lamp input power and light output. Allowed code-words are:

- RECESS-STATIC The luminaire is recessed into the ceiling and is not vented with supply or return air.
- RECESS-VENTED The luminaire is recessed into the ceiling and is vented with supply or return air.
- SURFACE-CLOSED The luminaire is attached to the ceiling surface and is covered by a lens that inhibits air circulation.
- SURFACE-OPEN The luminaire is attached to the ceiling surface and is not covered by a lens.
- SUSPEND-CLOSED The luminaire is suspended from the ceiling on a pendant and is covered by a lens that inhibits air circulation.
- SUSPEND-OPEN The luminaire is suspended from the ceiling on a pendant and is not covered by a lens.

LAMP-TYPE

Takes the U-name of a lamp type from the Library (see *DOE-2.2 Libraries & Reports*) or the U-name of a previously-defined LAMP-TYPE command.

BALLAST-TYPE

Specifies the type of ballast. BALLAST-TYPE is required only for fluorescent and HID lamps. Allowed code-words are:

- MAGN-PRE-1990 Pre-1990 magnetic ballast for full-size fluorescent lamps.
- MAGN-ENERGY-EFF Energy-efficient magnetic ballast for full-size fluorescent lamps.
- MAGN-HTR-CUT-RED Reduced light output heater cutout magnetic ballast for full-size fluorescent lamps.
- MAGN-HTR-CUT-FUL Full light output heater cutout magnetic ballast for full-size fluorescent lamps.
- ELEC-RAP-START Electronic rapid start ballast for full-size fluorescent lamps.

ELEC-RAP-ST-RED	Electronic reduced output rapid start ballast for full-size fluorescent lamps.
ELEC-INS-START	Electronic instant start ballast for full-size fluorescent lamps.
CF-MAGNETIC	Magnetic ballast for compact fluorescent lamps.
CF-ELECTRONIC	Electronic ballast for compact fluorescent lamps.
HID-MAGNETIC	Magnetic ballast for HID lamps.
HID-LO-LOSS-MAGN	Low-loss magnetic ballast for HID lamps.

LTG-CALC-METHOD=LUMENS-POWER

The following keywords are used with this calculation method.

COEF-OF-UTIL

The coefficient of utilization or CU; i.e., the fraction of light output from the lamp/luminaire combination that reaches the workplane. The CU depends on luminaire geometry, luminaire surface reflectances, dirt depreciation, luminaire/workplane distance, room geometry and room surface reflectances. COEF-OF-UTIL, TOT-LAMP-LUMENS (see following) and space floor area are used by the program to calculate the electric lighting design illuminance on the workplane. Values of COEF-OF-UTIL can usually be found in luminaire manufacturer's photometric data sheets.

TOT-LAMP-LUMENS

The total number of lumens output by all of the lamps in the LIGHTING-SYSTEM for the space. Equals the number of lamps times the lumen output from each lamp (which can be found in lamp manufacturer's data sheets). TOT-LAMP-LUMENS, COEF-OF-UTIL (see above) and space floor area are used by the program to calculate the electric lighting design illuminance on the workplane. The value of TOT-LAMP-LUMENS should be that at 70% of lamp life and should take into account the ballast factor (multiplier on nominal light output due to ballast/lamp interactions) and thermal effects.

TOT-POWER-INPUT

The total electrical power input in watts for the LIGHTING-SYSTEM at full power (i.e., all lights fully on). Also called "active power." Ballasts should be included where applicable. For fluorescent lamps, where thermal and ballast effects influence operating power, the user is cautioned not to set TOT-POWER-INPUT equal simply to the number of lamps times nominal watts per lamp.

LOADS-REPORT

Specifies which LOADS verification and summary reports are to be printed. The verification reports display the input in a reformatted form. The summary reports state the calculated loads. The time period covered in the summary reports are the RUN-PERIOD intervals. Additional reports are generated for the design-days.

Format:

```
LOADS-REPORT
  VERIFICATION      = (code-word list)
  SUMMARY           = (code-word list) ..
```

Example input:

```
LOADS-REPORT
  VERIFICATION      = (LV-A)
  SUMMARY           = (SS-A,SS-E) ..
```

VERIFICATION

Takes a list of code-words of verification reports. VERIFICATION = (ALL-VERIFICATION) causes all verification reports to be printed. Examples are shown in *DOE-2.2 Libraries & Reports*.

LV-A	General project and building input
LV-B	Summary of spaces occurring in the project
LV-C	Details of space <space name>
LV-D	Details of exteriorsSurfaces in the project
LV-E	Details of underground surfaces in the project
LV-F	Details of interior surfaces in the project
LV-G	Details of schedules occurring in the project
LV-H	Details of windows occurring in the project
LV-I	Details of constructions occurring in the project
LV-K	Weighting factor summary
LV-L	Daylight factor summary
LV-M	English/metric conversion table
ALL-VERIFICATION	All verification reports

SUMMARY

Takes a list of code-words of summary reports. SUMMARY = (ALL-SUMMARY) causes all summary reports to be printed. Examples are shown in *DOE-2.2 Libraries & Reports*.

LS-A	<p>PACE PEAK LOADS SUMMARY</p> <p>Gives monthly values of peak heating and cooling loads for a space.</p>
LS-B	<p>SPACE PEAK LOAD COMPONENTS</p> <p>Gives a breakdown of cooling and heating peak loads according to the source of the load for each space.</p>
LS-C	<p>BUILDING PEAK LOAD COMPONENTS</p> <p>Similar in format to LS-B; however, LS-C is generated at the "building level", i.e., the space loads are summed each hour to give the building coincident load and the peak values of this load are shown in this report.</p>
LS-D	<p>BUILDING MONTHLY LOADS SUMMARY</p> <p>Gives a summary of monthly cooling, heating, and electrical requirements plus annual total energy requirements and maximum monthly peak loads for conditioned spaces.</p>
LS-E	<p>SPACE MONTHLY LOAD COMPONENTS <space name></p> <p>Gives a breakdown of loads for each space on a monthly basis, according to the source of the load.</p>
LS-F	<p>BUILDING MONTHLY LOAD COMPONENTS</p> <p>Gives a breakdown of loads on a monthly basis for the entire building, according to the source of the load. Only conditioned spaces are included.</p>
LS-G	<p>SPACE DAYLIGHTING SUMMARY</p> <p>Gives monthly-average overhead lighting energy reduction, illuminance, and glare for each daylit space.</p>
LS-H	<p>LIGHTING ENERGY REDUCTION BY DAYLIGHT</p> <p>For each daylit space, gives the monthly lighting energy reduction due to daylighting for each hour of the day, and for all hours of the day combined (including night time hours).</p>
LS-I	<p>PERCENT LIGHTING ENERGY REDUCTION BY DAYLIGHT, BUILDING</p> <p>For the building as a whole, gives the monthly lighting energy reduction due to daylighting for each hour of the day and for all hours of the day combined (including night time hours).</p>
LS-J	<p>DAYLIGHT ILLUMINANCE FREQUENCY</p> <p>For each daylit space, gives the monthly daylight-illuminance frequency-of-occurrence distribution at each lighting reference point.</p>
LS-K	<p>SPACE INPUT FUELS SUMMARY</p> <p>Gives monthly summaries of the fuel inputs required by each space for lighting, equipment, and processes. Following the reports for each space is a separate building level report that gives the sum of the input fuels for the building as a whole. Lighting, equipment, and process are the three major sections of this report, which is printed once for each space and once for the building as a whole.</p>

LS-L

MANAGEMENT AND SOLAR SUMMARY

Gives monthly summaries of window shade management and solar radiation into space.

REPORT-FREQUENCY

Allows you to control the frequency at which hourly report data is printed. May be set to HOURLY, DAILY, MONTHLY or YEARLY. If REPORT-FREQUENCY is not specified, the program will generate reports with summary values (minimum, maximum, total, and average) printed at the end of each day and month, and at the end of the run period specified in the HOURLY-REPORT:REPORT-SCHEDULE. When REPORT-FREQUENCY is set to DAILY, the hourly data are suppressed and only summary values are printed for each day and at the end of the month and run period. Similarly, when REPORT-FREQUENCY is set to MONTHLY only the summary statistics for months and the run period are printed. YEARLY results in a single summary report covering the entire run period. Only scheduled hours are included in the summaries. Note that some averages may be misleading, e.g., the average solar altitude if the schedule contains night time hours during which the solar altitude values are zero.

HOURLY-DATA-SAVE

Specifies the method used to save data from an hourly report written by the LOADS program. This allows post processing or data viewing using an external program; examples could be a user written program or a third party program such as Microsoft® Excel. By default the value is NO-SAVE, so no added files are created and the HOURLY-REPORT data only appears in the formatted reports on the standard output file. Other code-words cause either formatted (text) or unformatted (binary) file(s) to be created in the local (project) directory (unless re-directed using environment variable to replace the filenames below) that contain the data from hourly report(s). The data is written to these files in a continuous stream, one record per hour, with the data in the same order as specified in the hourly report commands which is the same order that data appears in the standard output file formatted report. The data is written to the file(s) each hour any hourly report is scheduled ON. Allowed code-words are:

NO-SAVE

Do not create file(s) to save hourly report data.

BINARY

Open the data file(s) in binary mode and write the data using binary write statements. Reading these files will usually require a custom program that can read binary data files. One hourly data and two data header files are created. One data header file is binary and the other is formatted; they both contain identical records and data, just in these different formats. When using the command line version of DOE-2 the file names binary headers, binary data and text headers for the run are:

```
CECHR<num>.bin
CECDT<num>.bin
CECPRO.FMT
```

When using the DLL version of DOE-2 (as in eQUEST) the file names for the binary headers, binary data and text headers for the run are:

```
<project directory>/<project name>_HourlyDataHeaders<num>.bin
<project directory>/<project name>_HourlyData<num>.bin
<project directory>/<project name>_HourlyDataTitles.dat
```

FORMATTED

Open the data file in formatted (text) mode and write the data using formatted write statements. This type of file can easily be imported into programs such as Microsoft® Excel. One hourly data file is created with one text record per hour with the same format and order as the hourly reports on the standard output file; there are no blank or header records and all columns of data are fixed in position

and separated with one or more spaces. When using the command line version of DOE-2 the file name is:

CEC<prog>_<num>.dat

When using the DLL version of DOE-2 the file name is:

<project directory>/<project name>_HourlyData<prog>_<num>.dat

In the above file names <prog> is 1 for LOADS and 2 for HVAC and <num> is, 1 for the first LOADS calc, 2 for the first HVAC calc, 3 for the second LOADS calc, so on.

LUMINAIRE-TYPE

This optional command specifies the type of luminaire in an electric lighting system. A U-name must be assigned so this command can be referenced by the LUMINAIRE-TYPE keyword in the LIGHTING-SYSTEM command.

Example input:

```
LUM-1 = LUMINAIRE-TYPE          $ FLUORESCENT TROFFER,
                                $ 2'X4', 2 LAMPS,
                                $ PATTERN "ACRYLIC DIFFUSER"

NO-OF-LAMPS=2
ACCEPT-LAMP-SIZE =T-48-IN
ACCEPT-CONFIG    =( RECESS-STATIC )
CU-RCR-1         =( .69 , .71 , .72 , .71 , .73 , .75 , .72 , .77 , .80 )
CU-RCR-5         =( .41 , .45 , .49 , .41 , .45 , .50 , .42 , .46 , .52 )
CU-RCR-10        =( .22 , .25 , .30 , .22 , .25 , .30 , .22 , .26 , .32 ) ..
```

NO-OF-LAMPS

The number of lamps in the luminaire.

ACCEPT-LAMP-SIZE

The size/shape of lamp accepted by the luminaire. The purpose of this keyword is to avoid using lamps that are not matched to the luminaire, which could lead the program to use inappropriate coefficients of utilization in the illuminance calculation. Therefore, when LUMINAIRE-TYPE and LAMP-TYPE are referenced by a LIGHTING-SYSTEM command, the ACCEPT-LAMP-SIZE code-word in LUMINAIRE-TYPE must match the SIZE code-word in LAMP-TYPE.

The following code words use a common set of symbols:

T	A tube lamp (such as most full-size fluorescents)
ALPHA=	A lamp with a roundish, non-reflective glass bulb (common representatives are the A, PS, and ED shapes)
REFL	A lamp with a reflective bulb (common representatives are the R and PAR bulbs).

Acceptable code-words are:

T-0-6-IN	0 to 6 in (0 to 15 cm) long T lamp
T-6-12-IN	6 to 12 in (15 to 30 cm) long T lamp
T-12-IN	12-in long T lamp.
T-18-IN	18-in long T lamp.
T-24-IN	24-in long T lamp.
T-36-IN	36-in long T lamp.
T-48-IN	48-in long T lamp.

T-60-IN	60-in long T lamp.
T-72-IN	72-in long T lamp.
T-84-IN	84-in long T lamp.
T-96-IN	96-in long T lamp.
ALPHA-0-21	Alpha shape lamp up to size 21 (21/8-in diameter)
ALPHA-22-30	Alpha shape lamp from size 22 to 30 (22/8-in to 30/8-in diameter)
ALPHA-31-50	Alpha shape lamp size 31 and above (31/8-in diameter and above)
REFL-0-21-IN	Reflective lamp up to size 21 (2--1/8-in diameter)
REFL-22-30-IN	Reflective lamp from size 22 to 30 (22/8-in to 30/8-in diameter)
REFL-31-50-IN	Reflective lamp size 31 and above (31/8-in diameter and above)
OTHER-SIZE	Designation you can use to force lamp/luminaire compatibility; useful when defining new lamps or luminaires that don't fall into above size categories.

ACCEPT-CONFIG

Takes a list of up to three code-words that specify what configurations the luminaire can be used in. An error will result if none of the code-words match the value of LUMINAIRE-CONFIG in the associated LIGHTING-SYSTEM command that references this LUMINAIRE-TYPE. The allowed code-words are the same as those for the LUMINAIRE-CONFIG keyword in the LIGHTING-SYSTEM command.

Luminaire Dirt Depreciation

The next three keywords determine the luminaire dirt depreciation, i.e., the degradation in light output due to dirt accumulation.

LUM-MAINT-CAT

Takes a code-word that specifies the luminaire maintenance category. Luminaires are separated into six categories (I through VI). To arrive at a category, luminaires are arbitrarily divided into sections, a top enclosure and a bottom enclosure, by drawing a line through the light center of the lamp or lamps. The characteristics listed in Table 15 for the enclosures are then selected to determine the code-word that best describes the luminaire. Only one characteristic for the top enclosure and one for the bottom enclosure should be used in determining the category of a luminaire. The maintenance category is determined when there are characteristics in both enclosure columns. If a luminaire falls into more than one category, the lower numbered category is used.

Table 15 Luminaire Maintenance Categories

Maintenance Category Code-word	Top Enclosure Characteristics	Bottom Enclosure Characteristics
LUM-MAINT-I	None	None
LUM-MAINT-II	None, or Transparent or opaque with 15% or more uplight through apertures	None, or Louvers or baffles
LUM-MAINT-III	Transparent or opaque with less than 15% uplight through apertures.	
LUM-MAINT-IV	Transparent or opaque unapertured	None, or Louvers
LUM-MAINT-V	Transparent or opaque unapertured	Transparent unapertured
LUM-MAINT-VI	None, or Transparent or opaque unapertured	Transparent or opaque unapertured

OPERATING-ATMOS

Takes a code-word that specifies the condition of the atmosphere in which the luminaire will operate. Dirt in the atmosphere comes from two sources: that generated by work done in the vicinity and that passed from adjacent air. Table 16 can be used to choose the appropriate code-word.

Table 16 Operating Atmosphere

	VERY-CLEAN	CLEAN	MEDIUM	DIRTY	VERY-DIRTY
Generated Dirt	None	Very little	Noticeable but not heavy	Accumulates rapidly	Constant Accumulation
Ambient Dirt	None (or none enters area)	Some (almost none enters)	Some enters area	Large amount enters area	Almost none excluded
Removal or filtration	Excellent	Better than average	Poorer than average	Only fans or blowers if any	None
Adhesion	None	Slight	Enough to be visible after some months	High-- probably due to oil, humidity or static	High
Examples	High-grade offices, not near production; laboratories; clean rooms	Offices in older buildings or near production; light assembly; inspection	Mill offices; paper processing; light machining	Heat treating; high speed printing; rubber processing	Similar to DIRTY but luminaires within immediate area of contamination

CLEANING-CYCLE

Time between luminaire cleanings, in years. The program calculates the light output from the luminaire after dirt has accumulated for a length of time equal to CLEANING-CYCLE.

Coefficient of Utilization

The next three keywords give the coefficient of utilization (CU) as a function of room cavity ratio (RCR), wall reflectance, and ceiling cavity reflectance (CCR)¹. Values of CU for these keywords can be obtained from luminaire manufacturers' photometric data sheets. All values here are for a floor cavity reflectance of 0.20. The program interpolates these values to get CU for a particular space geometry and surface reflectance, and makes a correction for floor reflectance other than 0.20.

CU-RCR-1

Takes a list of 9 values of CU for RCR = 1. The first set of 3 values corresponds to wall reflectances of 0.10, 0.30 and 0.50, respectively, and for a ceiling cavity reflectance of 0.30. The second set of 3 values corresponds the same wall reflectances, but for a ceiling cavity reflectance of 0.50. The third set of 3 values corresponds the same wall reflectances, but for a ceiling cavity reflectance of 0.80.

CU-RCR-5

Same as CU-RCR-1, but for RCR=5.

CU-RCR-10

Same as CU-RCR-1, but for RCR=10.

Example:

CU-RCR-1 = (0.28, 0.47, 0.60, 0.31, 0.52, 0.64, 0.37, 0.59, 0.73)

¹ Quoting from "Glossary of Lighting Terminology" in **Lighting Handbook, Reference & Application**, 8th Edition, Illuminating Engineering Society of North America:

Coefficient of Utilization (CU) is the ratio of luminous flux (lumens) from a luminaire calculated as received on the workplane to the luminous flux emitted by the luminaire's lamps alone. Room Cavity is the cavity formed by the plane of the luminaires, the workplane, and the wall surfaces between these two planes. Room Cavity Ratio (RCR) is a number indicating room cavity proportions, calculated from the length, width and height. Ceiling Cavity is the cavity formed by the ceiling, the plane of the luminaires and the wall surfaces between these two planes. Ceiling Cavity Ratio (CCR) is a number indicating ceiling cavity proportions calculated from length, width and height.

The average illuminance E on the workplane is given by

$$E = \# \text{ luminaires} / \text{Area} * \text{lamps/luminaire} * \text{lumens/lamp} * \text{CU} * \text{LLF}$$

Where LLF, the light-loss factor, accounts for dirt depreciation.

MATERIAL

Used to specify materials that are not in the Library (see *DOE-2.2 Libraries & Reports*, "Materials Library"). You must use either THICKNESS, CONDUCTIVITY, DENSITY, and SPECIFIC-HEAT or RESISTANCE. MATERIAL is used to specify the heat transfer properties for one layer of a construction. U-name must be used so that the MATERIAL may be referenced in a LAYERS command..

Example input:

```
BRICK-4IN = MATERIAL $ 4 inch brick
  TYPE           = PROPERTIES
  THICKNESS      = 0.333
  CONDUCTIVITY   = 0.4167
  DENSITY        = 120.0
  SPECIFIC-HEAT  = 0.2 ..

AIR-LAYER = MATERIAL $ 1 inch air layer
  TYPE           = RESISTANCE
  RESISTANCE     = 0.90 ..
```

TYPE

Takes a code-word that specifies the type of data to be provided.

PROPERTIES	indicates that the thickness and thermophysical properties of the material (conductivity, density, and specific heat) be input for this code-word unless the material is very lightweight or thin.
RESISTANCE	indicates that only the thermal resistance of the material will be input. Use this code-word only for very lightweight or thin materials.

TYPE=PROPERTIES

The following four keywords must be entered if TYPE=PROPERTIES:

THICKNESS

Thickness of the material layer

CONDUCTIVITY

Thermal conductivity of the material. The entry for this keyword is the conductance of a 1-ft (or 1-m) thick section of the material. Values given for 1-in (or 1-cm) thickness must be divided by 12 (or 100) to obtain the correct entry.

DENSITY

Density of the material

SPECIFIC-HEAT

Specific heat capacity of the material.

TYPE=RESISTANCE

The following keyword must be entered if TYPE=RESISTANCE:

RESISTANCE

The thermal resistance of the material.

POLYGON

The POLYGON command allows polygons with 3 to 30 sides to be described for exterior walls, interior walls and underground walls. It also allows the footprint of FLOORs and SPACEs to be described.

Format:

```

U-name = POLYGON
  V1           = (x1 , y1 )
  V2           = (x2 , y2 )
  V3           = (x3 , y3 )
  ...
  V30          = (x20 , y20) . .

```

The **U-name** is the user-assigned name of the polygon. It is referenced by the POLYGON keyword in EXTERIOR-WALL, INTERIOR-WALL, and UNDERGROUND-WALL, in which case the polygon defines the shape of the wall. It is referenced by the POLYGON keyword in SPACE, in which case it represents the floor (and ceiling) of the space. It is also referenced by the POLYGON keyword in FLOOR, where it represents the footprint of the floor.

V1 V2 V3 V4 V5 V6 V7 V8 V9
V10 V11 V12 V13 V14 V15 V16 V17 V18 V19
V20 V21 V22 V23 V24 V25 V26 V27 V28 V29
V30 V31 V32 V33 V34 V35 V36 V37 V38 V39
V40 V41 V42 V43 V44 V45 V46 V47 V48 V49
V50 V51 V52 V53 V54 V55 V56 V57 V58 V59
V60 V61 V62 V63 V64 V65 V66 V67 V68 V69
V70 V71 V72 V73 V74 V75 V76 V77 V78 V79
V80 V81 V82 V83 V84 V85 V86 V87 V88 V89
V90 V91 V92 V93 V94 V95 V96 V97 V98 V99
V100 V101 V102 V103 V104 V105 V106 V107 V108 V109
V110 V111 V112 V113 V114 V115 V116 V117 V118 V119
V120

are keywords denoting vertices 1 through 120 (from 3 to 120 vertices can be specified). (x_N,y_N) are the coordinates of the Nth vertex of the polygon.

The vertices are defined in an x-y coordinate system that is local to the polygon. This local coordinate system can then be positioned as follows:

1. It is positioned in the space coordinate system using X, Y, Z, AZIMUTH, and TILT for EXTERIOR-WALLs, INTERIOR-WALLs and UNDERGROUND-FLOORs for which the POLYGON keyword is specified.
2. It is positioned in the floor coordinate system using X, Y, Z and AZIMUTH for SPACEs for which the POLYGON keyword is specified.
3. It is positioned in the building coordinate system using X, Y, Z and AZIMUTH for FLOORs for which the POLYGON keyword is specified.

The vertices must be in counter-clockwise order when you are facing the polygon. The units of x_N and y_N are feet (for INPUT-UNITS=ENGLISH) or meters (for INPUT-UNITS=METRIC).

Example 1: This input describes the triangle shown in Figure 9.

```

TRIANG1 = POLYGON
V1           = ( 0 , 0 )
V2           = ( 80 , 0 )
V3           = ( 40 , 80 ) . .
    
```

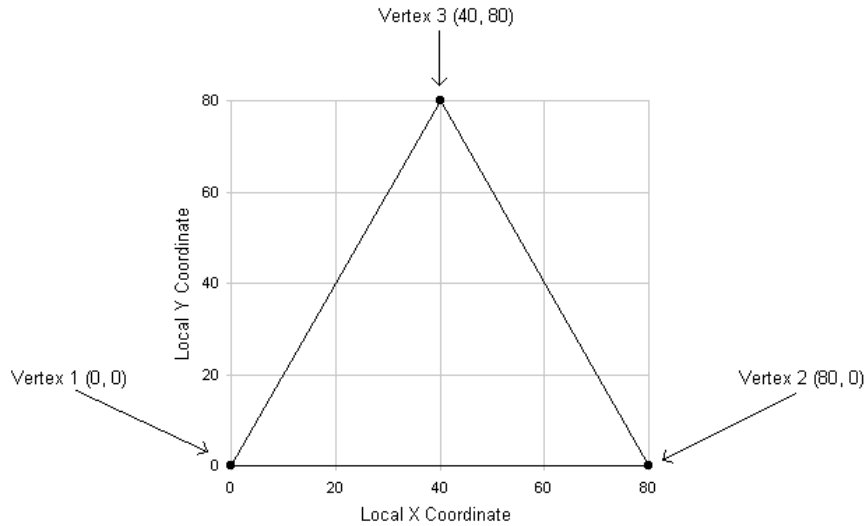

Figure 9 Example 1 Polygon
 (The polygon's first vertex is at the origin of the polygon's local coordinate system)

The first vertex does not have to be at the origin of the local coordinate system. This is shown in the next example. However, it is generally most convenient to place Vertex 1 at (0,0), as shown in Figure 9.

Example 2: This polygon's first vertex is displaced from the origin

```

TRIANG2 = POLYGON
V1           = ( 20 , 40 )
V2           = ( 50 , 40 )
V3           = ( 20 , 80 ) . .
    
```

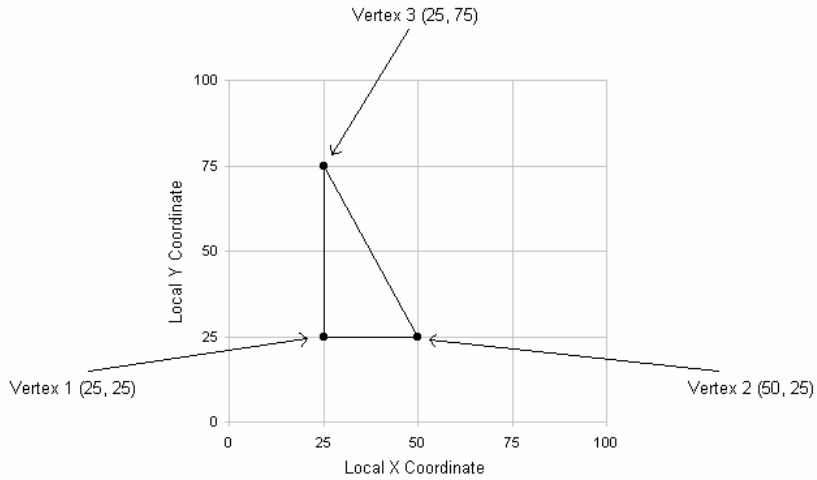

Figure 10 Example 2 polygon
(The polygon's first vertex is displaced from origin of the polygon's local coordinate system)

Polygons are allowed to be convex or concave, but the sides should not cross (see Figure 11). Also, two or more vertices should not be the same (i.e., have the same x,y values). Finally it is not possible to describe a polygon with a cutout in the middle, such as a doughnut.

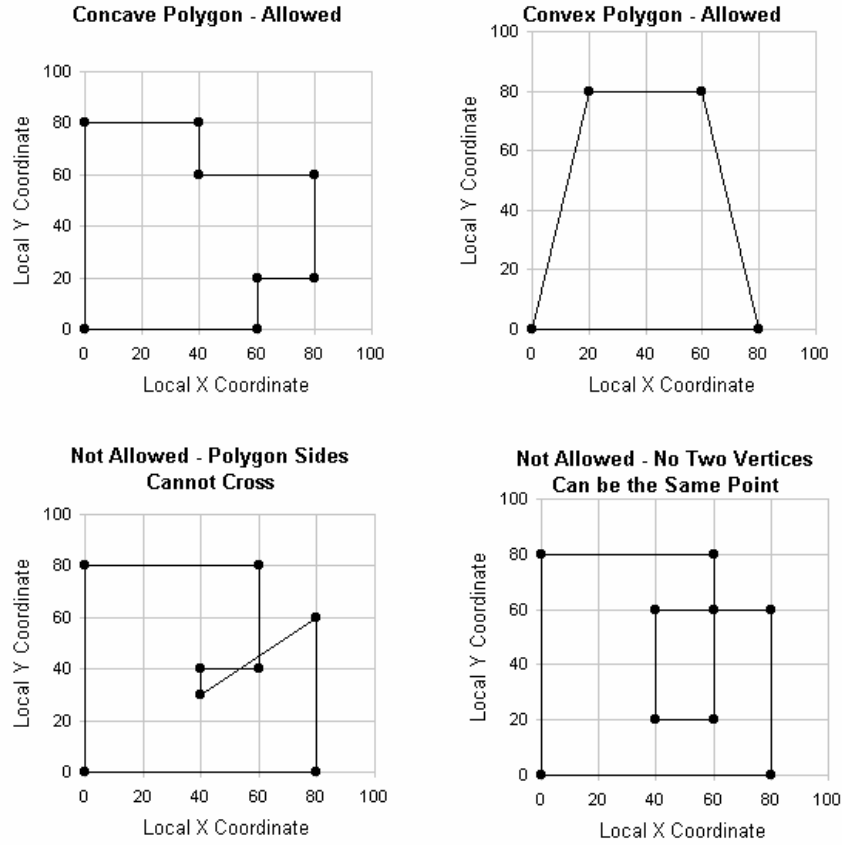

Figure 11 Example polygons
 (Both convex and concave polygons are allowed, but two vertices the same, or crossing sides, are not allowed)

To refer to a previously-defined polygon, you use POLYGON = U-name in the EXTERIOR-WALL, INTERIOR-WALL, UNDERGROUND-WALL, SPACE and FLOOR. X, Y, Z, AZIMUTH, and TILT can be used in these commands to position and orient the polygon in different coordinate systems. This is illustrated in Example 3 and Figure 12 for a wall polygon in the SPACE coordinate system.

Example 3 (see Figure 12):

```

TRIANG3 = POLYGON
  V1      = ( 0 , 0 )
  V2      = ( 20 , 0 )
  V3      = ( 10 , 20 ) . .

EW1 = EXTERIOR-WALL
  POLYGON      = TRIANG3
  X             = 8
  Y             = 3.5
  Z             = 6
  AZIMUTH      = 180
  TILT         = 90
  CONSTRUCTION = CONS1 . .
    
```

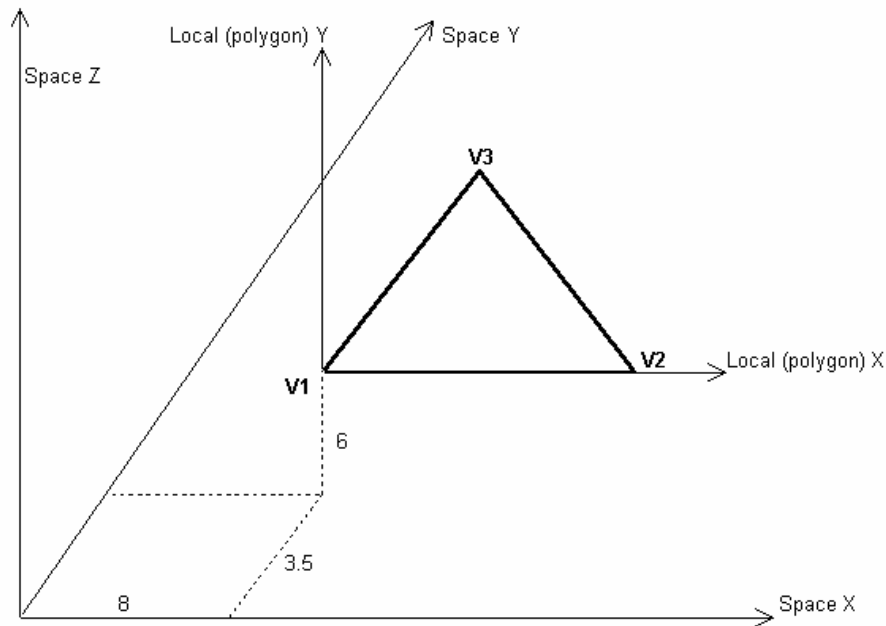

Figure 12 Example 3 triangular wall
 [The wall has a 90° tilt and 180° azimuth, located at X=8, Y=3.5, Z=6 in the space coordinate system. In the coordinate system local to the triangle, the vertex coordinates are V1= (0,0), V2= (20,0) and V3= (10,20)]

In this example:

X,Y,Z are the coordinates of the origin of the polygon's local coordinate system in the space coordinate system.

TILT is the angle between the Z-axis of the space coordinate system and the polygon outward normal, which is a vector, perpendicular to the plane of the polygon, that points toward you as you face the polygon (see Figure 12). (The polygon outward normal is also defined as the cross product between the vector from vertex 1 to vertex 2 and the vector from vertex 2 to vertex 3. It is also the cross product of the x and y axes of the polygon's local coordinate system.) A vertical polygon has TILT=90. A horizontal, upward-facing polygon (e.g., a horizontal roof) has TILT=0. A horizontal, downward-facing polygon (e.g., an exposed floor) has TILT=180.

AZIMUTH is the angle, measured clockwise, between the x-axis of the space coordinate system and the projection of the polygon outward normal onto the SPACE x-y plane.

Note that windows, doors and building shades continue to be rectangular only, as in previous versions of the program. They cannot be entered as polygons. However, windows and doors can be placed in polygonal walls and building shades can shade polygonal walls.

Figure 13 shows how to locate a window (or a door) on a polygonal wall. You position the window in the polygon's local coordinate system.

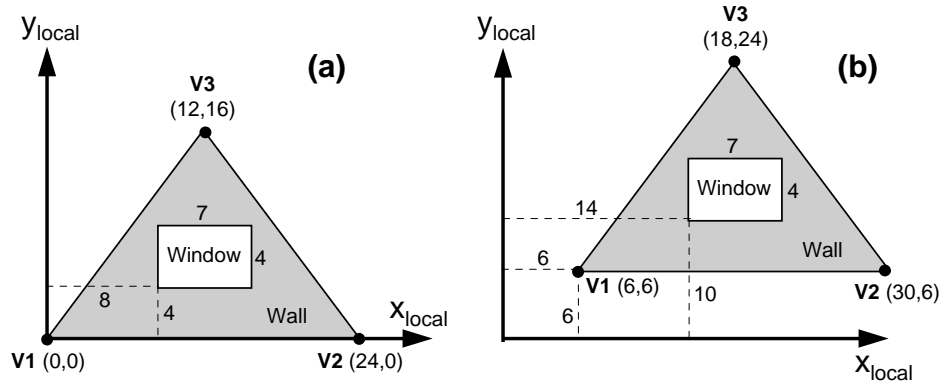

Figure 13 Locating a window or door in a polygonal wall.
 (The X and Y values of the lower left corner of the window are given in the polygon's local coordinate system. In (a), the first vertex of the polygon coincides with the origin of the local coordinate system. In (b), the first vertex of the polygon is displaced from the origin of the local coordinate system)

In case (a) we have chosen the origin of the local coordinate system to be at the first vertex of the polygon (i.e., $V1 = (0,0)$). The lower left hand corner of the window is at $X=8, Y=4$. Example input in this case is:

```

TRIANG4 = POLYGON
  V1           = ( 0 , 0 )
  V2           = ( 24 , 0 )
  V3           = ( 12 , 16 ) ..

EW2 = EXTERIOR-WALL
  POLYGON     = TRIANG4
  ...

WIN1 = WINDOW
  X           = 8
  Y           = 4
  HEIGHT      = 4
  WIDTH       = 7
  ...
    
```

In case (b), $V1=(6,6)$ so that the polygon is displaced in its local coordinate system. The lower left hand corner of the window is at $X=14, Y=10$. Example input in this case is:

```

TRIANG4 = POLYGON
  V1           = ( 6 , 6 )
  V2           = ( 30 , 6 )
  V3           = ( 18 , 24 ) ..

EW2 = EXTERIOR-WALL
  POLYGON     = TRIANG4
  ...

WIN1 = WINDOW
  X           = 14
  Y           = 10
  HEIGHT      = 4
    
```

WIDTH = 7

To avoid confusion, we recommend that you always choose $V1 = (0,0)$, as in case (a). This means that when you locate the window it is with respect to this vertex of the polygon.

Verification report (LV-N) lists all the exterior walls, interior walls, and windows with their vertex coordinates in the building coordinate system.

SITE-PARAMETERS

Specifies information about the building site.

Example input: The data entry below describes the site for a building in Los Alamos, New Mexico. Daylight savings time is in effect

```
SITE-PARAMETERS
LATITUDE           = 35.8
LONGITUDE          = 106.3
ALTITUDE           = 7200
TIME-ZONE          = 7
DAYLIGHT-SAVINGS  = YES
GROUND-T           = (45,45,45,50,50,55,55,55,55,50,50,45)
CLEARNESS-NUMBER  = (1.05,1.05,1.08,1.10,1.13,1.15,
                    1.15,1.15,1.13,1.10,1.08,1.05) ..
```

LATITUDE

Angular distance in degrees from the plane of the equator to the origin of the building coordinate system. Latitudes in the Northern hemisphere are specified in positive degrees, and in the Southern hemisphere in negative degrees. If not specified, this value will be taken from the weather file.

LONGITUDE

Angular distance in degrees from the prime (Greenwich) meridian to the origin of the building coordinate system. Longitudes west of Greenwich are positive, east of Greenwich are negative. If not specified, this value will be taken from the weather file.

ALTITUDE

Distance of the origin of the building coordinate system above (positive) or below (negative) mean sea level. If you want to input air flow rates instead of having the program adjust them for altitude, ALTITUDE should be set to zero. If not specified, this value will be taken from the weather file.

TIME-ZONE

Specifies the time zone for a building relative to Greenwich as time zone 0. The values range from -1 to -12 for zones east of the prime meridian and from 1 to 12 for zones west of the prime meridian. If not specified, this value will be taken from the weather file. The TIME-ZONE values for the United States are:

4-Atlantic	7-Mountain
5-Eastern	8-Pacific
6-Central	9-Yukon
	10-Hawaii

DAYLIGHT-SAVINGS

Accepts a code-word specifying whether daylight savings time is used. When daylight savings is in effect it means that one 23-hour day occurs in the spring, and one 25-hour day occurs in the fall. The building schedules are adjusted accordingly with respect to solar noon. In the program, the clock time is moved forward on the first Sunday of April, and back again the last Sunday of October.

YES	Daylight savings is in effect
NO	Disables daylight savings.

GROUND-T

Takes a list of 12 local mean ground temperatures, one for each month. If not specified, the monthly values will be taken from the weather file.

CLEARNESS-NUMBER

Takes a list of twelve local monthly clearness-numbers for each month of the year (see ASHRAE Trans., Vol. 64, p. 67). These apply when the clearness numbers on the weather file being used are not appropriate.. If not specified, the monthly values will be taken from the weather file.

Wind Speed Modification Keywords

The following six keywords are used to obtain the local, free stream wind speed at the building from the wind speed measured at the weather station. These keywords are modification factors that account for the effect of terrain and obstructions at the weather station and at the building. The program also modifies the local wind speed according to the height of a space, given by the SPACE Z value. The local wind speed is used by the program to calculate wind speed-dependent infiltration rates and outside air film coefficients. You can print the local wind speed as LOADS hourly report variable #58 for VARIABLE-TYPE = U-name of space, and the weather file wind speed as LOADS hourly report variable #17 for VARIABLE-TYPE=GLOBAL (see "Hourly Reports," in the *DOE-2.2 Libraries & Reports*).

SHIELDING-COEF

Modifies the local wind speed to account for changes in the wind pressure caused by local obstructions. A value should be selected from Table 17.

Table 17 SHIELDING-COEF Values

Description	SHIELDING-COEF
No obstructions or local shielding whatsoever, e.g., desert.	0.32
Light local shielding with some obstructions (a few trees, small shed).	0.29
Moderate local shielding, some obstructions within two house heights, a thick hedge or a solid fence, or one neighboring house	0.24 (default)
Heavy shielding, obstructions around most of perimeter, buildings or trees within 30 feet (10 meters) in most directions, typical suburban shielding.	0.19
Very heavy shielding, large obstructions surrounding perimeter within two house heights, typical downtown shielding.	0.10

TERRAIN-PAR1, TERRAIN-PAR2

Used to modify the local free stream wind speed to account for ground roughness and height above ground level at the building site. Select values from Table 18.

Table 18 Terrain parameters

Description	TERRAIN-PAR1 WS-TERRAIN- PAR1	TERRAIN-PAR2 WS-TERRAIN- PAR2
Ocean or other body of water with at least 5km of unrestricted expanse.	1.30	0.10
Flat terrain with some isolated obstacles, e.g., buildings or trees well separated from each other	1.00	0.15
Rural area with low buildings, trees, etc.	0.85	0.20
Urban, industrial, or forest area.	0.67	0.25
Center of a big city (Manhattan).	0.47	0.35

WS-TERRAIN-PAR1, WS-TERRAIN-PAR2

Used to modify the local free stream wind speed to account for ground roughness at the weather station. The default values correspond to a flat terrain with isolated obstacles, which is typical of weather stations at airports.

If the weather station is at the building site, set TERRAIN-PAR1=WS-TERRAIN-PAR1 and TERRAIN-PAR2=WS-TERRAIN-PAR2 (since no correction is needed for differences in terrain between weather station and building).

WS-HEIGHT

Height above ground level at which the wind speed measurement was made.

ATM-MOISTURE

This keyword is used in the daylighting calculation to determine exterior daylight availability. It should be entered only if both of the following are true:

1. At least one space has DAYLIGHTING=YES, and
2. The weather file does not have measured solar radiation. This keyword is not required for weather files that do have measured solar radiation (such as TMY, TMY2, WYEC and WYEC2).

When using daylighting, takes a list of 12 monthly values, in inches, of precipitable water in the atmosphere. Table 20 shows values for selected U.S. locations. If a similar climate cannot be found in Table 20 values can be assigned as listed in Table 19.

Table 19 Yearly Average Atmospheric Moisture for U.S. Regions

Climate Type	Atmospheric Moisture (in.)
Desert (dry air)	0.4
Temperate	0.7 (default)
Tropical (humid air)	1.3

Table 20

Monthly Average Atmospheric Moisture (inches of water) for U.S. Cities

City	Month											
	J	F	M	A	M	J	J	A	S	O	N	D
Montgomery, AL	.65	.56	.65	.85	1.00	1.31	1.58	1.60	1.39	.95	.67	.69
Ft. Smith, AR	.48	.47	.56	.78	1.08	1.39	1.66	1.56	1.16	1.03	.53	.48
Little Rock, AR	.51	.46	.55	.81	.94	1.26	1.47	1.42	1.29	.86	.63	.59
Ft. Huachuca, AZ	.27	.27	.24	.26	.36	.59	1.01	1.01	.73	.48	.31	.27
Phoenix, AZ	.42	.38	.38	.45	.51	.67	1.29	1.31	.92	.63	.43	.40
China Lake, CA	.28	.25	.28	.34	.38	.40	.66	.68	.47	.33	.29	.32
Oakland, CA	.52	.49	.48	.45	.53	.63	.64	.67	.64	.59	.61	.50
Point Mugu, CA	.46	.45	.48	.51	.65	.79	1.04	.97	.89	.69	.54	.49
San Diego, CA	.46	.46	.47	.50	.60	.71	.98	1.04	.83	.62	.60	.48
San Nicolas Is., CA	.47	.42	.43	.42	.52	.65	.85	.80	.73	.61	.53	.46
Santa Maria, CA	.48	.48	.48	.52	.61	.68	.82	.80	.74	.63	.55	.49
Santa Monica, CA	.48	.51	.49	.56	.65	.75	.93	.95	.85	.72	.54	.50
Denver, CO	.20	.19	.21	.27	.41	.57	.75	.71	.51	.35	.25	.20
Grand Junction, CO	.25	.24	.24	.28	.39	.51	.73	.72	.52	.41	.31	.26
Cocoa Beach, FL	.86	.85	.95	1.03	1.26	1.60	1.73	1.79	1.76	1.37	1.02	.90
Key West, FL	1.04	1.03	1.06	1.13	1.34	1.65	1.64	1.71	1.78	1.53	1.20	1.05
Miami, FL	.96	.95	1.00	1.10	1.31	1.64	1.69	1.74	1.77	1.50	1.18	1.10
Atlanta, GA	.54	.52	.56	.72	.95	1.26	1.48	1.45	1.20	.83	.59	.54
Boise, ID	.35	.32	.30	.34	.44	.59	.60	.60	.52	.42	.40	.32
Joliet, IL	.36	.32	.40	.53	.76	1.11	1.21	1.12	.88	.66	.43	.35
Peoria, IL	.30	.31	.37	.55	.76	1.02	1.17	1.13	.96	.65	.46	.36
Salem, IL	.31	.35	.41	.57	.72	1.09	1.19	1.19	1.12	.74	.46	.42
Dodge City, KS	.28	.27	.30	.42	.61	.86	1.09	1.04	.81	.53	.37	.30
Boothville, LA	.82	.72	.78	1.00	1.13	1.41	1.69	1.72	1.60	1.17	.87	.94
Lake Charles, LA	.74	.72	.77	.95	1.17	1.45	1.70	1.67	1.50	1.05	.83	.78
Nantucket, MA	.38	.36	.40	.53	.73	.97	1.15	1.26	.95	.71	.56	.42
Caribou, ME	.23	.22	.26	.36	.55	.79	.95	.90	.74	.55	.40	.27
Portland, ME	.30	.29	.33	.46	.66	.93	1.08	1.05	.87	.63	.49	.34
Flint, MI	.27	.26	.31	.46	.64	.89	.99	.97	.86	.61	.43	.33
Sault Ste. Marie, MI	.23	.22	.27	.39	.57	.83	.92	.93	.78	.58	.39	.28
Int'l Falls, MN	.19	.19	.23	.35	.52	.77	.90	.87	.68	.49	.30	.22
St. Cloud, MN	.22	.23	.27	.42	.63	.86	1.00	.99	.77	.56	.34	.26
Columbia, MO	.36	.32	.42	.62	.78	1.10	1.23	1.21	.98	.70	.52	.42
Jackson, MS	.59	.60	.65	.87	1.05	1.36	1.59	1.56	1.36	.92	.71	.65
Glasgow, MT	.23	.24	.25	.34	.49	.68	.77	.73	.57	.42	.31	.25
Great Falls, MT	.23	.22	.23	.27	.39	.54	.58	.58	.46	.34	.28	.23
North Platte, NB	.26	.28	.30	.41	.62	.85	1.02	.99	.72	.49	.33	.28
Omaha, NB	.28	.29	.35	.50	.74	1.03	1.18	1.13	.87	.62	.40	.31
Cape Hatteras, NC	.59	.52	.56	.70	.96	1.20	1.57	1.57	1.25	.97	.67	.63
Greensboro, NC	.47	.45	.50	.65	.90	1.18	1.39	1.37	1.11	.77	.55	.47

Monthly Average Atmospheric Moisture (inches of water) for U.S. Cities

City	Month											
	J	F	M	A	M	J	J	A	S	O	N	D
Bismark, ND	.22	.24	.26	.38	.56	.81	.93	.88	.65	.47	.31	.25
Rapid City, ND	.26	.26	.28	.37	.53	.75	.87	.81	.59	.42	.30	.26
Ely, NV	.21	.20	.20	.22	.31	.42	.54	.57	.38	.29	.26	.21
Albuquerque, NM	.21	.20	.21	.24	.33	.47	.80	.79	.58	.38	.27	.22
Albany, NY	.30	.28	.35	.48	.70	.98	1.11	1.10	.93	.65	.49	.36
Buffalo, NY	.30	.29	.34	.47	.66	.91	1.04	1.02	.87	.63	.46	.35
New York City, NY	.34	.33	.40	.54	.76	1.02	1.18	1.16	1.01	.69	.55	.42
Dayton, OH	.33	.33	.39	.56	.74	1.00	1.13	1.08	.93	.65	.47	.38
Medford, OR	.46	.42	.40	.41	.51	.65	.67	.67	.59	.52	.53	.43
Salem, OR	.52	.48	.45	.47	.56	.71	.73	.76	.70	.62	.60	.51
Pittsburgh, PA	.34	.32	.38	.52	.72	.97	1.09	1.06	.90	.63	.47	.37
Charleston, SC	.65	.63	.68	.83	1.11	1.42	1.67	1.66	1.43	1.02	.75	.66
Nashville, TN	.45	.41	.49	.70	.85	1.13	1.33	1.31	1.19	.77	.55	.53
Amarillo, TX	.28	.26	.30	.39	.55	.80	1.03	1.00	.80	.52	.37	.30
Brownsville, TX	.90	.90	.94	1.12	1.31	1.48	1.57	1.60	1.64	1.31	1.07	.96
Midland, TX	.34	.33	.37	.48	.65	.89	1.06	1.10	.97	.64	.44	.36
El Paso, TX	.29	.28	.30	.33	.44	.67	.98	1.00	.83	.52	.37	.32
Ft. Worth, TX	.48	.51	.58	.80	1.06	1.32	1.48	1.46	1.28	.90	.65	.54
Salt Lake City, UT	.29	.26	.25	.30	.40	.54	.66	.66	.50	.38	.34	.27
Quillayute - Tatoosh Is., WA	.46	.47	.44	.48	.57	.71	.77	.82	.75	.67	.55	.50
Green Bay, WI	.23	.23	.28	.44	.63	.89	1.02	.99	.82	.60	.39	.28
Huntington, WV	.39	.37	.47	.62	.82	1.08	1.25	1.19	1.04	.72	.53	.45
Lander, WY	.18	.17	.18	.24	.33	.47	.54	.53	.40	.29	.23	.18

Source: A.Lott, "Precipitable Water Over the United States, Volume 1: Monthly Means", NOAA Technical Report NWS 20, November 1976.

ATM-TURBIDITY

This keyword is used in the daylighting calculation to determine exterior daylight availability. It should be entered only if both of the following are true:

1. At least one space has DAYLIGHTING=YES, and
2. The weather file does not have measured solar radiation. This keyword is not required for weather files that do have measured solar radiation (such as TMY, TMY2, WYEC and WYEC2).

When using daylighting, takes a list of 12 monthly values of atmospheric turbidity (a measure of the amount of particulate pollutants in the atmosphere). Table 21 shows values for selected U.S. locations. If a similar climate cannot be found in Table 21 values can be assigned as listed in Table 22.

Table 21 Yearly Average Atmospheric Moisture for U.S. Regions

City	Src ²	J	F	M	A	M	J	J	A	S	O	N	D
Eielson AFB, AL	2	.03	.03	.11	.11	.20	.07	.09	.12	.07	.04	.04	.04
Little Rock, AR	2	.11	.16	.17	.22	.22	.20	.22	.20	.19	.13	.10	.09
Phoenix, AZ	3	.05	.06	.07	.08	.08	.08	.08	.07	.07	.06	.07	.07
Tucson, AZ	1	.05	.05	.06	.07	.07	.07	.07	.07	.07	.06	.06	.07
Edwards AFB, CA	2	.02	.02	.06	.09	.09	.08	.08	.08	.07	.06	.04	.04
Fresno, CA	3	.06	.08	.08	.05	.11	.06	.06	.05	.08	.07	.05	.03
Los Angeles, CA	1	.11	.14	.15	.16	.18	.21	.20	.21	.19	.17	.11	.11
Santa Maria, CA	3	.09	.13	.16	.19	.23	.20	.17	.18	.22	.20	.15	.09
Alamosa, CO	2	.09	.11	.12	.15	.13	.10	.10	.06	.07	.07	.07	.07
Boulder, CO	1	.04	.05	.07	.09	.08	.07	.07	.07	.07	.05	.05	.04
Washington, DC	3	.12	.14	.16	.18	.20	.22	.24	.21	.18	.16	.13	.14
Appalachicola, FL	3	.13	.14	.16	.21	.24	.24	.23	.24	.25	.19	.20	.14
Cape Canaveral, FL	4	.10	.11	.13	.13	.19	.20	.17	.17	.19	.17	.11	.10
Gainesville,	4	.08	.08	.10	.14	.14	.17	.21	.21	.22	.13	.08	.06
Miami, FL	4	.11	.14	.15	.20	.21	.21	.21	.20	.18	.17	.14	.12
Tallahassee, FL	4	.09	.11	.11	.14	.18	.22	.25	.22	.20	.10	.07	.07
Dodge City, KA	3	.03	.04	.04	.06	.08	.07	.09	.09	.08	.04	.03	.04
Lake Charles, LA	3	.13	.14	.16	.21	.24	.24	.23	.24	.25	.19	.20	.14
Idaho Falls, ID	1	.03	.04	.06	.07	.07	.07	.06	.06	.06	.05	.04	.03
Chicago, IL	1	.15	.18	.21	.18	.18	.19	.22	.16	.16	.14	.13	.15
Salem, IL	2	.09	.10	.16	.17	.21	.22	.23	.21	.17	.16	.10	.09
Blue Hill, MA	1	.07	.07	.09	.11	.13	.16	.17	.13	.08	.07	.07	.06
Boston, MA	3	.09	.10	.13	.16	.18	.17	.18	.17	.11	.11	.08	.07
Baltimore, MD	1	.12	.18	.18	.19	.22	.27	.31	.32	.31	.12	.17	.18
College Park, MD	2	.07	.08	.13	.17	.23	.21	.13	.23	.17	.13	.08	.07
Caribou, ME	3	.05	.06	.05	.08	.07	.08	.09	.08	.05	.05	.03	.05
Great Falls, MN	3	.05	.06	.07	.08	.08	.07	.07	.07	.07	.06	.06	.05
St. Cloud, MN	2	.08	.06	.08	.13	.11	.09	.11	.10	.08	.06	.05	.05
Columbia, MO	3	.04	.05	.05	.07	.09	.09	.09	.09	.08	.04	.03	.04
St. Louis, MO	1	.12	.12	.16	.17	.21	.20	.22	.19	.19	.12	.12	.11
Meridian, MS	1	.07	.07	.07	.09	.12	.15	.15	.13	.11	.07	.07	.07
Missoula, MT	1	.06	.07	.07	.08	.09	.07	.07	.06	.09	.08	.07	.07

² * Source:

1. Flowers, R. A. McCormick, and K. R. Kurfis, Atmospheric Turbidity over the United States, 1961-66, Journal of Applied Meteorology, Vol. 8, No. 6, 1969, pp. 955-962.
2. Global Monitoring of the Environment for Selected Atmospheric Constituents, 1977, Environmental Data and Information Service, National Climatic Center, Asheville, NC, June 1980.
3. SOLMET Vol. 2, Hourly Solar Radiation Surface Meteorological Observations , Final Report TD-9724, National Climatic Center, Asheville, NC, June 1979, as quoted in M. Iqbal, AN INTRODUCTION TO SOLAR RADIATION , Academic press, 1983, p.120.
4. Gueymard, C. and McCluney, R.M., The Average Beam, Global Horizontal and Global Normal Radiation, Sunshine Probability and Turbidity at Cape Canaveral, FL, Proc. Solar 92 The National Solar Energy Conference, Cocoa Beach, FL, 1992.

City	Src ²	J	F	M	A	M	J	J	A	S	O	N	D
N. Omaha, NB	3	.04	.05	.05	.07	.09	.09	.09	.09	.08	.04	.03	.04
Cape Hatteras, NC	3	.06	.08	.09	.12	.15	.17	.24	.25	.21	.09	.07	.05
Greensboro, NC	1	.07	.08	.09	.11	.14	.24	.22	.21	.14	.08	.07	.07
Raleigh, NC	3	.07	.08	.10	.13	.15	.25	.23	.23	.17	.10	.09	.07
Bismark, ND	3	.05	.07	.12	.13	.12	.11	.12	.11	.07	.06	.03	.03
Ely, NE	3	.05	.06	.07	.08	.08	.08	.08	.07	.07	.06	.07	.07
Albuquerque, NM	3	.03	.04	.04	.06	.05	.04	.04	.05	.03	.03	.02	.02
Albany, NY	1	.10	.09	.11	.12	.14	.14	.15	.15	.14	.11	.10	.09
Brookhaven, NY	1	.07	.07	.10	.11	.12	.14	.15	.11	.12	.07	.07	.07
New York, NY	3	.10	.10	.14	.15	.17	.18	.22	.20	.16	.14	.10	.08
Cincinnati, OH	1	.07	.09	.12	.13	.14	.20	.20	.19	.17	.12	.10	.08
Toledo, OH	2	.09	.08	.12	.11	.15	.13	.15	.11	.09	.05	.06	.06
Youngstown, OH	2	.14	.14	.16	.19	.25	.29	.22	.28	.22	.17	.15	.13
Medford, OR	3	.09	.13	.16	.19	.23	.20	.17	.18	.22	.20	.15	.09
Pendleton, OR	2	.10	.12	.16	.20	.19	.19	.16	.15	.11	.09	.09	.09
Philadelphia, PA	1	.12	.15	.18	.20	.22	.25	.27	.23	.17	.15	.14	.14
Charleston, SC	3	.06	.08	.09	.12	.15	.17	.24	.25	.21	.09	.07	.05
Huron, SD	1	.04	.05	.07	.07	.08	.09	.08	.07	.07	.06	.05	.04
Memphis, TN	1	.08	.08	.10	.16	.15	.18	.19	.16	.16	.09	.10	.08
Nashville, TN	3	.09	.11	.13	.15	.17	.20	.19	.17	.15	.13	.11	.09
Oak Ridge, TN	2	.10	.14	.13	.17	.33	.26	.37	.31	.25	.13	.09	.09
Brownsville, TX	3	.05	.06	.07	.08	.08	.08	.08	.07	.07	.06	.07	.07
College Stn., TX	1	.10	.10	.11	.12	.13	.08	.15	.12	.11	.09	.08	.07
El Paso, TX	3	.05	.06	.07	.08	.08	.08	.08	.07	.07	.06	.07	.07
Ft. Worth, TX	3	.04	.08	.09	.12	.12	.13	.13	.19	.14	.08	.04	.04
Grand Prarie, TX	2	.07	.12	.16	.16	.36	.35	.36	.53	.45	.23	.19	.21
Victoria, TX	2	.03	.03	.05	.02	.08	.08	.06	.05	.04	.04	.03	.02
Seattle, WA	3	.09	.13	.16	.19	.23	.20	.17	.18	.22	.20	.15	.09
Green Bay, WI	2	.09	.09	.15	.16	.19	.17	.16	.10	.09	.10	.05	.06
Madison, WI	3	.05	.06	.07	.10	.13	.11	.11	.12	.08	.07	.07	.05
Elkins, WV	1	.07	.07	.09	.14	.15	.21	.21	.19	.14	.07	.07	.07

This table contains values for the Angstrom turbidity coefficient (β)

Table 22
Yearly Average Atmospheric Turbidity for U.S. Regions

Category	Atmospheric Turbidity
Rural Area	0.07
Urban Area	0.12 (default)
Industrial Area	0.16

Notes

- One, and only one, SITE-PARAMETERS instruction must be entered for each separate program run. It should be input before any commands that describe the building or anything associated with it (e.g., SPACE or CONSTRUCTION).

2. If GROUND-T and CLEARNESS-NUMBER are not input, the values will be taken from the weather file.
3. If LONGITUDE, LATITUDE, or TIME-ZONE are not specified, the values will be taken from the weather file.
4. The effect of terrain on the wind speed at the building is described with the keywords TERRAIN-PAR1, TERRAIN-PAR2, etc.

SPACE

Provides information associated with a space. U-name must be used to identify the space so that it can be referenced in SYSTEMS input. LIKE may be used to copy data from a previously U-named SPACE instruction. LIKE only copies the SPACE instruction and does not carry with it walls, roof, or floors.

Example input:

An 8-ft high space with a floor area of 800 ft² is located 15 ft east along the south wall of a building aligned in a N-S direction. The overhead lighting is fluorescent (2W/ft²) with some task lighting (300W). There is a 1-hp motor (1 hp = 0.745 kW) in the space running at 80 percent efficiency (thus 20 percent of its energy consumption shows up as heat added to the space). Infiltration is 2 air changes per hour, and six people occupy the space. The space is conditioned.

```
OFFICE = SPACE
X           = 15 .
Y           = 0 .
AZIMUTH    = 0 .
AREA       = 800 .
VOLUME     = 6400 .
PEOPLE-SCHEDULE = MANHR-1
NUMBER-OF-PEOPLE = 6
PEOPLE-HG-LAT = 200
PEOPLE-HG-SENS = 250
LIGHTING-SCHEDULE = HILITE
LIGHTING-TYPE = SUS-FLUOR
LIGHTING-W/AREA = 2
LIGHT-TO-SPACE = 1.0
TASK-LIGHT-SCHED = LOLITE-1
TASK-LIGHTING-KW = 0.3
EQUIP-SCHEDULE = MOTOR-1
EQUIPMENT-KW = 0.75
EQUIP-SENSIBLE = 0.2
INF-METHOD = AIR-CHANGE
AIR-CHANGES/HR = 2 .
ZONE-TYPE = CONDITIONED . .
```

General

Before specifying the input data for SPACE, you should understand some of the logic built into the program. All of the heat sources associated with a particular space do not necessarily affect the heating and cooling loads of that space. Some sources contribute all of their heat to the space and others only part of their heat.

The heat that does not enter the space is consumed by a product or process, is added to the return air duct or plenum, or is exhausted from the space. You control the fraction of heat that enters the space with the LIGHT-TO-SPACE keyword for overhead lighting and the sensible and latent keywords for process loads.

That portion of the heat that does not enter the space has no effect upon the subsequent sizing of HVAC equipment. The corresponding energy demand is, however, added to the demands made on the equipment, or purchased utilities, in the primary systems simulator. It is not charged to the secondary HVAC system.

When the program sizes equipment in the primary systems simulator, it adds all of the space heating/cooling loads, all of the space process loads, and the building-level utility loads (elevators, exterior lighting, and domestic hot water) and then sizes the equipment accordingly to meet the total. This way, the total utility demands for the building will

be correct and the secondary HVAC system will not be charged with energy that rightfully belongs to the process in the building. Only that portion of the process load that enters the spaces as a heating/cooling load will show up in the secondary HVAC system.

It is important that all of the lighting, equipment, and utilities supplied to a space, for whatever reason, be included in the SPACE instruction. This includes process equipment and process utilities. If any loads are omitted, the secondary HVAC equipment may be properly sized but the primary equipment will probably be undersized. Do not, however, include the HVAC equipment items (fans, coils, etc.) because they are addressed separately by the program. Also, do not include building level loads such as domestic hot water, elevators, etc. because these loads are not associated with any particular space but rather are associated with the entire building.

You should pay close attention when specifying SCHEDULEs. All the SCHEDULEs associated with the SPACE, except INF-SCHEDULE, default to the off mode of operation. This means that even though the maximum output of the equipment, lights, etc. has been specified, the equipment and lights will not be turned on, unless you specify this mode of operation in the SCHEDULEs. Naturally, if you fail to turn the equipment and lights on, the simulation will be faulty.

U-name must be specified for this instruction in order for it to be referenced in the SPACE command. LIKE may be used to copy data from a previously U-named SPACE instruction.

ZONE-TYPE

Identifies whether the space is conditioned (i.e. heated and/or cooled), unconditioned, or a plenum. For LOADS calculations, a plenum is identical to unconditioned space. All SPACE keywords are allowed in CONDITIONED, UNCONDITIONED, and PLENUM spaces. The loads for an unconditioned space or a plenum will not appear in the building-level reports, LS-C, LS-D, and LS-F.

CONDITIONED	Space is heated and/or cooled.
UNCONDITIONED	Space is neither heated nor cooled.
PLENUM	Space is a return air plenum.

AREA

Floor area of the space. This keyword is required unless the SHAPE or POLYGON keywords are used.

VOLUME

Space air volume. This keyword is required unless the SHAPE or POLYGON keywords are used.

TEMPERATURE

The space air temperature used for the LOADS calculation. The value should be midway between the heating and cooling setpoints. It is best set equal to the design cooling temperature or design heating temperature, whichever will most probably be used to set the HVAC equipment size (air flow rate for air systems). For an unconditioned space, the TEMPERATURE value should be roughly equal to the average space temperature.

MULTIPLIER

Specifies the number of spaces that are identical to this SPACE. Use of this keyword reduces the amount of required data entry, but does not actually create other spaces. The program will calculate the loads for the space defined and multiply these loads by MULTIPLIER.

If a STANDARD or AIR type INTERIOR-WALL is defined in the space, the heat transfer to the NEXT-TO space is multiplied by MULTIPLIER. You must enter a wall area for INTERIOR-WALLs corresponding to that in the space being multiplied. Because it creates an ambiguity with regard to the area of the interior wall between them,

it is always an error for MULTIPLIER to be different from 1.0 in both of two adjacent spaces connected by STANDARD or AIR type INTERIOR-WALLs.

The MULTIPLIER or FLOOR-MULTIPLIER keywords in the SPACE command should be used only when the several spaces being modeled in this fashion are equivalent, with respect to thermodynamics and/or daylighting. Exterior shading, for example, must be the same for each of the spaces included. When there are adjacent spaces that are presumably identical, there should be negligible heat transfer between the spaces.

FLOOR-MULTIPLIER

Used to simplify the input for a multistory building. Equals the number of floors that are thermodynamically identical and where there is negligible heat transfer from floor to floor. FLOOR-MULTIPLIER multiplies space loads but does not multiply heat transfer through the SPACE's interior walls. The overall multiplier on the space load is (MULTIPLIER) x (FLOOR-MULTIPLIER).

Normally, you should allow this keyword to default to its parent FLOOR:MULTIPLIER.

SUNSPACE

If SUNSPACE=YES, this space is considered to be a sunspace, which allows the space to be directly vented with outside air to prevent overheating (see ZONE keywords SS-VENT-SCH, SS-VENT-T-SCH, etc.), and, if the space has INTERIOR-WALLs, allows the heat transfer across these walls into adjacent spaces by convection, delayed conduction, and solar transmission will be calculated. For more information, see "Sunspaces" in the *DOE-2.2 Topics*. Some rules about sunspaces are:

1. A building can have more than one sunspace. There can be more than one sunspace on a system.
2. INTERIOR-WALLs in a sunspace can have windows. The program calculates solar transmission through such interior windows.
3. A sunspace or a non-sunspace can have at most one INTERIOR-WALL with convective heat exchange (AIR-FLOW-TYPE = FORCED-RECIRC, FREE-RECIRC, OPEN-DOORWAY, or FORCED-OA-PREHT in the WALL-PARAMETERS command).
4. A sunspace and an adjacent non-sunspace can share several INTERIOR-WALLs (only one of which can have convective heat transfer). The conductive heat exchange is calculated separately for each INTERIOR-WALL.
5. Two sunspaces can be adjacent, but any windows in the common INTERIOR-WALL will be ignored, convective exchange across the wall will not be calculated, and the effect on the conduction through the wall due to absorbed solar radiation will not be considered.
6. A daylighting simulation can be done for a sunspace (by entering DAYLIGHTING = YES and setting daylighting related keywords), but the program cannot directly calculate daylight passing through interior windows from the sunspace to adjacent spaces.

Geometry

The following set of keywords define the geometry of a space.

SHAPE

Accepts a code-word defining the shape definition methodology:

- BOX** indicates that the SPACE is box-shaped. In this case, values must be given for the box dimensions HEIGHT, WIDTH, and DEPTH. AREA and VOLUME should not be entered. The advantage of using SHAPE=BOX is that the walls of the space can be easily positioned on the faces of the box by using LOCATION=TOP, LOCATION=RIGHT, etc. in the EXTERIOR-WALL, INTERIOR-WALL, and UNDERGROUND-WALL commands (see Figure 14).
- POLYGON** indicates that the shape of the space will be given by a polygon referenced with the POLYGON keyword. In this case, HEIGHT can be specified, but WIDTH, DEPTH, AREA and VOLUME should not be.
- NO-SHAPE** indicates that the space will not be defined as either a box or polygon. AREA and VOLUME must both be entered.

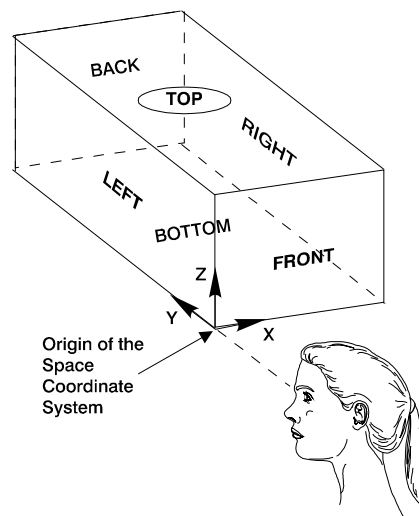

Figure 14 The faces of a BOX in the space coordinate system

HEIGHT

Height of the space. Used only when the SHAPE or POLYGON keywords are entered for the SPACE. The default is the height of the space's FLOOR. If entered, AREA and VOLUME should not be used.

WIDTH

Width of the space. Used only when SHAPE=BOX is specified, in which case it is the dimension of the box along its x-axis. If entered, AREA and VOLUME should not be used.

DEPTH

Depth of the space. Used only when SHAPE=BOX is specified, in which case it is the dimension of the box along its y-axis. If entered, AREA and VOLUME should not be used.

**X
Y
Z**

X, Y, and Z (Figure 15) give the location of the origin of the space coordinate system in the floor coordinate system. If SHAPE=BOX they give the location (in the floor coordinate system) of the lower left corner of the front of the

box when facing the box. If the POLYGON keyword is specified for this space, X, Y, and Z are the coordinates of the first vertex of the polygon (which represents the footprint of the space) floor coordinate system.

If this space is located by specifying the vertex of the space's floor's polygon, X, Y, and Z will default to the coordinates of the floor polygon. See "Geometry" in the *DOE-2.2 Topics*.

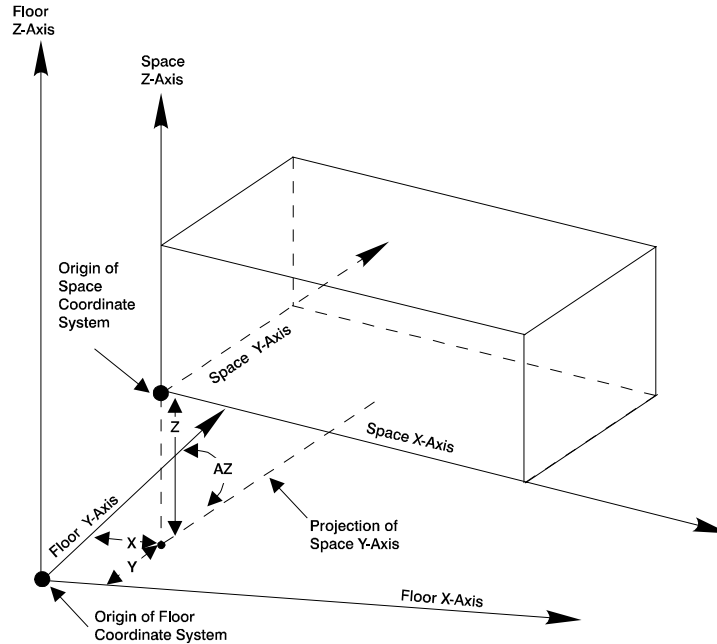

Figure 15 Positioning the origin of the space coordinate system.
(X, Y, and Z give the location of the origin of the space coordinate system in the floor)

AZIMUTH

Angle between the y-axis of the floor coordinate system and the y-axis of the space coordinate system Refer to Figure 15 and "Geometry" in the *DOE-2.2 Topics*.

POLYGON

Takes the U-name of a previously-entered POLYGON command. This polygon becomes the footprint of the space. The program extrudes this polygon by an amount equal to HEIGHT to obtain a 3-D volume (see Figure 16). Walls, floor, and ceiling can be positioned on the top, bottom, and side faces of this volume using LOCATION=TOP, BOTTOM, SPACE-V1, SPACE-V2, etc. in the EXTERIOR-WALL, INTERIOR-WALL, and UNDERGROUND-WALL commands.

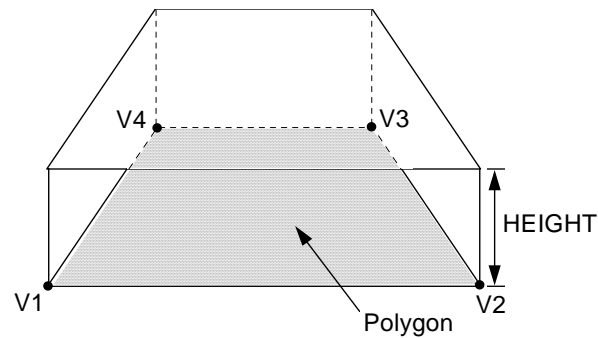

Figure 16 Space extrusion from a polygon

LOCATION

LOCATION provides an easy way of locating a space within a floor without having to use X,Y,Z and AZIMUTH. FLOOR-V1 positions the space with its origin at floor vertex 1 and with the space x-axis along the line running from floor vertex 1 to floor vertex 2. Similarly, FLOOR-V2 positions the space origin at floor vertex 2 with the space x-axis along the line from floor vertex 2 to floor vertex 3.

For quadrilateral floors, FRONT, BACK, RIGHT and LEFT can be used for clarity. FRONT is equivalent to FLOOR-V1, RIGHT to FLOOR-V2, BACK to FLOOR-V3, and LEFT to FLOOR-V4.

PLENUM-SPACE creates a space with the same area as the floor but located at SPACE-HEIGHT (specified in the FLOOR command) above the floor. FLOOR-SPACE just creates a space that occupies the entire floor.

Occupancy

The following set of keywords define the number of people present in a space, their sensible and latent heat gain, and their occupancy patterns

PEOPLE-SCHEDULE

Takes the U-name of a schedule (with TYPE=MULTIPLIER) for space occupancy as a function of time. Schedule inputs are fractions of maximum occupancy (as determined by NUMBER-OF-PEOPLE or AREA/PERSON). If PEOPLE-SCHEDULE is not entered the schedule value will default to zero and the space will be simulated with no people.

NUMBER-OF-PEOPLE

Maximum number of people occupying a space during the run period. The actual number of people present in the space during any given hour is the value assigned to this keyword, multiplied by the fractional value for that hour as given by PEOPLE-SCHEDULE. The number of people times the heat gain per person (see PEOPLE-HEAT-GAIN, PEOPLE-HG-LAT and PEOPLE-HG-SENS) determines the hourly sensible and latent heat gain from occupants.

PEOPLE-HEAT-GAIN

The maximum combined latent and sensible heat gain per person to the space. Table 23 gives typical values for different activity levels. The program calculates the split between sensible and latent components using a fixed air temperature of 75F (23.9C). The program determines the hourly heat gain from occupants from PEOPLE-HEAT-GAIN, PEOPLE-SCHEDULE and NUMBER-OF-PEOPLE or AREA/PERSON. Because the default is zero, a value must be input.

Table 23 PEOPLE-HEAT-GAIN Values for Different Activity Levels^a

Degree of Activity	Typical Application	PEOPLE-HEAT-GAIN ^b	
		Btu/hr	W
Seated at Theater	Theater	350	103
Seated/Very Light Work	Offices, Motels, Apts	400	117
Moderately Active Office Work	Offices, Hotels, Apts	450	132
Standing, Light Work, Walking	Department/Retail Store	450	132
Walking, Standing	Drugstore, Bank	500	147
Sedentary Work	Restaurant	550	161
Light Bench Work	Factory	750	220
Light Machine Work	Factory	1000	293
Heavy Work	Factory	1450	425
Athletics	Gymnasium	1800	527
^a From 1997 ASHRAE Handbook of Fundamentals, Table 3, Chapter 28			
^b Based on a normal percentage of men, women, and children for the application listed			

PEOPLE-HG-LAT

Along with PEOPLE-HG-SENS, an alternative to setting PEOPLE-HEAT-GAIN. The latent and sensible heat gain components can be specified by the user, rather than letting the program calculate the split.

PEOPLE-HG-SENS

Along with PEOPLE-HG-LAT, an alternative to setting PEOPLE-HEAT-GAIN. The latent and sensible heat gain components can be specified by the user, rather than letting the program calculate the split.

AREA/PERSON

An alternative to specifying number of people. The program calculates the number-of-people by dividing the space area by this keyword. A typical value for offices is 100 ft² per person.

Overhead Lighting

The following set of keywords define the characteristics of the lighting system.

LTG-SPEC-METHOD

Takes a code-word that determines how the overhead electric lighting is to be described.

POWER-DEFINITION You specify the installed lighting power or installed lighting power density, and associated lighting schedule. In this case, the lighting electrical consumption is calculated each hour by multiplying the installed lighting power by the lighting schedule value. The electric lighting illuminance is not calculated. For more details on this method, see the description of the LIGHTING-KW, LIGHTING-W/AREA and LIGHTING-TYPE keywords in the SPACE command.

LUMINAIRE-COUNT You specify lamp type, luminaire type and number of luminaires, and associated lighting schedule. In this case the program calculates the lighting power for the luminaire/lamp assembly and then multiplies this by the number of luminaires and the lighting schedule value. The electric lighting illuminance is also calculated.

The Library contains a variety of luminaires that you can choose from (see *DOE-2.2 Libraries & Reports*). The Library also contains a range of lamp sizes and types (see *DOE-2.2 Libraries & Reports*). For more details on this method see the description of the LIGHTING-SYSTEM, LUMINAIRE-TYPE and LAMP-TYPE commands and the overhead-lighting related keywords in the SPACE command.

ILLUMINANCE

You specify the lamp type, luminaire type and desired electric lighting illuminance when the lights are fully on. In this case the program first calculates the number of luminaires needed to meet the illuminance setpoint. Then it determines the lighting power for each luminaire and multiplies this by the lighting schedule value. For more details on this method see the description of the LIGHTING-SYSTEM, LUMINAIRE-TYPE and LAMP-TYPE commands and the overhead-lighting related keywords in the SPACE command.

Table 24 shows the SPACE lighting-related keywords associated with each of the above code-words.

Table 24 Space Lighting Specification Methods

LTG-SPEC-METHOD	Associated SPACE Keywords
POWER-DEFINITION	LIGHTING-KW or LIGHTING-W/AREA LIGHTING-TYPE LIGHTING-SCH
LUMINAIRE-COUNT	NO-OF-LUMINAIRES LIGHTING-SYSTEM LUM-SPACE-DIV CEIL-TO-LUM-DIS WORKPLANE-HEIGHT LIGHTING-SCH
ILLUMINANCE	ELEC-ILLUMINANCE LIGHTING-SYSTEM LUM-SPACE-DIV CEIL-TO-LUM-DIS WORKPLANE-HEIGHT CEIL-TO-LUM-DIS LIGHTING-SCH

LIGHTING-SCHEDULE

Takes a list of schedule names for each of up to 5 lighting subsystems. Each hour the peak connected electric lighting power for each subsystem is multiplied by the corresponding schedule value. LIGHTING-SCHEDULE applies whether you specify electric lighting with LIGHTING-SYSTEM or with LIGHTING-W/AREA and/or LIGHTING-KW.

For example, if a space has one lighting system, with schedule SCH-1, then LIGHTING-SCHEDULE = SCH-1. If a space has two lighting subsystems, one with schedule SCH-1 and one with schedule SCH-2, then LIGHTING-SCHEDULE = (SCH-1, SCH-2). If both subsystems have the same schedule, SCH-1, then LIGHTING-SCHEDULE = (SCH-1, SCH-1).

LIGHTING-TYPE

If LIGHTING-W/AREA or LIGHTING-KW is specified, LIGHTING-TYPE takes a list of codewords for up to five lighting subsystems that determine the radiative/convective split of heat from the lights (which is used in the room weighting factor calculation). Allowed values are the following:

- SUS-FLUOR Suspended, surface mounted or recessed/non-vented fluorescent or HID.
- REC-FLUOR-NV Recessed fluorescent or HID not vented to return air or supply air.
- REC-FLUOR-RV Recessed fluorescent or HID vented to return air.
- REC-FLUOR-RSV Recessed fluorescent or HID vented to supply and return air.
- INCAND Incandescent or tungsten-halogen.

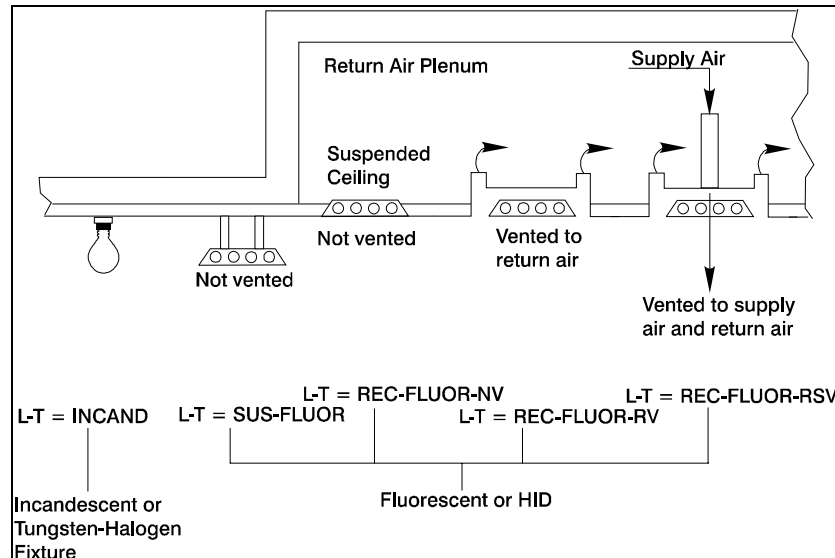

Figure 17 Examples of LIGHTING-TYPES

For LTG-SPEC-METHOD = POWER-DEFINITION, one or both of the following two keywords can be specified:

LIGHTING-W/AREA

Takes a list of values of electric lighting power per unit space floor area, including ballasts where applicable, for each of up to 5 lighting subsystems. Whether or not the subsystem serves the entire space, the value entered should be the total peak power for the subsystem (before multiplying by the lighting schedule) divided by the total space floor area. Each subsystem can have a different lighting schedule (see LIGHTING-SCHEDULE, below). Example input: if a space has two lighting subsystems, one with 0.5 W/ft2 and the other with 1.0 W/ft2, then LIGHTING-W/AREA = (0.5,1.0).

LIGHTING-KW

Takes a list of values of kilowatts of electric lighting power, including ballasts where applicable, for each of up to 5 lighting subsystems. The values entered should be peak connected power before multiplying by the lighting

schedule. Each subsystem can have a different lighting schedule (see LIGHTING-SCHEDULE, below). If both LIGHTING-W/AREA and LIGHTING-KW are entered, their contributions will be added.

Table 25
Distribution of Energy from LIGHTING-KW or LIGHTING-W/AREA

Type of Energy	Approximate percent for	
	Fluorescent	Incandescent
Visible Light	19	10
Infrared	31	72
Convection, Conduction	36	18
Ballast	14	0
(Eventually all the energy gets converted into SPACE load.)		

LIGHTING-SYSTEM

Takes a list of up to 5 U-names of previously defined LIGHTING-SYSTEM commands. Thus a space can have up to 5 different overhead lighting subsystems. Each subsystem can have a different schedule (see LIGHTING-SCHEDULE). If a space has just one room, then each subsystem can serve all or part of the room (see LUM-ZONE-FRAC). If the space has several rooms, then a room or groups of rooms can be assigned to different subsystems. If a space has several identical rooms, then LUM-SPACE-DIV can be used to simplify input and get a more accurate illuminance calculation. The electric lighting power for a space can be also be specified with the keywords LIGHTING-W/AREA and/or LIGHTING-KW. If either or both of these are entered than LIGHTING-SYSTEM should not be entered.

One, but not both, of the following two keywords is required if LIGHTING-SYSTEM is specified:

NO-OF-LUMINAIRES

For LIGHTING-SPEC-METHOD = LUMINAIRE-COUNT, takes a of list of up to 5 values of the number of luminaires corresponding to each of the subsystems in the above LIGHTING-SYSTEM list. The program will calculate the electric illuminance from the specified number of luminaires. Alternatively, if the following keyword, ELEC-ILLUMINANCE, is entered, then the program will calculate the number of luminaires (rounded up to the nearest whole number) for each subzone required to meet the specified illuminance values. In this case, NO-OF-LUMINAIRES should not be entered.

ELEC-ILLUMINANCE

For LIGHTING-SPEC-METHOD = ILLUMINANCE, takes a list of up to 5 values of the illuminance to be produced by each of the subsystems in the above LIGHTING-SYSTEM list. The program will calculate the number of luminaires for each subsystem required to meet the specified illuminance values. Alternatively, if NO-OF-LUMINAIRES is entered, then the program will calculate the illuminance from each subsystem. In this case, ELEC-ILLUMINANCE should not be entered. ELEC-ILLUMINANCE should only be used if the space consists of one room or several identical rooms (in which case LUM-SPACE-DIV can be specified). If the space consists of several non-identical rooms, you should use NO-OF-LUMINAIRES (but the calculated illuminance will be inaccurate), or you can divide the space into separate rooms.

LUM-SPACE-DIV

The number of rooms to divide a space into for the lighting calculation. It can be used to give a more accurate electric lighting calculation when a SPACE consists of two or more rooms that have the same size, surface reflectances, and lighting systems. An example would be a perimeter space with several identical offices. The

program will divide the space into LUM-SPACE-DIV identical rooms. If NO-OF-LUMINAIRES is specified, it should be the number per room, and the program will calculate the associated electric illuminance using coefficients of utilization for a single room rather than for the space as a whole. If ELEC-ILLUMINANCE is specified the program will calculate the number of luminaires in each room required to produce that lighting level. In either case, the program will calculate the total lighting power for the space as the power per room times LUM-SPACE-DIV.

CEIL-TO-LUM-DIS

For LIGHTING-SPEC-METHOD = LUMINAIRE-COUNT or ILLUMINANCE, takes a list of up to 5 values of the distance from the ceiling to the center plane of the luminaires in each of the subsystems in the LIGHTING-SYSTEM list. This keyword defaults to 0.0 for all subsystems, so need only be specified for suspended luminaires (those for which LUMINAIRE-CONFIG in the corresponding LIGHTING-SYSTEM command is SUSPEND-OPEN or SUSPEND-CLOSED). For sloped ceilings use average ceiling to luminaire distance.

WORKPLANE-HEIGHT

For spaces with DAYLIGHTING as YES and/or LIGHTING-SPEC-METHOD either LUMINAIRE-COUNT or ILLUMINANCE, the distance from the floor to the workplane at which illuminance is determined. Although defaulted, this value is required if LIGHTING-SYSTEM is specified. This keyword takes a single value that applies to all of the lighting subsystems. For the case when DAYLIGHTING is YES, this value is used for the calculation of daylighting coefficients of utilization for both the open space and for obstructions.

Distribution of Heat from Overhead Lights

The following keywords are used with all LTG-SPEC-METHODs. They determine how the heat from overhead lighting is distributed between the space, the return air, or an adjacent SPACE. If these keywords are specified they apply to all of the lighting subsystems in the SPACE. If these keywords are allowed to default and LTG-SPEC-METHOD = POWER-DEFINITION, the default values, shown in Table 26, apply separately to each subsystem according to its LIGHTING-TYPE. If these keywords are allowed to default and LIGHTING-SPEC-METHOD=LUMINAIRE-COUNT or ILLUMINANCE, the default values, shown in Table 27, are determined by the characteristics of the first subsystem in the LIGHTING-SYSTEM list and these values apply to all of the subsystems in that list.

When it is appropriate to have a non-zero value for LIGHT-TO-OTHER, its value should be chosen in the following way: assume that the return air path is through a duct and estimate the values of LIGHT-TO-SPACE and LIGHT-TO-RETURN under conditions of maximum air flow; now set $\text{LIGHT-TO-OTHER} = 1.0 - (\text{LIGHT-TO-SPACE}) - (\text{LIGHT-TO-RETURN})$. This procedure is valid even if you intend to simulate return air plenums in SYSTEMS. Depending upon the type of system being modeled in SYSTEMS, or upon the choice for RETURN-AIR-PATH in the SYSTEM command, the light heat that you have assigned to the return air path through the use of LIGHT-TO-RETURN will be treated as follows. If the HVAC system is zonal (that is, if SYSTEM:TYPE is UHT, UVT, HP, TPFC, FPFC, TPIU, FPIU, PTAC, or PVVI) or RETURN-AIR-PATH = DIRECT, QRETURN will be added to the zone load in SYSTEMS. If plenum zones are defined in SYSTEMS, then the return air path, along with QRETURN, is assumed to pass through the plenum zones. If there is a variable-volume fan, then the light heat to the return air is proportional to the airflow rate to the zone, with the residue of QRETURN being added to the zone load.

LIGHT-TO-SPACE

Fraction of the heat from overhead lighting that goes into the space. The rest goes into the return air or into an adjacent space, as determined by the keywords LIGHT-TO-OTHER, LIGHT-TO-RETURN, LIGHT-HEAT-TO, and LIGHT-RAD-FRAC.

LIGHT-TO-OTHER

The fraction of light heat that is deposited in an adjacent space. Unless the light fixture is in contact with an adjacent space or unless the interior wall between this space and the adjacent space is translucent or transparent, LIGHT-TO-OTHER should be zero.

LIGHT-HEAT-TO

Takes the U-name of an unconditioned or plenum space. This space receives the fraction of light heat specified as LIGHT-TO-OTHER. This is a required keyword if LIGHT-TO-OTHER > 0. Only unconditioned or plenum spaces may be the recipients of such heat from lights

**Table 26 Default values by LIGHTING-TYPE
for LTG-SPEC-METHOD=POWER-DEFINITION**

Lighting Type	Code Word	LIGHT-TO-SPACE	LIGHT-TO-OTHER	LIGHT-TO-RETURN	LIGHT-RAD-FRAC	
					This Space	Other Space
Fluorescent or HID lamp in a suspended or surfacemounted luminaire	SUS-FLUOR	1.0	0.0	0.0	0.67	1.0
Fluorescent or HID lamp in a recessed (return air vented) luminaire	REC-FLUOR-RV	0.8	0.0	0.2	0.59	0.09
Fluorescent or HID lamp in a recessed (return and supply vented) luminaire	REC-FLUOR-RSV	0.8	0.0	0.2	0.19	0.09
Fluorescent or HID lamp in a recessed (non vented) luminaire	REC-FLUOR-NV	1.0	0.0	0.0	0.67	0.09
Incandescent or tungsten halogen lamp in any type of luminaire	INCAND	1.0	0.0	0.0	0.71	1.0

Table 27 Default values for
LTG-SPEC-METHOD=LUMINAIRE-COUNT or ILLUMINANCEN

Lighting Type of First Lighting Subsystem	LIGHT-TO-SPACE	LIGHT-TO-OTHER	LIGHT-TO-RETURN	LIGHT-RAD-FRAC	
				This Space	Other Space
Fluorescent or HID lamp in a non-vented luminaire	1.0	0.0	0.0	0.67	0.09
Fluorescent or HID lamp in a vented luminaire	0.8	0.0	0.2	0.59	0.09
Incandescent or tungsten-halogen lamp in any type of luminaire	1.0	0.0	0.0	0.71	1.0
Fluorescent or HID lamp in a recessed (non vented) luminaire	1.0	0.0	0.0	0.67	0.09
Incandescent or tungsten halogen lamp in any type of luminaire	1.0	0.0	0.0	0.71	1.0

LIGHT-TO-RETURN

The fraction of light heat that goes directly into the return air stream. Unless the return air passes through the light fixtures, LIGHT-TO-RETURN should be zero. The default is $1.0 - (LIGHT-TO-SPACE + LIGHT-TO-OTHER)$.

LIGHT-RAD-FRAC

Takes a list of two fractions. The first is the fraction of the light heat to the space that is radiative. The second is the fraction of light heat to an adjacent space that is radiative. The second fraction, although required if this keyword is used, is not used if LIGHT-TO-OTHER = 0.

Daylighting

The following space daylighting-related keywords are used in the daylighting calculation, in which light sensors and controls reduce overhead electric lighting in response to illuminance levels of daylight from windows and skylights in the space. There are also daylighting-related keywords under the SITE-PARAMETERS, EXTERIOR-WALL, INTERIOR-WALL, GLASS-TYPE, and WINDOW commands. See also "Daylighting" in the *DOE-2.2 Topics*.

DAYLIGHTING

If YES, a daylighting calculation will be done for the space.

LIGHT-REF-POINT1, LIGHT-REF-POINT2

Takes a list of three values that gives the x, y, and z coordinates (in the space coordinate system) of the reference points at which daylight illuminance levels are to be calculated. If DAYLIGHTING = YES, then LIGHT-REF-POINT1 must be specified. If you want to divide a thermal zone installed lighting kW into two independently-controlled daylighting zones, then LIGHT-REF-POINT2 should also be specified. It is assumed that the photocells that control the electric lighting system respond to the light levels at the specified reference points.

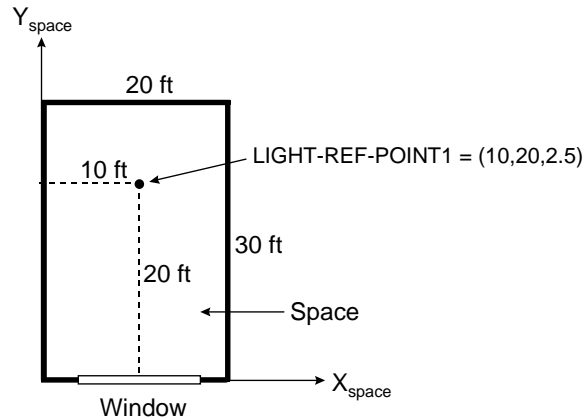

Figure 18 Plan view of a space.
 (The daylighting reference point is located at
 $x = 10$ ft, $y = 20$ ft and $z = 2.5$ ft in the space coordinate system.)

Example input:

If the lighting reference point is located at $x = 10$, $y = 20$, and $z = 2.5$ ft (see Figure 18), then,

$$\text{LIGHT-REF-POINT1} = (10, 20, 2.5)$$

If only one reference point is used, specification of this point must be done with some care if the daylighting results are to be meaningful. Lighting zones are generally laid out parallel to the plane of the glazing at a typical depth of 15ft (4.6m). Thus, a row of similar perimeter offices may be treated as a single space with a MULTIPLIER, with results from a single sensor being used to determine daylighting savings for the entire row. If the reference point is placed too near the window, the levels will be high relative to the rest of the space and will overpredict savings. A point at the back of the room will underpredict total savings. Since the drop-off in illuminance from vertical glazing is a function with an exponentially declining shape, a point just beyond the mid-point is usually selected as a reasonable location. Until more definitive data is available, the reference point should be placed at a point two-thirds of the zone depth back from the window wall. These guidelines assume the use of a ceiling-mounted sensor. Although these sensors may be located at a specific point in the room, they generally view the reflected light from a larger area in the room. Thus, the sensor itself tends to see an average light level.

ZONE-FRACTION1, ZONE-FRACTION2

Give the fraction of the installed lighting kW of the space controlled by lighting system 1 with its sensor “seeing” illuminance at LIGHT-REF-POINT1 and by lighting system 2 with its sensor “seeing” illuminance at LIGHT-REF-POINT2. The following rules apply:

1. ZONE-FRACTION2 is required if LIGHT-REF-POINT2 is specified.
2. If ZONE-FRACTION2 is specified, $(\text{ZONE-FRACTION1}) + (\text{ZONE-FRACTION2})$ should be 1.0.
3. If only LIGHT-REF-POINT1 is specified, then ZONE-FRACTION1 should not exceed 1.0.
4. If only LIGHT-REF-POINT1 is specified and ZONE-FRACTION1 is less than 1.0, then a fraction of the space equal to $1.0 - (\text{ZONE-FRACTION1})$ is assumed to be non-daylit.

5. If LIGHT-REF-POINT1 and LIGHT-REF-POINT2 are specified, i.e., the overhead electric lighting in that fraction of the space will not be reduced in response to daylighting levels, then (ZONE-FRACTION1) and (ZONE-FRACTION2) should not exceed 1.0.
6. If (ZONE-FRACTION1) + (ZONE-FRACTION2) is less than 1.0, then a fraction of the thermal zone equal to $1.0 - [(ZONE-FRACTION1) + (ZONE-FRACTION2)]$ is assumed to be non-daylit.

DAYLIGHT-REP-SCH

Takes the U-name of a schedule that specifies the time periods over which various entries in daylighting reports LS-G and LS-J are to be accumulated.

Example input: For space SP-1, accumulate report entries, such as percent lighting energy reduction by daylighting in report LS-G, only from 7am to 6pm on weekdays, i.e., only for the hours the space is occupied.

```
OCC-HOURS-1 = SCHEDULE
  THRU DEC 31 (MON,FRI) ( 1, 7)(0) (8,18)(1) (19,24)(0)
                (SAT) ( 1,24)(0)
                (SUN,HOL) ( 1,24) (0) . .

SP-1 = SPACE
DAYLIGHTING           = YES
DAYLIGHTING-REP-SCH = OCC-HOURS-1
```

Lighting Control Systems for Daylighting

The following space daylighting-related keywords are used to define the light sensors and controls that are installed to reduce overhead electric lighting in response to illuminance levels of daylight from windows and skylights in the space.

LIGHT-SET-POINT1, LIGHT-SET-POINT2

Give the desired illuminance level at LIGHT-REF-POINT1 and LIGHT-REF-POINT2, respectively.

Recommended values, which depend on type of activity, occupant age, and other factors, may be found on p. 460ff of the Lighting Handbook, Eighth Edition, 1995, Illuminating Engineering Society of North America. Typical values are shown in Table 28. It is assumed that this lighting level will be produced by the overhead electric lights at full output. These setpoints may be chosen to be lower when the overhead lights provide ambient lighting that is supplemented by task lighting. (The illuminance from task lighting is not included in LIGHT-SET-POINT1 or LIGHT-SET-POINT2.)

Table 28 Illuminance Values for Generic Types of Indoor Activities^a

Type of Activity	Range of Illuminance ^b	
	Footcandles	Lux
Public spaces with dark surroundings	2-3-5	20-30-50
Simple orientation for short, temporary visits	5-7.5-10	50-75-100
Working spaces where visual tasks are only occasionally performed	10-15-20	100-150-200
Performance of visual tasks of high contrast or large size	20-30-50	200-300-500
Performance of visual tasks of medium contrast or medium size	50-75-100	500-750-1000
Performance of visual tasks of low contrast or very small size	100-150-200	1000-1500-2000
Performance of visual tasks of low contrast and very small size over a prolonged period	200-300-500	2000-3000-5000
Performance of very special visual tasks of extremely low contrast and small size	500-750-1000	5000-7500-10000
^a Adapted from Fig. 11-1 in Lighting Handbook, Eighth Edition, 1995, Illuminating Engineering Society of North America ^b The three values given correspond to the low, midpoint, and high values for each type of activity		

LTG-CTRL-METHOD1, LTG-CTRL-METHOD2

Takes one of a list of 25 code-words that specifies the type of electric lighting control system at LIGHT-REF-POINT1 and LIGHT-REF-POINT2, respectively. For compatibility with earlier versions, the default value DefaultOrSpecified causes the defaults based on the values of other keywords to be used (those values are LIGHT-CTRL-TYPE1/2 as CONTINUOUS, MIN-POWER-FRAC/2 as 0.3, and MIN-LIGHT-FRAC/2 as 0.3); additionally there are 7 CONTINUOUS (Table 29) and 17 DISCRETE (Table 30) alternate control strategies. Note that if the LIGHT-CTRL-TYPE1, MIN-POWER-FRAC, or MIN-LIGHT-FRAC are directly given values then the defaults that would be assigned by the selection of the LTG-CTRL-METHOD1 keyword will not be used and thus the selected control strategy will not be modeled; those specified values would need to be removed to enable the selected strategy to be correctly modeled.

DefaultOrSpecified Specifies that default values are to be used for the LIGHT-CTRL-TYPE1, MIN-POWER-FRAC and MIN-LIGHT-FRAC.

Table 29 lists the predefined continuous dimming lighting controls for fluorescent lighting systems and for Metal Halide and High Pressure Sodium lighting systems in both high bay and low bay applications. Table 30 lists the predefined stepped lighting controls for a variety of lighting systems and applications. All of these controls utilize the new commands for specifying DISCRETE lighting control. The new method of specifying lighting power as a function of light output is similar to the existing STEPPED lighting control method, but is far more flexible in it's ability to specify as many as 10 lighting power levels and their associated lighting output. Values from both these tables are from the SkyCalc 2.0 default lighting controls.

Table 29 Predefined Continuous Lighting Control Specifications

LTG-CTRL-METHOD1 LTG-CTRL-METHOD2	MIN-POWER-FRAC	MIN-LIGHT-FRAC
Fluor:Dimming:5%Light	0.21	0.05
Fluor: Dimming: 10% Light	0.19	0.10
Fluor:Dimming:20%Light	0.36	0.22
MH:HighBay:Dimming:25%	0.56	0.25
MH:LowBay:Dimming:20%	0.51	0.19
HPS:HighBay:Dimming:5%	0.21	0.05
HPS:LowBay:Dimming:10%	0.29	0.10

Table 30 Predefined Discrete Lighting Control Specifications

LTG-CTRL-METHOD1 LTG-CTRL-METHOD2	DISCRETE-POWER1 DISCRETE-POWER2				DISCRETE-LIGHT1 DISCRETE-LIGHT2			
	1	2	3	4	1	2	3	4
On/Off	1	0			1	0		
Switch:2Level+Off	1	0.5	0		1	0.5	0	
Switch:3Level+Off	1	0.667	0.333	0	1	0.667	0.333	0
Switch:1/2On/Off	1	0.5			1	0.5		
Switch:1/3On/Off	1	0.667			1	0.667		
Switch:2/3On/Off	1	0.667	0.333		1	0.667	0.333	
Fluor:Hi/LoBallast	1	0.6			1	0.55		
MH:HighBay:Hi/LoBallast	1	0.48			1	0.22		
MH:HighBay:3PhaseHi/LoBallast	1	0.83	0.65	0.48	1	0.74	0.48	0.22
MH:LowBay:Hi/LoBallast	1	0.57			1	0.32		
MH:LowBay:3PhaseHi/LoBallast	1	0.86	0.71	0.57	1	0.77	0.55	0.32
HPS:HighBay:Hi/LoBallast	1	0.4			1	0.26		
HPS:HighBay:3PhaseHi/LoBallast	1	0.80	0.60	0.4	1	0.75	0.51	0.26
HPS:HighBay:3-LevelBallast	1	0.65	0.4		1	0.62	0.26	
HPS:LowBay:Hi/LoBallast	1	0.26			1	0.1		
HPS:LowBay:3PhaseHi/LoBallast	1	0.75	0.51	0.26	1	0.70	0.40	0.1
HPS:LowBay:3-LevelBallast	1	0.55	0.26		1	0.5	0.1	

LIGHT-CTRL-TYPE1, LIGHT-CTRL-TYPE2

Takes code-words that specify the type of electric lighting control system at LIGHT-REF-POINT1 and LIGHT-REF-POINT2, respectively

CONTINUOUS Specifies a dimming control system in which the electric light output and power input decrease continuously and linearly as the daylight illuminance increases. The control action at a daylighting reference point is illustrated in Figure 19 in terms of power input fraction (power input divided by maximum power input), as the daylight illuminance increases, and light output fraction (electric light output divided by maximum electric light output).

Figure 19 shows that, as the daylight illuminance increases, the fractional light output decreases from 1.0 (at zero daylight illuminance and maximum input power) to a value MIN-LIGHT-FRAC at the minimum power fraction, MIN-POWER-FRAC.

In the example shown in Figure 20 the lighting set point (LIGHT-SET-POINT1 or 2) is 45fc, MIN-POWER-FRAC is 0.3, and MIN-LIGHT-FRAC is 0.1. We see that at zero daylight illuminance the electric lights are on at full power and the electric illuminance is 50fc. As the daylighting illuminance increases, the electric power and lighting decrease, reaching a power fraction of 0.3 and an electric illuminance of 5fc ($50 * (\text{MIN-LIGHT-FRAC})$) when the daylight illuminance is 45 fc. Beyond this point, the electric power and illuminance stay constant as the daylighting illuminance increases.

CONTINUOUS/OFF Gives a dimming control similar to CONTINUOUS but the lights turn off completely (i.e., the electric light output and power are zero) when the total illuminance (electric illuminance plus daylighting illuminance) exceeds the lighting setpoint. The action is shown in Figure 21.

STEPPED Specifies the control system shown in Figure 22, in which power input and light output vary in discrete, **equally spaced** steps. The number of steps (excluding zero) is given by LIGHT-CTRL-STEPS.

DISCRETE Specifies the control system in which power input and light output vary in discrete, **variable spaced** steps. The number of steps is given by DISCRETE-POWER1 and its paired DISCRETE-LIGHT 1 for the first control point, and DISCRETE-POWER2 and DISCRETE-LIGHT2 for the second control point..

LIGHT-CTRL-STEPS, LIGHT-CTRL-STEP2

Gives the number of steps, excluding zero, in a stepped lighting control system. The steps are assumed to be equally spaced, as shown in Figure 22. An on-off control system has LIGHT-CTRL-STEPS=1. LIGHT-CTRL-STEPS applies to the lighting system 1, LIGHT-CTRL-STEP applies to the lighting system 2.

MIN-POWER-FRAC, MIN-POWER-FRAC2

Specifies the minimum input power fraction for a CONTINUOUS or CONTINUOUS/OFF lighting control system (see Figure 22). See manufacturer's data for appropriate value. MIN-POWER-FRAC applies to the lighting system 1, MIN-POWER-FRAC2 applies to the lighting system 2.

MIN-LIGHT-FRAC, MIN-LIGHT-FRAC2

Specifies the fractional light output that a CONTINUOUS or CONTINUOUS/OFF lighting control system produces at the minimum fractional input power given by MIN-POWER-FRAC (see Figure 22). See manufacturer's

data for appropriate value. MIN-LIGHT-FRAC applies to the lighting system 1, MIN-LIGHT-FRAC2 applies to the lighting system 2.

DISCRETE-POWER1, DISCRETE-POWER2

Takes a list of up to ten values of fraction power input to the lighting system that, together with DISCRETE-LIGHT1, defines the lighting power use as a function of lighting output when LIGHT-CTRL-TYPE1 or LIGHT-CTRL-TYPE2 is DISCRETE.

DISCRETE-LIGHT1, DISCRETE-LIGHT2

Takes a list of up to ten values of fraction light output from the lighting system that, together with DISCRETE-POWER1, defines the lighting power use as a function of lighting output when LIGHT-CTRL-TYPE1 or LIGHT-CTRL-TYPE2 is DISCRETE.

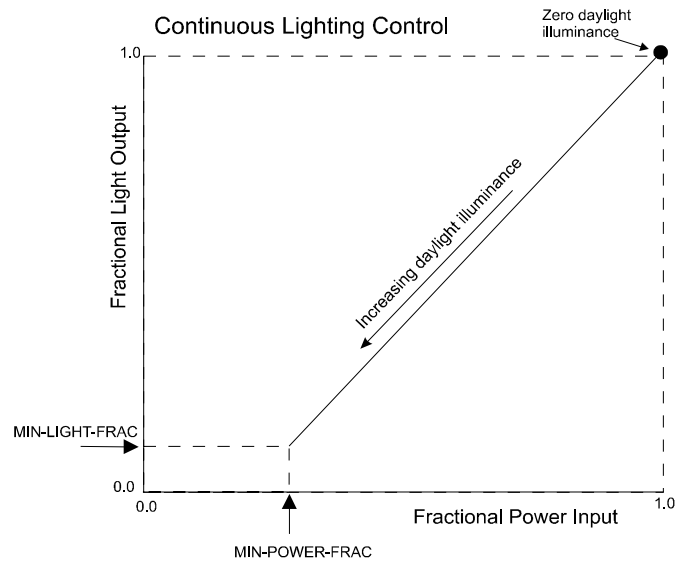

Figure 19 Light output vs. electrical power input for a CONTINUOUS lighting control system

CONTINUOUS Lighting Control

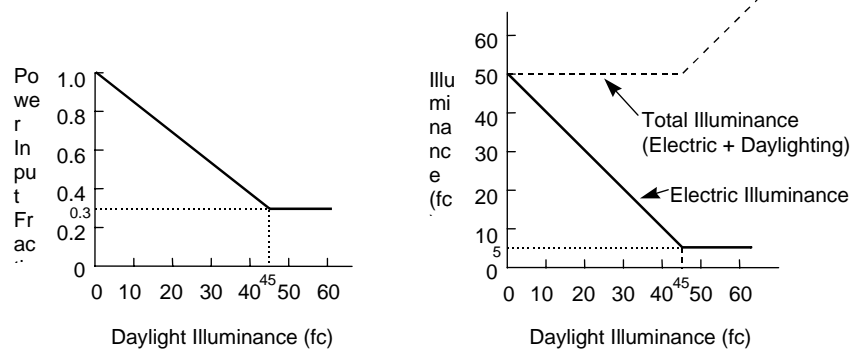

Figure 20 Control action for a lighting system with CONTINUOUS lighting control. [The lighting set point is 45 fc (482 lux), the minimum power input fraction (MIN-POWER-FRAC) is 0.3, and the minimum electric lighting output fraction (MIN-LIGHT-FRAC) is 0.1]

CONTINUOUS/OFF Lighting Control

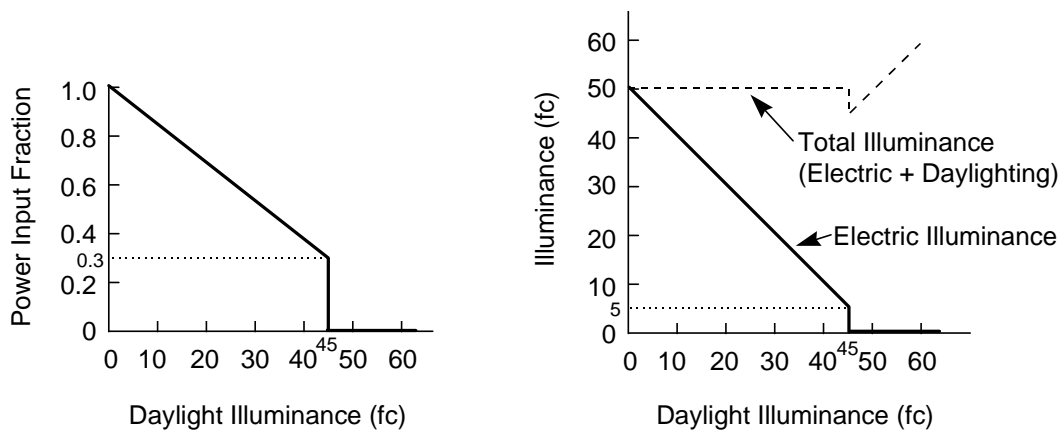

Figure 21 Control action for CONTINUOUS/OFF lighting control. [The lighting set point is 45 fc (482 lux), the minimum power input fraction (MIN-POWER-FRAC) is 0.3, and the minimum electric lighting output fraction (MIN-LIGHT-FRAC) is 0.1]

STEPPED Lighting Control

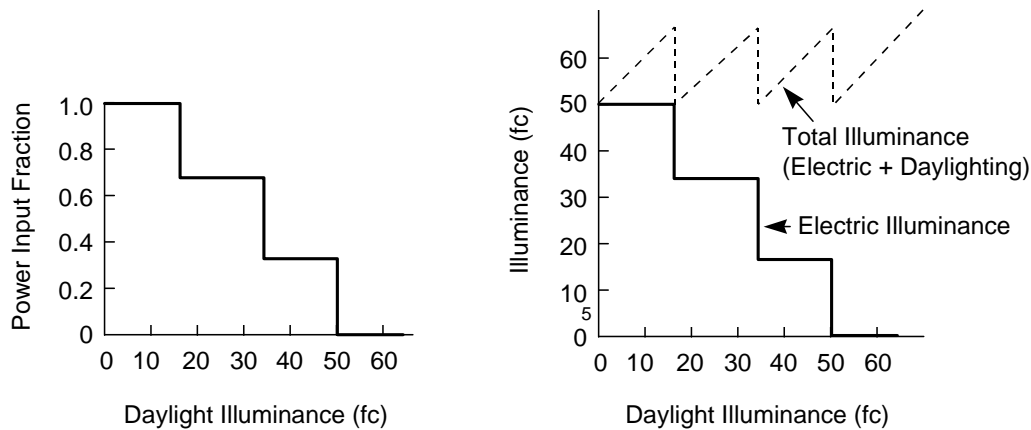

Figure 22 Control action for STEPPED lighting control.
 [The lighting set point is 50 fc (538 lux) and the number of steps (LIGHT-CTRL-STEPS) is 3]

Occupancy Shade and Lighting Control with Daylighting

The following space daylighting-related keywords are used to define how occupants may interact with the lighting controls or with the deployment of shades.

LIGHT-CTRL-PROB, LIGHT-CTRL-PROB2

May be specified if a stepped lighting control system is manually operated, such as in a simple one-step, on-off system. LIGHT-CTRL-PROB gives the probability the occupants of a daylit space will set the electric lights to the correct level to obtain the required illuminance. The rest of the time the lights are assumed to be set one step too high. For example, consider an on-off system with LIGHT-SET-POINT1 = 60, LIGHT-CTRL-TYPE1 = STEPPED, LIGHT-CTRL-STEPS = 1, and LIGHT-CTRL-PROB = 0.7. Then, when daylighting exceeds 60 fc, the electric lights will be off 70 percent of the time and on 30 percent of the time. LIGHT-CTRL-PROB applies to the lighting system 1, LIGHT-CTRL-PROB2 applies to the lighting system 2.

MAX-GLARE, MAX-GLARE2

The program will automatically deploy window shading devices to reduce daylight glare (if WIN-SHADE-TYPE = MOVABLE-INTERIOR or MOVABLE-EXTERIOR) whenever the glare (at either lighting reference point) with bare windows exceeds the MAX-GLARE value. Table 31 below gives recommended MAX-GLARE values for different situations. For example, MAX-GLARE = 22 would be specified for general office work. If a space has two or more windows, the shading devices will be deployed one by one in the order in which the windows are input, until the glare level at each lighting reference point falls below MAX-GLARE. If MAX-GLARE is not specified, no glare control will occur. This is a daylighting keyword; see TOPIC - DAYLIGHTING. MAX-GLARE applies to the lighting system 1, MAX-GLARE2 applies to the lighting system 2.

Table 31 Recommended MAX-GLARE values

Activity	MAX-GLARE	Activity	MAX-GLARE
Art Galleries	16	Laboratories	22
Factories		Museums	20
Rough Work	28	Offices	
Engine Assembly	26	General	22
Fine Assembly	24	Drafting	20
Instrument Assembly	22	School Classrooms	20
Hospital Wards	18		

VIEW-AZIMUTH, VIEW-AZIMUTH2

Direction of occupant view (in the horizontal plane), measured as a clockwise angle from the space y-axis (see Figure 23). It is used by the program to calculate daylight glare. If not specified, VIEW-AZIMUTH will be calculated by the program for a view direction parallel to the first window in the space (obtained by rotating clockwise by 90 (the horizontal projection of the window outward normal). In general, the daylight glare contribution from a particular window is highest when the occupant faces the window. VIEW-AZIMUTH applies to the lighting system 1, VIEW-AZIMUTH2 applies to the lighting system 2.

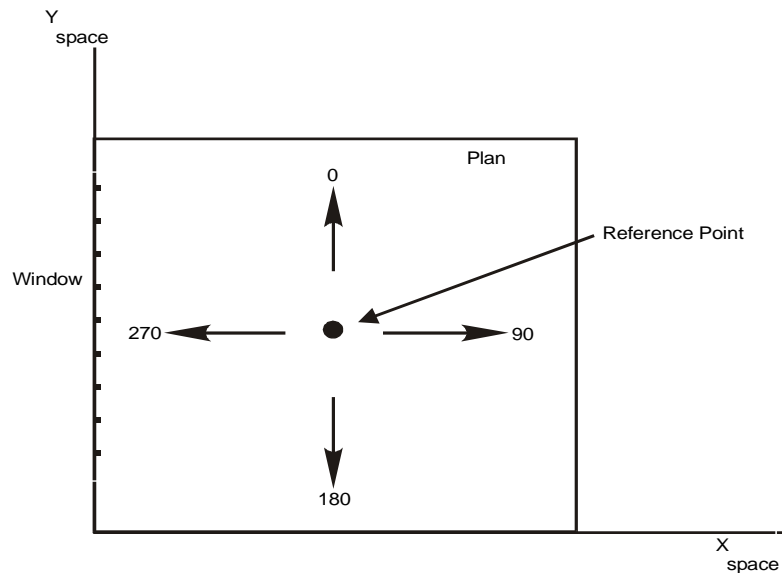

Figure 23 VIEW-AZIMUTH for four occupant view directions. (Daylight glare from the window is greatest when facing window)

The Interaction of Space Contents with Daylighting

The following space daylighting-related keywords are used to define how the contents of the space act to obstruct the daylight from reaching the work plane and thus decrease the ability of daylight to allow the reduction of overhead electric lighting power use.

VERT-OBS1-FACTOR, VERT-OBS2-FACTOR

These factors, which are numeric values from 0.0 to 1.0, represent the fraction of daylight from windows with WINDOW-TYPE allowed to default or set to STANDARD that will reach the work plane specified by LIGHT-REF-POINT1 and LIGHT-REF-POINT2, respectively. This value is less than 1.0 if space obstructions are to be taken into account when calculating the daylight contribution to work plane illuminence.

SKY-OBS1-METHOD, SKY-OBS2-METHOD

Accepts a codeword that specifies how the SKY-OBS1-FACTOR and SKY-OBS2-FACTOR values are obtained. These factors represent the fraction of daylight from skylights that will reach the work plane; this value is less than 1.0 if space obstructions are to be taken into account when calculating the daylight contribution to work plane illuminence.

SPECIFY	Use a specified value for SKY-OBS1-FACTOR or SKY-OBS2-FACTOR
CALCULATE	Specifies the values for SKY-OBS1-FACTOR or SKY-OBS2-FACTOR is to be calculated based upon entered or defaulted values of the type and size of the obstructions..

SKY-OBS1-FACTOR, SKY-OBS2-FACTOR

When SKY-OBS1-METHOD or SKY-OBS2-METHOD is SPECIFY, accepts a numeric value that represents the fraction of daylight from skylights that reaches the work plane. Applies to daylighting contribution from windows with WINDOW-TYPE set to SKYLIGHT-FLAT or SKYLIGHT-DOMED.

SKY-OBS1-TYPE, SKY-OBS2-TYPE

When SKY-OBS1-METHOD or SKY-OBS2-METHOD is CALCULATE, accepts a codeword that specifies the type of space obstructions are to be taken into account when calculating the daylight contribution to work plane illuminence. If obstructions are selected to be modeled, their dimensions can either be specified or allowed to default; default obstruction dimensions are based upon the obstruction type and the space dimensions including height, with and depth (or area if the shape is a polygon.)

NONE	Specifies that no interior obstructions are to be modeled as reducing daylight from skylights to the work plane.
SHELVES/RACKS	Specifies that rows of shelves are to be modeled as reducing daylight from skylights to the work plane; the obstructions will take on sizes either from default values typical of shelves and racks or may be specified.
PARTITIONS	Specifies that partitions, or cubicles, are to be modeled as reducing daylight from skylights to the work plane; the obstructions will take on sizes either from default values typical of partitions for the defined space geometry (space height and area) or may be specified.

SKY-OBS1-HT, SKY-OBS2-HT

When SKY-OBS1-METHOD or SKY-OBS2-METHOD is CALCULATE, accepts a numeric value that specifies typical height of the obstructions to skylight daylight. For shelves or partitions this is the typical height of the top of the shelves/partitions above the floor.

SKY-OBS1-WID, SKY-OBS2-WID

When SKY-OBS1-METHOD or SKY-OBS2-METHOD is CALCULATE, accepts a numeric value that specifies typical width of the obstructions to skylight daylight. For shelves this is the typical depth of the shelves from front to back. For partitions this is the typical width of the partitions.

SKY-OBS1-LEN, SKY-OBS2-LEN

When SKY-OBS1-METHOD or SKY-OBS2-METHOD is CALCULATE, accepts a numeric value that specifies typical width of the obstructions to skylight daylight. For shelves this is the typical width of the aisles between the shelves. For partitions this is the typical length of the partitions perpendicular to the direction of their specified width (using SKY-OBS1-WID or SKY-OBS2-WID.)

SKY-OBS1-REFL, SKY-OBS2-REFL

When SKY-OBS1-METHOD or SKY-OBS2-METHOD is CALCULATE, accepts a numeric value that specifies typical reflectance of the obstructions to skylight daylight.

SKY-CU-SPC-HT, SKY-CU-SPC-WID, SKY-CU-SPC-LEN

When SKY-OBS1-METHOD or SKY-OBS2-METHOD is CALCULATE, these are numeric values that specify the space height, width and length to be used when calculating the open (unobstructed) space coefficient of utilization for daylight from skylights. These will default to the defined space geometry using the space area if the shape is a polygon.

Task Lighting

The following keywords apply to task lights, which are small lamps, such as desk lamps, that have a different schedule of use than the overhead lighting. The program assumes that task lights are fluorescent when calculating the radiative/convective split by the heat from this lighting. It also assumes that 100 percent of the heat from task lighting goes into the space, so the LIGHT-TO-SPACE keyword does not apply. Unlike overhead lighting, which can have up to five subsystems, only one task lighting system is allowed in a space.

TASK-LIGHT-SCH

Takes the U-name of a SCHEDULE for task lighting in the space. Schedule inputs are fractions of maximum task lighting electrical input (see TASK-LIGHTING-KW and TASK-LT-W/AREA). If the TASK-LIGHT-SCH is not input, the schedule value defaults to zero and no task lights are simulated.

TASK-LIGHTING-KW

The maximum electrical power required for task lighting. The actual task lighting power required in the space during any given hour is the value assigned to this keyword multiplied by the fractional value of TASK-LIGHT-SCH for that hour. If both TASK-LIGHTING-KW and TASK-LT-W/AREA are specified, the program adds the values.

TASK-LT-W/AREA

Maximum task lighting power per unit of floor area of the space. The keyword LIGHT-TO-SPACE is not appropriate because 100 percent of task lighting energy goes to the space. This keyword is an alternative to TASK-LIGHTING-KW. TASK-LT-W/AREA times space area times the value of TASK-LIGHT-SCH determines hourly task lighting electricity use and heat output. If both TASK-LT-W/AREA and TASK-LIGHTING-KW are specified, the contributions are added.

Equipment**EQUIP-SCHEDULE**

Takes a list of U-names of operation schedules to and up to five types of space electrical equipment. Schedule inputs are fractions of maximum equipment power (see EQUIPMENT-KW and EQUIPMENT-W/AREA). For example, if a space has two equipment types, say computers and copy machines, one with schedule SCH-COMP and the other with schedule SCH-COPY, then

```
EQUIP-SCHEDULE=(SCH-COMP, SCH-COPY)
```

If there is only one equipment type, with schedule SCH-1, the parentheses around the list is not required, so that

EQUIP-SCHEDULE = SCH-1

and

EQUIP-SCHEDULE = (SCH-1)

are equivalent.

If the EQUIP-SCHEDULE is not input, the schedule values default to zero and no space equipment loads are simulated.

EQUIPMENT-W/AREA

Takes a list of values of maximum equipment power per unit floor area of the space for up to five types of electrical equipment. An alternative to EQUIPMENT-KW. If both EQUIPMENT-W/AREA and EQUIPMENT-KW are specified, the contributions are added. The program calculates the electrical power in watts for all of the equipment in a space as

$$\text{Watts} = (\text{EQUIPMENT-KW} * 1000 + \text{AREA} * \text{EQUIPMENT-W/AREA}) * (\text{EQUIP-SCHEDULE value})$$

for all equipment types.

The EQUIP-SENSIBLE and EQUIP-LATENT keywords give the fraction of heat gain for each equipment type that is sensible and latent, respectively. The total hourly heat gain from all of the equipment (for all of the equipment types) is, therefore:

$$\text{Qwatts} = \text{Watts} * (\text{EQUIP-SENSIBLE} + \text{EQUIP-LATENT})$$

EQUIPMENT-KW

Takes a list of values of maximum power required to operate up to five types of electrical equipment within the space. This keyword is an alternative to EQUIPMENT-W/AREA. If both are specified, the contributions are added. The description of the EQUIPMENT-W/AREA keyword, above, indicates how the total hourly equipment electricity use and heat output are calculated. The actual equipment energy required by the space during any given hour is the value assigned to this keyword multiplied by the fractional value assigned to that hour (see EQUIP-SCHEDULE). The amount of equipment energy added to the space may be specified by its components (see EQUIP-LATENT and EQUIP-SENSIBLE). If both EQUIPMENT-KW and EQUIPMENT-W/AREA are specified, the program adds the values. Before specifying a value for EQUIPMENT-KW, review SOURCE-TYPE = ELECTRIC, below. In EQUIPMENT-KW you specify equipment; in SOURCE-TYPE you specify a utility demand.

EQUIP-SENSIBLE

Takes a list of values, for up to five equipment types, of the fraction of EQUIPMENT-W/AREA or EQUIPMENT-KW that is added to the space as sensible heat. The sum of EQUIP-LATENT and EQUIP-SENSIBLE, for each equipment type, must not exceed 1.0. For example, assume there are two equipment types in a space. The first has a maximum electrical use of 0.6 W/ft², with a sensible fraction of 0.7 and a latent fraction of 0.3. The second has a maximum electrical use of 0.8 W/ft², with a sensible fraction of 1.0 and a latent fraction of zero. Then

EQUIPMENT-W/AREA	=	(0.6, 0.8)
EQUIP-SENSIBLE	=	(0.7, 1.0)
EQUIP-LATENT	=	(1.0, 0.0)

If neither EQUIP-SENSIBLE nor EQUIP-LATENT is specified, all heat from equipment is considered sensible.

EQUIP-LATENT

Takes a list of values, for up to five equipment types, of the fraction of EQUIPMENT-W/AREA or EQUIPMENT-KW that is added to the space as sensible heat. The sum of EQUIP-SENSIBLE and EQUIP-LATENT, for each equipment type, must not exceed 1.0.

Space Heat Sources**SOURCE-TYPE**

Used when there are internal heating or cooling loads caused by a source other than people, lights, or equipment. Associated code-words represent space heating (e.g., ovens) or cooling loads (e.g., ice rink). See note under keyword SOURCE-BTU/HR.

GAS	The load contributes to natural gas use. Examples include natural gas for ovens, kilns, or dryers. Do not use the code-word GAS to specify gas heated hot water; instead, specify SOURCE-TYPE=HOT-WATER. This will pass a demand for hot water to the HVAC program, where the hot water heater is specified along with its fuel type.
ELECTRIC	The load contributes to electricity use. Examples include electricity for electroplating or battery charging. Do not use the code-word ELECTRIC for specifying electrically heated hot water; instead, specify SOURCE-TYPE=HOT-WATER. This will pass a demand for hot water to the HVAC program, where the hot water heater is specified along with its fuel type.
HOT-WATER	The load contributes to the hot-water budget use in the HVAC program. This load will be reported as a domestic hot water load. The hot water loads will be passed to any domestic hot water heater defined in the HVAC input.
PROCESS	The load will not contribute a utility load. Examples of this type of load are gasoline-powered fork trucks, oxyacetylene welders, wood stoves, and bottled gas equipment. Sum all the process loads in the space and express the total with the keyword SOURCE-POWER. The portion of the total process load that enters as a heating or cooling load is specified with the SOURCE-LATENT and SOURCE-SENSIBLE keywords.

SOURCE-POWER

The maximum power supplied by the source defined by SOURCE-TYPE. This is the power required to operate devices, other than lighting and equipment, within the space. SOURCE-POWER is usually positive, which means heat is added to the space. However, if SOURCE-TYPE = PROCESS and the process involves cooling that removes heat from the space, then SOURCE-POWER should be entered as a negative number.

The fraction of SOURCE-POWER that contributes to the space conditioning load is specified with the SOURCE-SENSIBLE and SOURCE-LATENT keywords, below.

SOURCE-SCHEDULE

Takes the U-name of the schedule (with TYPE=MULTIPLIER) for any source of internal energy (such as process equipment within a space) other than people, lights, or electrical equipment. Schedule values are fractions of SOURCE-POWER. If SOURCE-SCHEDULE is not entered, the schedule values will default to zero and no source loads are simulated.

SOURCE-SENSIBLE

Fraction of SOURCE-POWER added to the space as a sensible load. The sum of SOURCE-SENSIBLE and SOURCE-LATENT must not exceed 1.0 and is may be less than 1.0 if all such energy is not necessarily added to the space load.

SOURCE-LATENT

The fraction of SOURCE-POWER added to the space as a latent load. The sum of SOURCE-LATENT and SOURCE-SENSIBLE must not exceed 1.0 and may be less than 1.0 if all such energy is not added to the space load.

Infiltration

The following keywords specify the outside air infiltration for a space.

INF-SCHEDULE

Takes the U-name of a schedule of TYPE=MULTIPLIER that contains values that multiply the calculated infiltration values. A value of 1.0 would leave the infiltration rates unmodified. Any value below 1.0 would represent reduction of infiltration such as that caused by pressurization from a supply fan. Any value above 1.0 would represent an increase in infiltration such as that caused by an exhaust fan, open window, or open door. If INF-SCHEDULE is not input the schedule defaults to 1.0 for all hours. Ordinarily, INF-SCHEDULE should not be used with INF-METHOD = CRACK or RESIDENTIAL method of infiltration because the schedule will distort wind information from the weather tape.

INF-METHOD

Takes a code-word that identifies the method used to calculate infiltration for the space (Table 32). Depending on INF-METHOD and associated keywords, the infiltration rate may or may not depend on local windspeed and inside-outside temperature difference.

NONE	No infiltration is calculated.
AIR-CHANGE	The infiltration rate is calculated using the air-change method. AIR-CHANGES/HR or INF-FLOW/AREA should be specified if INF-METHOD = AIR-CHANGE. In this case the value AIR-CHANGES/HR will be corrected for wind speed each hour, but the value of INF-FLOW/AREA will not be corrected. If both AIR-CHANGES/HR and INF-FLOW/AREA are specified, the resulting infiltration rates are added.
RESIDENTIAL	The infiltration rate is determined by the values of RES-INF-COEF and depends on wind speed and outside-inside temperature difference.
S-G	Sherman-Grimsrud Infiltration Method. Applies only to single-zone. Uses keywords HOR-LEAK-FRAC, NEUTRAL LEVEL and FRAC-LEAK AREA.
CRACK	In the case of the Crack Method, a value should be entered for the INF-COEF keyword in the EXTERIOR-WALL instruction, and for the keyword INF-COEF in the WINDOW instruction.

AIR-CHANGES/HR

The number of infiltration-caused air changes per hour at a reference wind speed of 10 mph (4.47 m/s) (see table under INF-METHOD). It has a correction for wind speed as shown by the following equation.

$$\text{Infiltration in ach} = (\text{AIR-CHANGES/HR}) * (\text{wind-speed})/(\text{reference wind speed})$$

(This keyword should not be confused with a keyword of the same name in SYSTEMS.)

INF-FLOW/AREA

The amount of infiltration into a space expressed as a ratio of air flow to floor area.

Table 32
Infiltration-Related Keywords for Different Infiltration Methods

INF-METHOD	Associated SPACE Keywords	Wind Speed Correction?*	Inside-Outside Temp Difference Correction?
AIR-CHANGE	AIR-CHANGES/HR INF-FLOW/AREA INF-SCHEDULE	AIR-CHANGES/HR – Yes INF-FLOW/AREA - No	No
RESIDENTIAL	RES-INF-COEF INF-SCHEDULE	Yes	Yes
S-G	FRAC-LEAK-AREA HOR-LEAK-FRAC NEUTRAL-LEVEL INF-SCHEDULE	Yes	Yes
CRACK	INF-COEF (for EXTERIOR-WALL, WINDOW and DOOR) INF-SCHEDULE	Yes	No

* Infiltration methods with wind speed correction depend also on the following SITE-PARAMETER keywords, which affect local wind speed: SHIELDING-COEF, TERRAIN-PAR1, TERRAIN-PAR2, WS-TERRAIN-PAR1, WS-TERRAIN-PAR2 and WS-HEIGHT.

RES-INF-COEF

For INF-METHOD = RESIDENTIAL, takes a list of three values that are coefficients in the following equation:

$$\text{Infiltration} = \text{value1} + (\text{value2} \times \text{windspeed}) + (\text{value3} \times (T))$$

where infiltration is measured in air changes/hr, windspeed in knots (or m/s) at the building location and (T is the absolute value of outdoor-indoor temperature difference) in F (or K).

NEUTRAL-ZONE-HT

For INF-METHOD = CRACK, used to compute a pressure difference between the inside and outside of a tall building caused by air density gradient ("stack effect"). The value to be entered is calculated as follows. Let the neutral pressure level (NPL) by the line on the building exterior where the pressure difference between the inside and outside results solely from the stack effect equals zero. The height of NPL is typically one half the building height. The value of NEUTRAL-ZONE-HT is the distance from the center of the exterior wall of the space to NPL. This distance is positive if the space center is below NPL and negative if above NPL.

HOR-LEAK-FRAC

For INF-METHOD = S-G, the leakage area and the leakage distribution are needed to compute the stack effect term. HOR-LEAK-FRAC is the fraction of the leakage that is in the floor and ceiling. A value of 0.3 is appropriate if there are few ceiling penetrations. Otherwise, the default of 0.4 may be used.

NEUTRAL-LEVEL

For INF-METHOD = S-G, the dimensionless height of the neutral level. That is, it is the fraction of the height of the space at which the indoor-outdoor pressure difference due to stack effect is zero. In general this keyword can be allowed to default to 0.5.

Weighting-Factor Related Keywords

The following keywords affect the weighting factors for a space. See "Weighting Factors" in the *DOE-2.2 Topics*.

FLOOR-WEIGHT

Specifies the composite weight of the floor, furnishings, and interior walls of a space divided by the floor area of the space. The input value determines the weighting factors associated with the space. Higher values give a longer lag time between heat gains and resultant cooling loads, and greater damping of peak loads. If 0.0 is input (the default) the program will calculate Custom Weighting Factors. For other values ASHRAE weighting factors are used

FURNITURE-TYPE

Takes a code-word that describes the thermal response of the furniture in the space. Used only for Custom Weighting Factor calculation.

LIGHT represents a furniture density of approximately 40 lb/ft³ (641 kg/m³) of furniture (like pine furniture).

HEAVY represents a furniture density of approximately 80 lb/ft² (1282 kg/m³).

FURN-FRACTION

Fraction of floor area covered by furniture. Determines the fraction of the incoming solar radiation absorbed by the furniture. Used only for the Custom Weighting Factor calculation.

FURN-WEIGHT

Weight of the furniture divided by the total floor area of the space. For example, if the furniture weighs 1000 lb and the total floor area is 500 ft², then FURN-WEIGHT = 2.0. Used only for the Custom Weighting Factor calculation.

Input Functions

The following keywords cause Input Functions to be calculated for the space. For more information, see the description of the FUNCTION command. See also "Input Functions" in the *DOE-2.2 Topics*.

FUNCTION

Invokes a function calculation for this SPACE.

DAYL-ILLUM-FN

Invokes a function calculation for daylighting of this SPACE. This function is called in the LOADS subroutine DINTIL, which determines the hourly daylight illuminance and glare index at each reference point in a space

DAYL-LT-CTRL-FN

Invokes a function calculation for the daylighting controls of this SPACE. This function is called in the LOADS subroutine DLTSYS, which determines the electric lighting reduction in response to daylight illuminance at each reference point in a space.

TROMBE-WALL-NV

This command is used to enter a Trombe wall. The Trombe wall consists of a heavy-weight wall (usually concrete) covered on the outside by a window (usually insulating glass). The window is separated from the wall by an air gap. The Trombe wall is not vented, i.e., the air in the gap does not circulate between the adjacent room and the gap or between the outside and the gap. Trombe walls are used for passive solar heating: solar radiation absorbed by the wall is conducted into the adjacent room after a time delay that depends on the construction and thickness of the wall. The simulation requires the following information:

1. The size, location, and orientation of the Trombe wall.
2. The glazing in the window that covers the wall. The amount and scheduling of window insulation.
3. The wall materials.
4. The channel width of the air gap and the emissivity of the wall.

Trombe walls are synonymous, in terms of keywords, with EXTERIOR-WALLS. The Trombe wall keywords are described under the EXTERIOR-WALL command.

Specifying TROMBE-WALL-NV tells the program to model an unvented Trombe wall in the given space. The window that covers the Trombe wall is indicated by following the TROMBE-WALL-NV command by a WINDOW command or specifying a WINDOW U-name for the WINDOWS keyword. Use of the keywords SHADING-SCHEDULE and CONDUCT-SCHEDULE allows you to simulate movable insulation placed over the glass. The material description of the wall is entered in the same way as a regular wall, i.e., through the MATERIAL, LAYERS, and CONSTRUCTION commands. U-name may be used to identify each Trombe wall. LIKE may be used to copy a previously-defined Trombe wall.

Rules

1. Only one TROMBE-WALL-NV is allowed per SPACE.
2. Each TROMBE-WALL-NV must have one, and only one, WINDOW.
3. The window area must equal the Trombe wall area.
4. To get time-delayed heat transfer through the wall, use a CONSTRUCTION of TYPE=LAYERS. Also, be sure that the ABSORPTANCE keyword value in the CONSTRUCTION is high in order to maximize the amount of solar radiation absorbed by the wall.
5. The CONSTRUCTION command referenced by TROMBE-WALL-NV command must, in turn, reference a WALL-PARAMETERS command.
6. The amount of solar heat that flows from the wall to the room will be enhanced if the outer wall surface has a low-emissivity coating (low value of EMISSIVITY in WALL-PARAMETERS).

The WALL-PARAMETERS keywords used for Trombe walls are shown in Table 33.

Table 33
WALL-PARAMETERS keywords for TROMBE-WALL-NV

Keyword	Input Value or Range	Default
FOR	TROMBE-WALL-NV	--
EMISSIVITY	0.0 - 1.0	0.93
CHANNEL-WIDTH	0.0 - 1.0 ft (0.0 - .30 m)	None

Example input:

```

TWLAY = LAYERS
  MAT              = ("CMU HW 12in ConcFill (CB17)") ..

TWPARS = WALL-PARAMETERS
  FOR              = TROMBE-WALL-NV
  CHANNEL-WIDTH   = 0.3333 ..

TWCONS = CONSTRUCTION
  LAYERS           = TWLAY
  WALL-PARAMETERS = TWPARS ..

TROMWGLASS = GLASS-TYPE
  GLASS-TYPE-CODE = 2000 ..
  . . . . .

SPACE1-1 = SPACE
  . . . . .

FRONT-1 = TROMBE-WALL-NV
  SURFACE-TYPE    = WALL
  HEIGHT          = 8
  WIDTH           = 20
  X               = 0
  Y               = 0
  Z               = 0
  AZ              = 180
  CONSTRUCTION    = TWCONS ..

WF-1 = WINDOW
  HEIGHT          = 8
  WIDTH           = 100
  GLASS-TYPE      = TROMWGLASS ..
  . . . . .
    
```

UNDERGROUND-WALL

UNDERGROUND-FLOOR

These equivalent commands specify the size and construction of a wall (such as a basement wall) or a floor (such as a slab-on-grade) that is in contact with the ground. Each UNDERGROUND-WALL or UNDERGROUND-FLOOR instruction applies to the SPACE instruction preceding it and describes one of the underground walls or underground floors of that SPACE. LIKE may be used to copy a previously defined wall or floor. Note that the U-EFFECTIVE keyword in previous versions of the program is no longer used. It has been replaced by PERIM-EXPOSED and PERIM-CONDUCT.

Example input:

Concrete slab-on-grade entered as an UNDERGROUND-FLOOR. \$ See "Underground Surfaces" in the *DOE-2.2 Topics* for a description of how to input the floor's layers and how to choose the perimeter conductance (PERIM-CONDUCT) and perimeter exposed to outside air (PERIM-EXPOSED). Note that the construction should always contain a 12-in layer of soil on the ground side of the underground surface.

```
LAY-SLAB-1 = LAYERS
  MATERIAL          = ("Soil 12in",
                     "Conc HW 140lb 4in (CC03)")
  INSIDE-FILM-RES   = 0.77 ..

CON-SLAB-1 = CONSTRUCTION
  TYPE              = LAYERS
  LAYERS            = LAY-SLAB-1 ..

SLAB-1 = UNDERGROUND-FLOOR
  HEIGHT            = 50
  WIDTH             = 100
  TILT              = 180
  PERIM-CONDUCT     = 0.68
  PERIM-EXPOSED    = 300
  CONSTRUCTION      = CON-SLAB-1 ..
```

SURFACE-TYPE

Takes a code-word that is used to set the default TILT value for the surface. CEILING or ROOF give TILT=0, FLOOR gives TILT = 180, WALL gives TILT=90. These values can be overridden by specifying the TILT keyword.

CONSTRUCTION

Takes the U-name of a previously-defined or library entry CONSTRUCTION command that describes the layer-by-layer construction of the wall or floor. This is a required keyword.

One of these layers in the construction should be a 1-ft (0.305-m) layer of soil on the ground side of the wall or floor. This layer can be chosen from the Library; it is "Soil 12in".

AREA

Area of the UNDERGROUND-WALL or UNDERGROUND-FLOOR. Use either AREA or HEIGHT/WIDTH or LOCATION or POLYGON.

HEIGHT, WIDTH

The height and width, respectively, of a rectangular wall or floor. Use either AREA or HEIGHT/WIDTH or LOCATION or POLYGON. HEIGHT is the dimension along the y-axis of the surface; WIDTH is the dimension along the x-axis.

AZUMITH

Clockwise angle between the parent space's Y-axis and the horizontal projection of the surface outward normal. See "Geometry" in the *DOE-2.2 Topics*.

TILT

Angle between vertical and the surface outward normal. TILT = 90 for a vertical wall; TILT = 180 for a horizontal floor. See "Geometry" in the *DOE-2.2 Topics*. The default value of TILT is determined by the value of the SURFACE-TYPE keyword. If SURFACE-TYPE is not specified, the default TILT for UNDERGROUND-WALL is 90 and the default tilt for UNDERGROUND-FLOOR is 180. Note that using SET-DEFAULT for UNDERGROUND-WALL will also reset the defaults for UNDERGROUND-FLOOR.

X**Y****Z**

Coordinates of the lower left-hand corner of the surface (as viewed from the ground side) in the space coordinate system. See "Geometry" in the *DOE-2.2 Topics*.

PERIM-EXPOSED

Not yet implemented. The length of the perimeter portion of the surface exposed to outside air. See "Underground Surfaces" in the *DOE-2.2 Topics* for examples of how to choose a value for this keyword. This is a required keyword.

PERIM-CONDUCT

Not yet implemented. This is a required keyword, equal to the effective conductance of the surface per unit length of exposed perimeter. A value can be chosen from the tables in "Underground Surfaces" in the *DOE-2.2 Topics*. The value depends on several factors, including:

1. The type of surface: slab on grade, basement wall or crawl space wall.
2. The placement and amount of foundation insulation.
3. If slab on grade, whether it is bare or carpeted.

MULTIPLIER

The number of identical underground surfaces located in the same plane. Multiplies the area of the surface.

LOCATION

If the surface is in a SPACE with SHAPE=BOX, then TOP, BOTTOM, LEFT, RIGHT, FRONT, or BACK is used to indicate on which face of the box the surface is located. From this, and the SPACE keywords HEIGHT, WIDTH, and DEPTH, the program determines the surface's values of X, Y, Z, HEIGHT, WIDTH, AZIMUTH, and TILT.

If the surface is in a SPACE with SHAPE=POLYGON, then SPACE-V1, SPACE-V2, etc., are used to orient and size the surface in spaces where the SPACE:POLYGON keyword specifies the footprint of the space.

LOCATION = SPACE-V1 means that the lower left hand corner of the surface is located at the vertex 1 of the space POLYGON. The program then positions the surface so that it is vertical (TILT=90) and its x-axis passes through vertex 1 and vertex 2 of the space POLYGON (which determines the surface's AZIMUTH). The surface HEIGHT is set to HEIGHT of the SPACE and the surface WIDTH is set to the vertex 1 to vertex 2 distance. A

similar procedure is followed for LOCATION = SPACE-V2, SPACE-V3, etc. If LOCATION = TOP (BOTTOM) the wall is positioned as a ceiling (floor) of the space, with a shape that is the same as the space POLYGON.

POLYGON

Takes the U-name of a previously-defined POLYGON command. This keyword is used in place of HEIGHT and WIDTH to describe non-rectangular surfaces. See the POLYGON Command. See also "Geometry" in the *DOE-2.2 Topics*.

SOLAR-FRACTION

The fraction of the solar radiation entering a space that is absorbed by this underground surface. Used by the program to calculate custom weighting factors for solar heat gain (see "Weighting Factors" in the *DOE-2.2 Topics*). A caution message will be issued if the sum of the SOLAR-FRACTIONS for a given space is not within 10 percent of 1.0, and the program will adjust the SOLAR-FRACTIONS so that their sum is 1.0. The program multiplies each SOLAR-FRACTION by a factor that accounts for the amount of incoming solar radiation that is reflected back out of the space through the glazing.

If all SOLAR-FRACTIONS for a space are allowed to default, the program will assume that 60% of the incoming solar radiation is absorbed by the floor; the remaining 40% will be distributed to the other surfaces (excluding windows), according to their surface areas. If there is no floor, the full 100% will be distributed to the surfaces (excluding windows), according to their surface areas.

To override this default procedure, you can explicitly specify SOLAR-FRACTION values for all the surfaces or for some of the surfaces. If not all of the SOLAR-FRACTIONS are input, the program will sum the values specified and distribute the balance (up to 1.0) to the other surfaces. For example, if you specify SOLAR-FRACTION = 0.7 for the floor only, the program will distribute the remaining 0.3 to the walls and ceiling, according to their area and INSIDE-SOL-ABS value.

The distribution of absorbed solar radiation depends on the space geometry and surface absorptances, as well as on the hourly varying position of the sun relative to the space. It also depends on the hourly varying proportions of direct and diffuse solar radiation entering the space. Since you can enter only one set of SOLAR-FRACTIONS for a SPACE, the SOLAR-FRACTIONS should be chosen to represent a time-average over the run period of the analysis, with emphasis given to those times of day and seasons of the year when solar gain is greatest.

Note: SOLAR-FRACTION is not affected by MULTIPLIER; it applies to the surface area after multiplication.

INSIDE-SOL-ABS

Inside surface solar absorptance. This is the fraction of the solar radiation incident on the opaque part of the wall from the inside that is absorbed (the rest being reflected). The program uses the INSIDE-SOL-ABS values to (1) determine the inside solar radiation distribution in sunspaces (see "Sunspaces" in the *DOE-2.2 Topics*); and (2) to calculate SOLAR-FRACTIONS when not all SOLAR-FRACTIONS in a space have been specified (see SOLAR-FRACTION keyword, above).

Note that SOLAR-FRACTION and INSIDE-SOL-ABS for a surface are related but are not generally equal.

INSIDE-VIS-REFL

Inside surface visible reflectance (hemispherical average). Used only for daylighting calculation.

FUNCTION

Invokes a function calculation for this surface. See the FUNCTION command; see also "Input Functions" in the *DOE-2.2 Topics*.

WALL-PARAMETERS

Specifies data used to calculate air flow across a sunspace INTERIOR-WALL. Also specifies emissivity and channel width data for a Trombe wall entered with the TROMBE-WALL-NV command. The U-name of this command is referenced by the CONSTRUCTION command for INTERIOR-WALL and TROMBE-WALL-NV.

Example input:

```

WP-1 = WALL-PARAMETERS
  FOR                INTERIOR-WALL
  AIR-FLOW-TYPE      = FORCED-RECIRC
  AIR-FLOW-RATE      = 200
  AIR-FLOW-CTRL-DT   = 2.5
  FAN-KW             = -0.005 ..

IWCON-1 = CONSTRUCTION
  WALL-PARAMETER     = WP-1
  LAYERS              = LAY-1
  . . .

IW-1 = INTERIOR-WALL
  CONSTRUCTION        = IWCON-1
  . . .

```

FOR

Takes a code-word specifying the type of WALL-PARAMETERS

INTERIOR-WALL	the wall parameters are for a sunspace interior wall
TROMBE-WALL-NV	the wall parameters are for an unvented Trombe wall

TROMBE-WALL-NV keywords

EMISSIVITY

The emissivity of the outside wall surface.

CHANNEL-WIDTH

Width of the air gap in a Trombe wall; i.e., the distance between the inside surface of the WINDOW and the outside surface of the wall. Width between vented walls. Required for TROMBE-WALL.

Sunspace INTERIOR-WALL air flow keywords

The following keywords are used only for when there is airflow across an INTERIOR-WALL between a sunspace and a non-sunspace. See "Sunspaces" in the *DOE-2.2 Topics*.

LOWER-VENT-AREA, UPPER-VENT-AREA

Area of the lower vent opening for AIR-FLOW-TYPE = FREE-RECIRC.

VERT-VENT-SEP

Center-to-center vertical separation between the upper and lower vents for AIR-FLOW-TYPE = FREE-RECIRC.

AIR-FLOW-TYPE

Takes a code-word that specifies the type of air flow across the INTERIOR-WALL (see Figure 24).

FORCED-RECIRC A fan blows air through a vent from the sunspace to the adjacent space at a rate equal to AIR-FLOW-RATE. Air is recirculated back to the sunspace through another vent. All of the fan heat is assumed to be picked up by the airstream flowing into the adjacent space.

FORCED-OA-PREHT A fan draws outside air into the sunspace where it is pre-heated, then transferred across the INTERIOR-WALL into the adjacent space. The fan is assumed to be located in the building exhaust airstream so that no fan heat is delivered to the building. The flowrate of outside air drawn into the sunspace is the same as the flowrate from the sunspace across the INTERIOR-WALL.

FREE-RECIRC Air circulates through upper and lower vents in the INTERIOR-WALL by natural convection. The heat transfer from sunspace to adjacent space is calculated by the program as

$$Q = 31267 C_p P \left[\frac{h |T_s - T_R|}{T_s T_R \left(\frac{T_s}{A_U^2} + \frac{T_R}{A_L^2} \right)} \right]^{\frac{1}{2}} (T_s - T_R) ,$$

where

- Q is in Btuh
- CP equals the heat capacity of air (Btu/lb-F)
- P equals the atmospheric pressure (in. Hg)
- h equals the vertical separation between vents pressure (ft)
- TS equals the sunspace air temperature (F)
- TR equals the air temperature of the adjacent space (F)
- AU equals the upper vent area (ft²)
- AL equals the lower vent area (ft²)

FREE-DOORWAY Air circulates by natural convection through a doorway in the INTERIOR-WALL. The heat transfer from sunspace to adjacent space when the doorway is fully open is given by

$$Q = 4.6 W H^{\frac{3}{2}} |T_s - T_R|^{\frac{1}{2}} (|T_s - T_R|) ,$$

where

- Q is in Btuh
- W equals the width of the opening (ft)
- H equals the height of the opening (ft)
- TS equals the sunspace air temperature (F)
- TR equals the air temperature of the adjacent space (F)

Table 34
WALL-PARAMETERS keywords for sunspace INTERIOR-WALL

Keyword	AIR-FLOW-TYPE			
	FORCED-RECIRC	FORCED-OA-PREHT	FREE-RECIRC	FREE-DOORWAY
LOWER-VENT-AREA			Yes	
UPPER-VENT-AREA			Yes	
VERT-VENT-SEP			Yes	
AIR-FLOW-RATE	Yes	Yes		
AIR-FLOW-CTRL-DT	Yes	Yes	Yes	Yes
FAN-KW/FLOW	Yes	Yes		
DOORWAY-H				Yes
DOORWAY-W				Yes

AIR-FLOW-RATE

Air flow rate across a sunspace INTERIOR-WALL for AIR-FLOW-TYPE = FORCED-RECIRC or FORCED-OA-PREHT. Used only if AIR-FLOW-TYPE = FORCED-RECIRC or FORCED-OA-PREHT.

AIR-FLOW-CTRL-DT

Threshold temperature difference for control of air flow across a sunspace INTERIOR-WALL. Air flow will occur only if: T (sunspace)-T (adjacent space) > AIR-FLOW-CTRL-DT.

The default value is 3.0F (1.66K) for all AIR-FLOW-TYPEs except FORCED-OA-PREHT, in which case it is -100F (-55K) (therefore the keyword has no effect if not specified for FORCED-OA-PREHT).

FAN-KW/FLOW

The electric power per unit air flow of the fan for AIR-FLOW-TYPE=FORCED-RECIRC or FORCED-OA-PREHEAT.

Sunspace air flow types

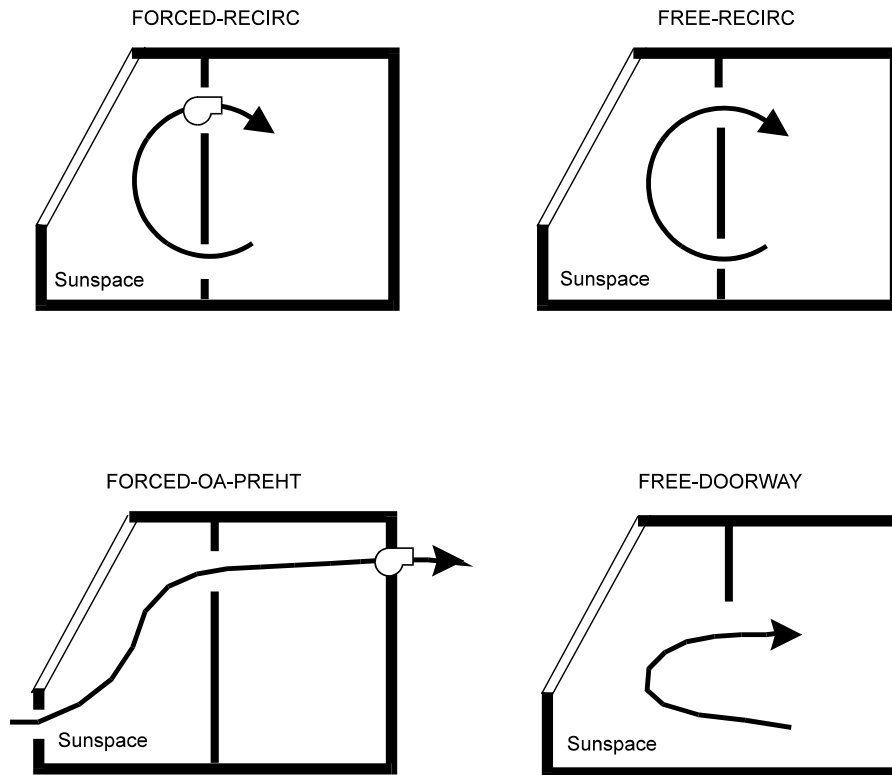

Figure 24 Sunspace INTERIOR-WALL air flow configurations

DOORWAY-H

Height of the INTERIOR-WALL opening through which air flow occurs for AIR-FLOW-TYPE = FREE-DOORWAY

DOORWAY-W

Width of the INTERIOR-WALL opening through which air flow occurs for AIR-FLOW-TYPE = FREE-DOORWAY. Multiple openings of height H_i and width W_i in the same wall can be represented by a single opening with DOORWAY-H = $\langle H \rangle$ and DOORWAY-W =

To get solar radiation transmitted across an unglazed opening, a WINDOW with GLASS-TYPE-CODE = 0, GLASS-CONDUCTANCE = 0.0001, HEIGHT = same value as DOORWAY-H, and WIDTH = same value as DOORWAY-W, should be placed in the sunspace INTERIOR-WALL.

WINDOW

Specifies the size, position, number, and glazing properties of a window in an EXTERIOR-WALL or in a sunspace INTERIOR-WALL. A GLASS-TYPE instruction must precede a WINDOW instruction. LIKE may be used to copy data from a previously entered and U-named WINDOW. U-name may be specified.

Example input:

```
WF-1 = WINDOW
  X           = 12
  Y           = 3
  WIDTH      = 20
  HEIGHT     = 4
  GLASS-TYPE = GT-1 . .
```

X

Y

X and Y are the coordinates of the bottom left-hand corner of the glazed part of the window (when viewed from the outside of the window) in the wall coordinate system. If X is not specified, the program will center the window horizontally on the wall; if Y is not specified the program will center the window vertically.

HEIGHT

Height of the glazed part of the window.

WIDTH

Width of the glazed part of the window.

WINDOW-TYPE

Takes a code-word that indicates the method of inputting the solar-thermal characteristics of the window glazing. The choice of window type will determine default value for the window as well as how the window utilizes other daylighting properties.

STANDARD	Default. Indicates that the window is composed of standard vertical flat glass glazing with an optional frame. This window will use VERT-OBS1-FACTOR & VERT-OBS2-FACTOR for daylighting calculations and will not be affected by obstructions associated with skylights.
SKYLIGHT-FLAT	Indicates that the window is a skylight using flat glass glazing. This type of window includes a default curb and frame and utilizes inputs for skylight obstructions (see below). This window type can have an associated light well used for daylighting calculations.
SKYLIGHT-DOMED	Indicates that the window is a skylight using domed glazing. Default solar transmittance properties are included along with a default dome depth. This type of window also includes a default curb and frame and utilizes inputs for a light well and for skylight obstructions (see below).
SKYLIGHT-TUBULAR	Indicates that the window is a skylight using a tubular daylighting device with an exterior domed glazing, a light tube with high interior reflectivity and an optional diffuser at the bottom of the tube. Default solar transmittance properties appropriate for a domed glazing surface are included along with a default dome depth. This type of window also includes a default curb and frame and utilizes

inputs for skylight obstructions (see below) but does not have an associated light well.

MULTIPLIER

Specifies the number of identical windows in the wall. **MULTIPLIER** multiplies the area of window.

WIN-SPEC-METHOD

Takes a code-word that indicates the method of inputting the solar-thermal characteristics of the window glazing.

GLASS-TYPE-INPUT Indicates that the **GLASS-TYPE** keyword will be used to reference a previously-entered or library **GLASS-TYPE** command. This input method is used when you want to describe the glazing by using the shading coefficient approach, or by getting the glazing characteristics from the Library. See the **GLASS-TYPE** command.

LAYERS-INPUT Indicates that the **WINDOW-LAYERS** keyword will be used to reference one or more previously-entered or library **WINDOW-LAYER** commands. This input method is used when you want to describe a window layer by layer. See the **WINDOW-LAYER** command.

GLASS-TYPE

Takes the U-name of a previously-entered or library **GLASS-TYPE** command. This is a required keyword when **WIN-SPEC-METHOD=GLASS-TYPE-INPUT**.

DIFFUSING-GLASS

Takes a code-word that indicates the diffusing characteristics of the window glazing.

YES Indicates that the glazing is diffusing, and that all transmitted energy (thermal or visible) arrives inside the window as diffuse.

NO Indicates that the glazing is not diffusing, and that energy (thermal or visible) is transmitted through the window based on the direct and diffuse incident solar radiation.

DIRT-DEPREC-SCH

Takes the U-name of a previously-entered or library **SCHEDULE** command of **TYPE FRACTION** or **MULTIPLIER**. This schedule defines an hourly multiplier on, or fractional value of, the visible light, as well as direct and diffuse solar, transmitted through the window. This value represents the effect of dirt accumulation on the window and acts in a very similar manner as the **SHADING-SCHEDULE** in that the visible light and transmitted solar gain is reduced to this fractional value. The reduction in transmittance is assumed to result in an equal increase in absorptance; the hourly absorptance of the outermost pane of glass is increased by the sum of the reduction of direct and diffuse solar, as defined hourly by one minus the value of **DIRT-DEPREC-SCH** times the unaltered direct and diffuse transmission amounts.

INSIDE-VIS-REFL

Visible reflectance (hemispherical average) of the inside surface of the window. Used only for exterior windows in spaces with **DAYLIGHTING=YES**. This keyword can be allowed to default unless the window has a high-reflectance shade that is in place during most of the daylight hours, in which case it should be set to the visible reflectance of the shade.

Skylight Glass and Daylighting Properties

The following keywords are used to provide added detail for the modeling of skylights when WINDOW-TYPE is SKYLIGHT-FLAT, SKYLIGHT-DOMED or SKYLIGHT-TUBULAR. See “Window Frames and Skylight Curbs” for details on the specification of frame and curb properties for skylights.

Domed Skylight Properties

The following keywords are used for the modeling of skylights when WINDOW-TYPE is SKYLIGHT-DOMED or SKYLIGHT-TUBULAR.

DOME-DEPTH

When WINDOW-TYPE is SKYLIGHT-DOMED or SKYLIGHT-TUBULAR, accepts a numeric value that is the dome projection above the plane of the skylight frame. For tubular daylighting devices this value is defaulted based on the TUBE-DIAMETER. For rectangular domed skylights this value is defaulted based upon the minimum dimension of the skylight height and width.

SKY-TRANS-ANG

When WINDOW-TYPE is SKYLIGHT-DOMED or SKYLIGHT-TUBULAR, accepts a list of up to ten values of direct solar incident angle upon the outside surface of the window glazing, that together with the paired value of SKY-TRANS-ANG provides the transmitted solar energy relative to the value for normal incident solar.. For skylights that do not utilize flat glass the transmitted visible and solar heat is calculated using the direct normal value times a multiplier derived from the solar incident angle and the SKY-TRANS-ANG and SKY-TRANS-MULT keywords; the two keywords are used to provide a piece-wise linear relation that the calculation uses with hourly linear interpolation. The first value should be 0.0 (normal incidence) and the last value should be 90.0. Default values for SKY-TRANS-ANG and SKY-TRANS-MULT are provided for standard domed skylights and tubular daylighting devices; new values can be entered for specific skylight dome shapes if the required information is available.

SKY-TRANS-MULT

When WINDOW-TYPE is SKYLIGHT-DOMED or SKYLIGHT-TUBULAR, accepts a list of up to ten values of solar transmission through the window glazing, that together with the paired value from SKY-TRANS-ANG (which is the direct solar incident angle upon the outside surface) provides the transmitted solar energy relative to the value for normal incident solar.. For skylights that do not utilize flat glass the transmitted visible and solar heat is calculated using the direct normal value times a multiplier derived from the solar incident angle and the SKY-TRANS-ANG and SKY-TRANS-MULT keywords; the two keywords are used to provide a piece-wise linear relation that the calculation uses with hourly linear interpolation. The values should be the ratio, at the corresponding angle value of SKY-TRANS-ANG, of skylight transmission divided by the value of transmission at normal incident angle for the window GLASS-TYPE. Default values for SKY-TRANS-ANG and SKY-TRANS-MULT are provided for standard domed skylights and tubular daylighting devices; new values can be entered for specific skylight dome shapes if the required information is available. Default values are found in the Table 35

Table 35 Skylight Transmission Multipliers

Value position	SKYLIGHT-DOMED		SKYLIGHT-TUBULAR	
	SKY-TRANS-ANG	SKY-TRANS-MULT	SKY-TRANS-ANG	SKY-TRANS-MULT
1	0.0	1.0	0.0	1.0
2	90.0	1.0	50.0	1.0
3			70.0	0.95
4			78.0	0.88
5			81.0	0.85
6			83.0	0.85
7			87.0	1.0
8			90.0	1.1

Skylight Light Well Daylighting Properties

The following keywords are used for the modeling of skylights when WINDOW-TYPE is SKYLIGHT-FLAT or SKYLIGHT-DOMED. The specification of a light well replaces the need for the user to modify the visible transmittance of the glass type used for the window based on a manually calculated light well efficiency.

LIGHT-WELL

When WINDOW-TYPE is SKYLIGHT-FLAT or SKYLIGHT- DOMED, accepts a codeword that allows a light well to be defined for the skylight. The light well, if specified, will be placed directly under the window (and only the window with this keyword set as YES) and will have a direct impact upon the daylight contribution from this window to the parent space.

NO Indicates that no window light well is to be modeled for this window.

YES Indicates that a light well is to be modeled for the daylighting contribution for this window to its parent space.

WELL-EFF-METHOD

When WINDOW-TYPE is SKYLIGHT-FLAT or SKYLIGHT- DOMED, accepts a codeword method by which the overall light well daylighting visible light transmittance will be obtained. Unless the user has specific information about an unusual light well, it is recommended that the program be allowed to calculate the well efficiency.

SPECIFY Indicates that the overall light well visible transmittance efficiency will be supplied via the keyword WELL-EFFICIENCY.

CALCULATE Indicates that the overall light well visible transmittance efficiency will be calculated by DOE-2 using a coefficient of utilization methodology.

WELL-EFFICIENCY

When WINDOW-TYPE is SKYLIGHT-FLAT or SKYLIGHT- DOMED and WELL-EFF-METHOD is SPECIFY, accepts a numeric value that is the overall light well visible transmittance efficiency.

WELL-DEPTH

When WINDOW-TYPE is SKYLIGHT-FLAT or SKYLIGHT- DOMED and WELL-EFF-METHOD is CALCULATE, this is a required numeric value that is the depth of the a light well under the skylight frame. This value is the distance from the inside edge of the frame of the skylight to the bottom of the well (usually at the space ceiling level.)

WELL-WIDTH-BOT

When WINDOW-TYPE is SKYLIGHT-FLAT or SKYLIGHT- DOMED and WELL-EFF-METHOD is CALCULATE, accepts a numeric value that is the width of the well at the ceiling level. This value defaults to the window WIDTH.

WELL-LENGTH-BOT

When WINDOW-TYPE is SKYLIGHT-FLAT or SKYLIGHT- DOMED and WELL-EFF-METHOD is CALCULATE, accepts a numeric value that is the length (equivalent to window height) of the well at its bottom. This value defaults to the window HEIGHT.

WELL-VIS-REFLECT

When WINDOW-TYPE is SKYLIGHT-FLAT or SKYLIGHT- DOMED and WELL-EFF-METHOD is CALCULATE, accepts a numeric value that is the visible reflectance (hemispherical average) of the inside surface of the well walls.

Tubular Skylight Daylighting Device Properties

The following keywords are used for the modeling of skylights when WINDOW-TYPE is SKYLIGHT-TUBULAR. A primary parameter is the Tube diameter. Additionally, a set of keywords allows for the calculation of a visible-transmittance correction factor for tubular skylight devices. This assumes that the visible transmittance entered for the GLASS-TYPE assigned to the window command does not already account for the tube. The only required keyword is TUBE-EFFICIENCY; that value can be either specified or calculated.

TUBE-DIAMETER

When WINDOW-TYPE is SKYLIGHT-TUBULAR, is a required numeric value that is the diameter of the tube (and dome at its base) at the point of the intersection of the dome and tube with the device mounting frame. When TUBE-EFF-METHOD is CALCULATE this value is used in the calculation of the overall tubular device visible transmittance efficiency. This value will also be used in calculation of tubular window “area” and in defaulting the window height and width **only** if the height and width are not specified (allowed to default – or set to default) when the WINDOW-TYPE is changed from an alternate value to SKYLIGHT-TUBULAR.

TUBE-EFF-METHOD

When WINDOW-TYPE is SKYLIGHT-TUBULAR, accepts a codeword method by which the overall tubular device daylighting visible light transmittance will be obtained.

SPECIFY	Indicates that the overall tubular device visible transmittance efficiency will be supplied via the keyword TUBE-EFFICIENCY (which then becomes required).
CALCULATE	Indicates that the over tubular device visible transmittance efficiency will be calculated by DOE-2 using an hourly methodology based on TUBE-DIAMETER, TUBE-LENGTH and TUBE-VIS-REFLECT..

TUBE-EFFICIENCY

When WINDOW-TYPE is SKYLIGHT-TUBULAR and TUBE-EFF-METHOD is SPECIFY, accepts a numeric value that is the overall tubular device visible transmittance efficiency.

TUBE-LENGTH

When WINDOW-TYPE is SKYLIGHT-TUBULAR and TUBE-EFF-METHOD is CALCULATE, accepts a numeric value that is the length of the tube from the frame mounting to the diffuser at the opposite end of the tube from the exterior dome.

TUBE-VIS-REFLECT

When WINDOW-TYPE is SKYLIGHT-TUBULAR and TUBE-EFF-METHOD is CALCULATE, accepts a numeric value that is the visible reflectance of the inside surface of the tube.

TUBE-DIFF-TRANS

When WINDOW-TYPE is SKYLIGHT-TUBULAR and TUBE-EFF-METHOD is CALCULATE, accepts a numeric value that is the visible transmittance of the diffuser at the bottom of the tube.

Describing a Window Using Layers

A window can be described layer by layer using the following WINDOW-LAYERS keyword.

Example input: A window consists of a layer of glass named GLASS-1, a gap named GAP-1 and a blind named BLIND-1.

```
GLASS-1 = WINDOW-LAYER . . . .
GAP-1   = WINDOW-LAYER . . . .
BLIND-1 = WINDOW-LAYER . . . .

WIN-1   = WINDOW
        WIN-SPEC-METHOD = LAYERS-INPUT
        WINDOW-LAYERS    = (GLASS-1, GAP-1, BLIND-1)
        . . . .
```

WINDOW-LAYERS

Takes a list of up to nine U-names of WINDOW-LAYER commands or of window layers from the Library. This is a required keyword when WIN-SPEC-METHOD=LAYERS-INPUT. A U-name corresponds to a glass layer, a gap layer or a blind layer (see WINDOW-LAYER command). Figure 25 shows examples of layered windows for single- and double-glazed windows.

Glass layers in the Library are shown in "Glass Layer Library," in the *DOE-2.2 Libraries & Reports*. Gap layers in the library are shown in Table 36. Blind layers in the library are shown in Table 37. Pull-down shade layers (pull-down shades modeled as closed blinds) in the library are shown in Table 38.

Notes:

1. The layers are entered from outside to inside.
2. There can be up to five solid (i.e., glass or blind) layers.
3. There can be at most one blind layer.
4. If there is a blind layer there must also be one or more glass layers; i.e., a layered window consisting only of a blind is not allowed.
5. Adjacent solid layers are not allowed; i.e., solid layers must be separated by one, and only one, gap layer.

6. Adjacent gap layers are not allowed; i.e., gap layers must be separated by one, and only one, solid layer.
7. A blind layer can be the first layer (exterior blind), the last layer (interior blind), or an intermediate layer (between-glass blind).
8. The gas in the gap on the inside of an exterior blind or the outside of an interior blind must be air.
9. The gaps on either side of a between-glass blind must have the same gas (but this gas does not need to be air).

Table 36
Gap Layers in the Library

U-name	Gas	Thickness
Air-6.3mm	Air	6.3mm (0.25in)
Air-12.7mm	Air	12.7mm (0.5in)
Argon-6.3mm	Argon	6.3mm (0.25in)
Argon-12.7mm	Argon	12.7mm (0.5in)
Krypton-6.3mm	Krypton	6.3mm (0.25in)
Krypton-12.7mm	Krypton	12.7mm (0.5in)

Table 37
Blind Layers in the Library

Names	Orient	Thickness	Width	Separation	Tsol	Rfsol	Rbsol	Tvis	Rfvis	Rbvis
Metal-1in-Lt	Horizontal	.2mm (.008in)	25mm (1.0in)	19mm (.75in)	0.	.7	.7	0.	.7	.7
Metal-1in-Med	Horizontal	.2mm (.008in)	25mm (1.0in)	19mm (.75in)	0.	.5	.5	0.	.5	.5
Metal-1in-Dark	Horizontal	.2mm (.008in)	25mm (1.0in)	19mm (.75in)	0.	.3	.3	0.	.3	.3

Note: All of these library entries have SLAT-ANGLE = 45.
These entries can be used for blinds that have different widths or separation from those in the library as long as Separation/Width = 0.75.

Key:

- | | |
|-------------------------------------|--------------------------------|
| Orient = ORIENTATION | Rfsol = REFL-SOL-BH |
| Thickness = THICKNESS | Rbsol = BACKREFL-SOL-BH |
| Width = SLAT-WIDTH | Tvis = TRANS-VIS-BH |
| Separation = SLAT-SEPARATION | Rfvis = REFL-VIS-BH |
| Tsol = TRANS-SOL-BH | Rbvis = BACKREFL-VIS-BH |

Table 38
Pull-Down Shade Layers in the Library

Name	Tsol	Rfsol	Rbsol	Tvis	Rfvis	Rbvis
Shade-Thin-T05-R10	.05	.10	.10	.05	.10	.10
Shade-Thin-T05-R30	.05	.30	.30	.05	.30	.30
Shade-Thin-T05-R50	.05	.50	.50	.05	.50	.50
Shade-Thin-T05-R70	.05	.70	.70	.05	.70	.70
Shade-Thin-T05-R90	.05	.90	.90	.05	.90	.90
Shade-Thin-T10-R10	.10	.10	.10	.10	.10	.10
Shade-Thin-T10-R30	.10	.30	.30	.10	.30	.30
Shade-Thin-T10-R50	.10	.50	.50	.10	.50	.50
Shade-Thin-T10-R70	.10	.70	.70	.10	.70	.70
Shade-Thin-T10-R80	.10	.80	.80	.10	.80	.80
Shade-Thin-T20-R10	.20	.10	.10	.20	.10	.10
Shade-Thin-T20-R30	.20	.30	.30	.20	.30	.30
Shade-Thin-T20-R50	.20	.50	.50	.20	.50	.50
Shade-Thin-T20-R70	.20	.70	.70	.20	.70	.70
Shade-Thin-T30-R30	.30	.30	.30	.30	.30	.30
Shade-Thin-T30-R50	.30	.50	.50	.30	.50	.50
Shade-Thin-T30-R60	.30	.60	.60	.30	.60	.60

Key:

Tsol = TRANS-SOL-BH

Tvis = TRANS-VIS-BH

Rfsol = REFL-SOL-BH

Rfvis = REFL-VIS-BH

Rbsol = BACKREFL-SOL-BH

Rbvis = BACKREFL-VIS-BH

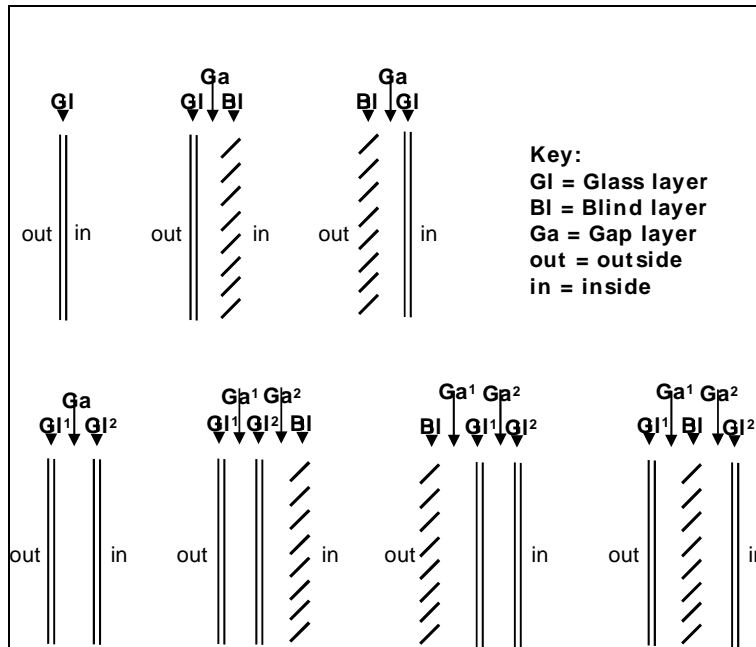

Figure 25 Example Layer Configurations for Single and Double-glazed Windows with and without Blinds

Setbacks, Fins and Overhangs

Shading features local to the window can be specified. These features include setbacks, fins and overhangs. The keywords which specify these local shade devices are positioned with respect to the glazed part of a window and shade the window. The fin and overhang keywords refer to Figure 26. Additionally the shading model for each window can have its level of detail, in terms of the number of calculation elements or divisions, specified.

SETBACK

Distance that the window is recessed into the wall; i.e., the distance from the outside surface of the wall to the outside surface of the window glass. If a window has a frame, the frame is also set back.

OVERHANG-A, OVERHANG-B, OVERHANG-W, OVERHANG-D

Even though overhangs and/or fins are specified under the WINDOW command, these shading surfaces are attached to the wall where the window is located and thus shade both the window and the wall. Also, if this WINDOW is referred to in another WINDOW command with the LIKE keyword, the attached shades are also copied. Note that overhangs and fins are assumed to be opaque. Non-opaque shades can be specified with the BUILDING-SHADE and FIXED-SHADE commands. Unused for interior windows.

Note: For overhang shading calculations to be performed, both OVERHANG-W and OVERHANG-D must be specified. If either of them is specified, but not both, a WARNING message is printed and overhang shading is not performed. If not specified, shading calculations will not be done.

OVERHANG-ANGLE

Is the angle between the overhang and the window. When set at 90, the overhang is perpendicular to the window. If less than 90 it is tilted down; if greater than 90, it is tilted up.

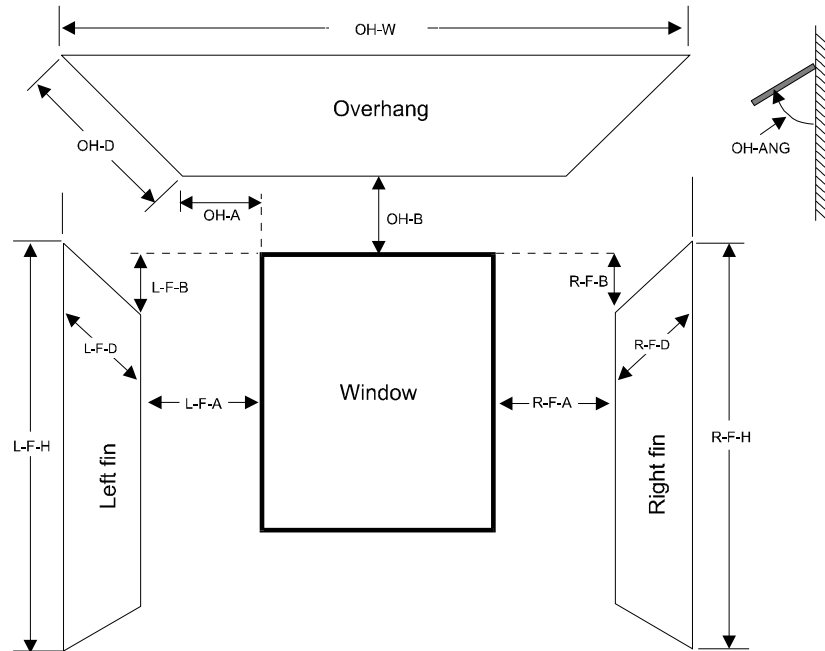

Figure 26 Positioning of overhang and fins with respect to a window
 (The values in this figure are all positive. If the value of L-F-B is input as a negative, the left fin will originate at a point above the top edge of the window; similarly for R-F-B. If OH-A is input as negative, the overhang will originate to the right of the left side of the window)

LEFT-FIN-A, LEFT-FIN-B, LEFT-FIN-H, LEFT-FIN-D

Specify the location and dimensions of a fin to the left of the window. Note: either both LEFT-FIN-H and LEFT-FIN-D or neither should be specified. If not specified, shading calculations will not be done. Unused for interior windows.

RIGHT-FIN-A, RIGHT-FIN-B, RIGHT-FIN-H, RIGHT-FIN-D

Specify the location and dimensions of a fin to the right of the window. Note: either both RIGHT-FIN-H and RIGHT-FIN-D or neither should be specified. If not specified, shading calculations will not be done.

SHADING-DIVISION

An integer value that specifies the number of divisions into which the window is to be segmented for the shading calculation. Not used for interior windows. The larger the number of shading divisions, the longer times the shading computations will require; however, the results will be more exact. If the estimated effect of the shading on the overall building load is large, use more (20 to 40) divisions. If the estimated effect of the shading on the overall building load is small, use fewer (1-10) divisions.

Window Coverings

The following keywords can be used to model window coverings like drapes, screens, and pull-down shades. These keywords should not be used for slat-type shades (blinds). Instead, use WIN-SPEC-METHOD=WINDOW-LAYERS and explicitly enter a blind layer (see WINDOW-LAYER command).

Example input: Window glazing has a visible transmittance of 0.83. Operable drapes have a visible transmittance multiplier² of 0.35, a solar gain multiplier³ of 0.25, and a conductance multiplier⁴ of 0.85. The drapes will be closed when incident solar radiation exceeds 30 Btu/ft²-hr (94.6 W/m²):

```

SC-MULT-1 = SCHEDULE
  TYPE           = MULTIPLIER
  THRU DEC 31    (ALL)(1,24)(0.25) ..

TVIS-SCH-1 = SCHEDULE
  TYPE           = MULTIPLIER
  THRU DEC 31    (ALL)(1,24)(0.35) ..

COND-MULT-1 = SCHEDULE
  TYPE           = MULTIPLIER
  THRU DEC 31    (ALL)(1,24)(0.85) ..

SOL-SCH-1 = SCHEDULE
  TYPE           = RADIATION
  THRU DEC 31    (ALL)(1,24)(30) ..
  . . . .

GT-1 = GLASS-TYPE
  GLASS-TYPE-CODE = 2000 ..
  . . . .

SP-1 = SPACE
  DAYLIGHTING     = YES
  . . . .

WIN-1 = WINDOW
  GLASS-TYPE      = GT-1
  WIN-SHADE-TYPE  = MOVABLE-INTERIOR
  VIS-TRANS-SCH   = TVIS-SCH-1
  MAX-SOLAR-SCH   = SOL-SCH-1
  SHADING-SCH     = SC-MULT-1
  CONDUCT-SCH     = COND-MULT-1
  . . . .
    
```

SHADING-SCHEDULE

Takes the U-name of a SCHEDULE (with TYPE=MULTIPLIER) that defines hourly values of a multiplier on the solar gain through the window. This represents the shading effect of movable devices such as blinds, drapes, or shutters. Items that change solar transmission may also affect heat conduction. If so, a matching CONDUCT-SCHEDULE should be used. If the SHADING-SCHEDULE is not input, the schedule will default to 1.0 for all hours.

WIN-SHADE-TYPE

Takes a code-word giving the type of shading device when a shading device is present on the window for sun and/or glare control. If SHADING-SCHEDULE is not assigned to a window, the window will be considered to have no shading device and WIN-SHADE-TYPE will be ignored.

- MOVABLE-INTERIOR (the default) interior shade that can be retracted, such as drapes or Venetian blinds.
- MOVABLE-EXTERIOR exterior shade that can be retracted.
- FIXED-INTERIOR interior shade that cannot be retracted.
- FIXED-EXTERIOR exterior shade that cannot be retracted.

CONDUCT-SCHEDULE

Takes the U-name of a SCHEDULE (with TYPE=MULTIPLIER) that defines hourly values of a multiplier on the heat conduction through the window. The multiplier values in the SCHEDULE should be ≤ 1.0 . This represents the effect of movable devices such as blinds, insulating drapes, or shutters. If these devices are present, a matching SHADING-SCHEDULE should be specified. If CONDUCT-SCHEDULE is not input, the schedule value will default to 1.0 for all hours.

CONDUCT-TMIN-SCH

Takes the U-name of a SCHEDULE (of TYPE=TEMPERATURE) of values of outside dry-bulb temperature below which movable insulation is deployed on a window. If CONDUCT-TMIN-SCH is specified, a corresponding SHADING-SCHEDULE and CONDUCT-SCHEDULE should also be assigned to the window.

MAX-SOLAR-SCH

Takes the U-name of a schedule (TYPE=RADIATION) of values of solar radiation (in Btu/ft²-hr or W/m²) either incident on the outside of the window or transmitted through the window. The actual hourly value to be used is selected by the value of the [MAX-SOLAR-CTRL](#) keyword.. (This is a change from previous DOE-2 program versions, where in 2.1E the transmitted direct solar radiation was used, and in 2.2, prior to version 44d2, the outside incident total solar radiation was used) The schedule must be of TYPE=RADIATION. The solar radiation used by the calculation logic is either the incident direct (plus optionally the diffuse) radiation after shading by overhangs, fins or detached shading surfaces, or this incident value multiplied by the specified or hourly calculated angular transmittance of the window (and shading coefficient, if appropriate based on the glass specification method.) The program will automatically deploy a shading device whenever the selected solar radiation value, without the shading device, exceeds the schedule value. The shading device will be retracted if the solar radiation value falls below the schedule value. For example, the shades will be deployed if the solar value is 50 Btu/ft²-hr and the schedule value is 20 Btu/ft²-hr (as long as the corresponding SHADING-SCHEDULE value is 1). If MAX-SOLAR-SCH is specified, a corresponding SHADING-SCHEDULE (and CONDUCT-SCHEDULE if desired) should be assigned to the window. The SHADING-SCHEDULE and CONDUCT-SCHEDULE values will only take effect during hours when the shading device is deployed.

MAX-SOLAR-CTRL

Takes a code-word that specifies the variable to be used as the quantity to decide if the shade is closed. The hourly value of the variable specified is used in the comparison with the hourly value of the [MAX-SOLAR-SCH](#) in the logic to decide if the shade is open or closed. The value used is the average value for the entire window as selected from the list below; this value is calculated by multiplying the solar radiation intensity by the fraction of the window that is shaded. The transmitted solar radiation value is calculated as the product of the incident value, the hourly calculated angular transmittance of the window, and, if appropriate based on the window specification method, the shading coefficient of the window.

INCIDENT-DIRECT	The direct solar radiation incident on the outside surface of the window is used as the control variable. This was the default value in DOE-2.2 prior to version 44d2.
INCIDENT-TOTAL	The total (direct plus diffuse) solar radiation incident on the outside surface of the window is used as the control variable.
TRANSMITTED-DIRECT	The direct solar radiation transmitted through the window is used as the control variable. This was the default value in DOE-2.1E
TRANSMITTED- TOTAL	The total (direct plus diffuse) solar radiation transmitted through the window is used as the control variable. This is the default value as of DOE-2.2 version 44d2.

SUN-CTRL-PROB

May be specified if the sun control device on a window is manually operated. Gives the probability that the occupants of a space will deploy the shading device if the incident solar radiation exceeds the [MAX-SOLAR-SCH](#) value. Keyword can be used with or without daylighting.

OPEN-SHADE-SCH

Takes the U-name of a schedule (of TYPE=MULTIPLIER) whose value in any given hour is the probability that the shading device will be opened if both the incident solar radiation and the glare (with shade open) fall below the limits set by MAX-SOLAR-SCH in the WINDOW command and MAX-GLARE in the SPACE command. If OPEN-SHADE-SCH is not specified, the shading devices will be reopened as soon as both the solar radiation and glare fall below the specified limits. The shading devices are reopened at midnight in any case. Unused for interior windows

SOL-TRANS-SCH

Takes the U-name of a SCHEDULE (TYPE=MULTIPLIER) that gives the solar transmittance of a window shading device when it covers the window. Used only for exterior windows in a sunspace. The program multiplies the schedule value by the direct and diffuse solar radiation striking the shade to determine the hourly amount of (diffuse) solar radiation transmitted by the shade. The value of SOL-TRANS-SCH in a given hour must not exceed the corresponding SHADING-SCHEDULE value. If it does, the program will reset it equal to the SHADING-SCHEDULE value. WIN-SHADE-TYPE = FIXED-EXTERIOR or MOVABLE-EXTERIOR should be entered if a sunspace exterior window has a shading device on the outside of the window; otherwise, the program will assume the shade is on the inside. See "Sunspaces" in the *DOE-2.2 Topics*.

VIS-TRANS-SCH

Takes the U-name of a schedule (of TYPE=MULTIPLIER) that gives the daylight transmittance of the window shading device when it covers the window; required for daylighting calculation if SHADING-SCHEDULE is specified. (If WIN-SHADE-TYPE = MOVABLE-INTERIOR or MOVABLE-EXTERIOR, the program will use a transmittance multiplier value of 1.0 when the shade is retracted.) Typical visible transmittance values for translucent drapes and shades are given in Table 39. A transmittance schedule is used, rather than a single fixed value, to allow seasonal change in the transmittance of the shading device. This schedule is used only for windows in a space with DAYLIGHTING = YES. For these windows, be sure to specify not only VIS-TRANS-SCH, but also SHADING-SCHEDULE (and CONDUCT-SCHEDULE if the change in window conductance with the shade in place is significant). In the daylighting calculation, shading surfaces are modeled as perfect diffusers with a daylight transmittance that is independent of angle of incidence. For this reason, slat-type devices, such as Venetian blinds, whose transmittance is a strong function of the angle at which light enters the device, should be modeled as a blind layer (see WINDOW-LAYERS keyword, above, and WINDOW-LAYER command).

Table 39
Daylight transmittance of different window shading devices

Window Shading Device	Daylight transmittance (value of VIS-TRANS-SCH)
<i>Translucent Drapes^a</i>	
Light (white)	0.35
Medium (gray)	0.23
Dark (tan)	0.14
<i>Translucent Shades^b</i>	
Glossy White	0.18
Flat White	0.23
^a C.W. Pennington, et.al, "Experimental Analysis of Solar Heat Gain Through Insulating Glass with Indoor Shading" ASHRAE Journal, February 1964. ^b R.C. Jordan and J.L. Threlkeld, "Determination of the Effectiveness of Window Shading Materials on the Reduction of Solar Radiation Heat Gain" ASHRAE Transactions, Volume 65, 1959.	

GLARE-CTRL-PROB

May be specified if manual operation of a window shading device for glare control is desired. Gives the probability that the occupants of a space will deploy a shading device when the MAX-GLARE value is exceeded (see SPACE). Unused for interior windows. This is a daylighting keyword; see "Daylighting" in the *DOE-2.2 Topics*.

Window Frames and Skylight Curbs

For glazing's in an EXTERIOR-WALL, the following keywords are used to describe a frame around a window, and the curb under the frame of a skylight.. Frames and curbs cannot be specified for windows in sunspace INTERIOR-WALLS.

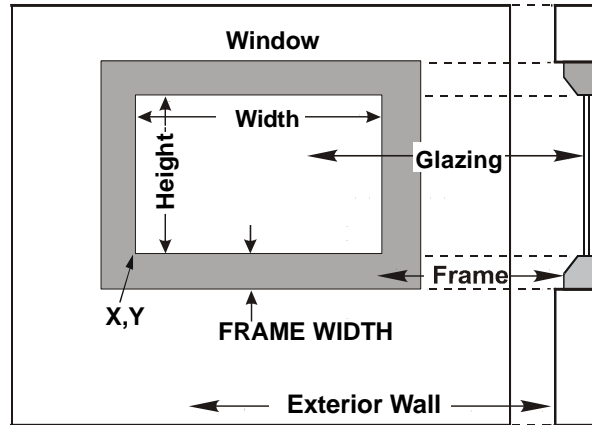

Figure 27 The dimensioning of a window with a frame.
 (The WINDOW keywords X and Y, which indicate the position of the window on the wall, refer to the lower left corner of the glazed portion, not the lower left corner of the frame)

FRAME-WIDTH

Projected width of the frame in the plane of the glazing (Figure 27). We recommend that frames be entered only if the frame area is more than 10 percent or so of the glazed area, which is generally only the case in residential applications. The program assumes that the frame width is the same on all sides of the window. If this is not the case, use the average frame width.

FRAME-ABS

The solar absorptance of the outside surface of the frame.

FRAME-CONDUCT

Conductance of the frame, excluding the outside air film but including the inside air film. Values for typical frame constructions are shown in Table 40.

Table 40
 Conductance of Typical Frame Constructions
 Btu/ft²-F-h (W/m²-K)

Frame Type	FRAME-CONDUCT (excludes OA film)	U-value ^a
Thermally unbroken aluminum	3.037 (17.24)	1.90 (10.79)
Thermally broken aluminum	1.245 (7.07)	1.00 (5.68)
External flush glazed aluminum	0.812 (4.61)	0.70 (3.97)
Wood with or without cladding	0.434 (2.46)	0.40 (2.27)
Vinyl	0.319 (1.81)	0.30 (1.70)

^a U-value includes OA film at 15 mph [6.7 m/s] windspeed
 FRAME-CONDUCT = [(U-value)-1 - 0.197]-1 Btu/ft²-F-h
 FRAME-CONDUCT = [(U-value)-1 - 0.035]-1 W/m²-K

CURB-HEIGHT

The height of the skylight curb perpendicular to the plane of the glazing, displacing a skylight frame and glazing above the roof surface. The program assumes that the curb height is the same on all sides of the skylight. If this is not the case, use the average curb height.

CURB -ABS

The solar absorptance of the outside surface of a skylight curb.

CURB -CONDUCT

Conductance of the skylight curb, excluding the outside air film but including the inside air film.

Notes:

You can define frames and curbs only for exterior windows and skylights, not for interior windows.

The program will do a frame calculation only if you enter FRAME-WIDTH. Otherwise, the frame area will be zero. If the CURB-HEIGHT is zero no curb calculations will be performed.

The program automatically removes the overall window area, including frame (but not the curb), from the associated exterior wall area.

The conductances in Table 40 are effective values that take two-dimensional conduction effects into account.

Each hour, the program adds the effect of a wind speed-dependent outside air film to the user specified FRAME-CONDUCT and CURB-CONDUCT.

If a window has dividers (such as mullions or muntins), then HEIGHT, WIDTH, and FRAME-WIDTH should be chosen so that

$$(\text{HEIGHT}) \times (\text{WIDTH}) = \text{total area of the glazed parts of the window;}$$

and

$$[\text{HEIGHT} + 2 \times (\text{FRAME-WIDTH})] \times [\text{WIDTH} + 2 \times (\text{FRAME-WIDTH})] \\ - (\text{HEIGHT}) \times (\text{WIDTH}) = \text{total area of frame (perimeter plus dividers)}$$

The various elements of a frame or curb (top, bottom, side, dividers, etc.) may have different conductances. In this case, FRAME-CONDUCT and CURB-CONDUCT should be an area-weighted average of the different elements.

The program finds the overall window conduction by adding curb, frame, edge-of-glass, and center-of-glass contributions. Thus, all three of these contributions are included in each of the following report quantities:

"Window Conduction" in summary reports LS-B, LS-C, LS-E, and LS-F;

"Window U-Value" and "Window Area" in verification report LV-D and LV-H;

WINDOW hourly report variable #1, "Window U-Value".

WINDOW multipliers also multiply the frame and curb areas.

Window fins and overhangs shade the frame and curb as well as the glazing.

Shading devices, like blinds and drapes, that you specify using the WINDOW keywords SHADING-SCHEDULE and CONDUCT-SCHEDULE, affect only the glazed part of the window. They do not affect the heat conduction through the frame or curb.

If the window has a setback, the frame and curb are also set back by the same amount.

Example input: The glazed part of a window is 3 ft wide and 4 ft high. The glazing is double-pane low-E with 6-mm glass thickness and argon gas fill (GLASS-TYPE-CODE = 2635). The frame is 3 in (0.25 ft) wide on all sides and has an absorptivity of 0.8 and a conductance, excluding outside air flow, of 0.6 Btu/ft²-hr-F.

```
WIN-1 = WINDOW
GLASS-TYPE      = GT-1
HEIGHT          = 4.0
WIDTH           = 3.0
FRAME-WIDTH     = 0.25
FRAME-ABS       = 0.8
FRAME-CONDUCT   = 0.6 ..
```

SPACER-TYPE

Takes a code-word that specifies the type of pane-to-pane spacer air in multi-pane windows. The type of SPACER affects the edge-of-glass conductance.

ALUMINUM	Aluminum spacer
BUTYL/METAL	Butyl/Metal spacer
INSULATED	Insulated spacer
STEEL	Steel spacer
UE-EQ-UC	Fictitious spacer that gives an edge-of-glass conductance equal to the center-of-glass conductance (i.e., conductance of glass is uniform over its area).

INF-COEF

Specifies an infiltration flow coefficient used to compute the infiltration resulting from cracks around the window frame. Not used for interior windows. This entry is required if the crack method (INF-METHOD = CRACK) is specified in SPACE

The following equation is used to determine infiltration:

$$cfm = (INF - COEF) * (P_w)^{0.66} * L$$

where

L = window perimeter (ft)

Typical values for INF-COEF are:

Construction	INF-COEF
1/8-in crack (0.3 cfm/ft)	1.342
1/4-in crack (0.5 cfm/ft)	2.236
1/2-in crack (1.1 cfm/ft)	4.919

Window Blind Control

The following keywords are used to control slat-type window blinds. They apply only if WIN-SPEC-METHOD=LAYERS-INPUT and one of the layers is a blind. See WINDOW-LAYERS keyword, above, and WINDOW-LAYER command.

BLIND-ADJ-TYPE

Takes a code-word that indicates how the blind coverage (the fraction of the window covered by a blind) is adjusted if a blind is present.

NONE	There is no adjustment; the blind coverage is fixed at the value of BLIND-COVER in the blind's WINDOW-LAYER command.
SCHEDULE	The blind coverage varies according to a user-defined schedule given by BLIND-SCHEDULE.
SOLAR-INTENSITY	If the direct plus diffuse solar radiation incident on the window exceeds the value given by BLIND-TRIGG-SCH, the blind coverage is set to the value of BLIND-COVER-MAX in the blind's WINDOW-LAYER command. Otherwise, the blind coverage stays at BLIND-COVER.
ROOM-TEMP	If the room temperature at the beginning of the hour exceeds the value given by BLIND-TRIGG-SCH, the blind coverage is set to the value of BLIND-COVER-MAX in the blind's WINDOW-LAYER command. Otherwise, the blind coverage stays at BLIND-COVER. <i>[FOR FUTURE IMPLEMENTATION]</i>

BLIND-SCHEDULE

Takes the U-name of a schedule that adjusts the blind coverage between the values of BLIND-COVER-MIN and BLIND-COVER-MAX in the blind's WINDOW-LAYER command. This schedule is used only if BLIND-ADJ-TYPE = SCHEDULE. It should have TYPE = FRACTION. A schedule value of f , which should be between 0.0 and 1.0, gives

$$\text{blind coverage} = f * [\text{BLIND-COVER-MAX}] + (1-f) * [\text{BLIND-COVER-MIN}]$$

BLIND-TRIGG-SCH

Takes the U-name of a schedule of solar intensity values (if BLIND-ADJ-TYPE = SOLAR-INTENSITY) or room temperature values (if BLIND-ADJ-TYPE = ROOM-TEMP) that are used to adjust blind coverage. For solar intensity, the schedule should have TYPE = RADIATION and the schedule value should be the sum of direct plus diffuse solar radiation incident on the window (after shading by overhangs and other obstructions) per unit window area (Btuh/ft² or W/m²). For room temperature, the schedule should have TYPE = TEMPERATURE and the schedule value should be in °F or °C.

SLAT-ADJ-TYPE

Takes a code-word indicating how the slat angle is adjusted if a blind is present.

NONE	There is no adjustment; the slat angle is fixed at the value of SLAT-ANGLE in the blind's WINDOW-LAYER command.
SCHEDULE	The slat angle varies according to a user-defined schedule given by SLAT-SCHEDULE, below.
SOLAR-INTENSITY	If the direct plus diffuse solar radiation incident on the window exceeds the value given by SLAT-TRIGG-SCH, then:

The slat angle is adjusted to a value that just blocks direct sun if the sun is in front of the window and SLAT-SEPARATION is less than or equal to SLAT-WIDTH (the usual case).°F

If the sun is in front of the window but SLAT-SEPARATION is greater than SLAT-WIDTH, then the sun cannot be fully blocked and the slat angle is set to 90o, which maximizes blockage.

If the sun is in back of the window, the slat angle is set to SLAT-ANGLE.

The above adjustments are made even on overcast days when there is no direct sun.

ROOM-TEMP

If the room temperature at the beginning of the hour exceeds the value given by SLAT-TRIGG-SCH, then the slat angle is adjusted as described for SOLAR-INTENSITY. *[FOR FUTURE IMPLEMENTATION]*

SLAT-SCHEDULE

Takes the U-name of a schedule that adjusts the slat angle to a fraction of SLAT-ANGLE-MAX or SLAT-ANGLE-MIN. This schedule is used only if SLAT-ADJ-TYPE = SCHEDULE. A schedule value of f gives

$$\text{slat angle} = f * [\text{SLAT-ANGLE-MAX}], \text{ if } f \geq 0$$

$$\text{slat angle} = f * [\text{SLAT-ANGLE-MIN}], \text{ if } f \leq 0$$

The schedule should have TYPE = FRACTION if only positive values of f are used, in which case f should be between 0 and 1. If positive and negative values of f are used then the schedule should have TYPE = EXP-FRACTION, in which case f should be between -1 and 1.

SLAT-TRIGG-SCH

Takes the U-name of a schedule of solar intensity values (if SLAT-ADJ-TYPE = SOLAR-INTENSITY) or room temperature values (if SLAT-ADJ-TYPE = ROOM-TEMP) that are used to adjust the slat angle. For solar intensity, the schedule should have TYPE = RADIATION and the schedule value should be the sum of direct plus diffuse solar radiation incident on the window (after shading by overhangs and other obstructions) per unit window area (Btuh/h-ft² or W/m²). For room temperature, the schedule should have TYPE = TEMPERATURE and the schedule value should be a temperature (°F or °C).

Switchable Glazing

The following keywords apply to switchable glazing. This is glazing whose transmittance and/or reflectance varies actively or passively according to ambient conditions such as temperature or solar radiation. An example is electrochromic glazing, whose transmittance and reflectance are controlled by a voltage. Only exterior windows can have switchable glazing. See "Switchable Glazing" in the *DOE-2.2 Topics*.

GLASS-TYPE-SW

Takes the U-name of the glass type for the fully-switched (lower transmittance) state. GLASS-TYPE takes the U-name of the corresponding unswitched (higher transmittance) state. An error will result if GLASS-TYPE and GLASS-TYPE-SW have a different number of glass layers.

For electrochromic glazing, GLASS-TYPE and GLASS-TYPE-SW must be chosen from the Library (see "Window Library," in *DOE-2.2 Libraries & Reports*). These electrochromic glass types have GLASS-TYPE-CODE = 28MN, where MN = 01, 02, etc.

SWITCH-CONTROL

Accepts a code-word that specifies the control variable for switching. This keyword is used only for switchable glazing in exterior windows. The choices are as follows:

NO-SWITCH	No switching, the default.
DIR-SOL-INC	Intensity of direct solar incident on the glazing, after shading by overhangs, setback, neighboring buildings, etc.
TOT-SOL-INC	Intensity of total (direct plus diffuse) solar incident on the glazing, after shading by overhangs, setback, neighboring buildings, etc.
DIR-SOL-TR	Intensity of direct solar radiation transmitted by the glazing in the unswitched state.
TOT-SOL-TR	Intensity of total (direct plus diffuse) solar radiation transmitted by the glazing in the unswitched state (Btu/h-ft ² [glass]).
TOT-SOL-HOR	Intensity of total (direct plus diffuse) solar radiation incident on an unobstructed Horizontal plane.
OUTSIDE-TEMP	Outside dry-bulb temperature.
SPACE-LOAD	Previous-hour thermal load per unit of floor area for the space that contains the window (Btu/h-ft ² [floor]). Note that cooling loads are positive and heating loads are negative. Switching control based on space load should be modeled only if the actual space temperature for hours that the control is in effect is within a few degrees of the LOADS calculation temperature (as given by the TEMPERATURE keyword in SPACE).
DAYLIGHT-LEVEL	Interior daylight illuminance level. The visible transmittance of the glazing is adjusted continuously between the values corresponding to the WINDOW keywords GLASS-TYPE and GLASS-TYPE-SW in order to provide a daylight illuminance that is as close as possible to the illuminance setpoint at the first daylighting reference point. The solar properties of the glazing are adjusted accordingly. For this control option, the visible transmittance (at normal incidence) for GLASS-TYPE should be greater than that for GLASS-TYPE-SW, otherwise an error message will result.

For rooms with a single window wall, if you locate the reference point close to the window, where the daylight illuminance is high, it is likely that, after the electrochromic adjusts, the daylight illuminance at the back of the room will be too low. For this reason, we recommend that you locate the reference point on the window centerline at about two-thirds of the room depth from the window. For rooms with two reference points, we recommend that the second reference point be located about one-third of the room depth from the window. This arrangement should give close to optimal utilization of available daylight.

SWITCH-SET-HI

The upper setpoint value for the switching control variable specified by SWITCH-CONTROL (see Figure 28). Unused if SWITCH-CONTROL = DAYLIGHT-LEVEL. SWITCH-SET-HI should be greater than or equal to SWITCH-SET-LO. The units for SWITCH-SET-HI are given in Table 41 and by the code-word you assigned to SWITCH-CONTROL. For example, if SWITCH-CONTROL=TOT-SOL-INC, the unit is Btu/ft2-h. Even in metric runs, English units should be used.

Table 41
Units of SWITCH-SET-HI and -LO

SWITCH-CONTROL	Energy Units
DIR-SOL-INC	Btu/h-ft2 [glass]
TOT-SOL-INC	Btu/h-ft2 [glass]
DIR-SOL-TR	Btu/h-ft2 [glass]
TOT-SOL-TR	Btu/h-ft2 [glass]
TOT-SOL-HOR	Btu/h-ft2
OUTSIDE-TEMP	°F
SPACE-LOAD	Btu/h-ft2 [floor]

SWITCH-SET-LO

The lower setpoint value for the switching control variable specified by SWITCH-CONTROL. Unused if SWITCH-CONTROL = DAYLIGHT-LEVEL. See Table 41 for units. Even in metric runs, English units should be used.

Notes on switchable glazing:

If there is more than one window in a space, some may have switching control and others not. For example, skylights might be controlled and view windows not. Also, multiple windows in a space can have different control types.

Switchable control does not work for interior windows; is applicable only to exterior windows (windows in EXTERIOR-WALLs).

Switching control is in effect only during sun-up hours; it doesn't work at night. Don't use switchable glazing to switch between window U-values; use the WINDOW keyword CONDUCT-TMIN-SCH instead.

Shading devices such as blinds and drapes (as specified with WINDOW keywords SHADING-SCHEDULE, VIS-TRANS-SCH, etc.) can be used in conjunction with switching control of the glazing. In this case, the program decides what state the glazing should be switched to, ignoring the possible presence of shading devices, and then adjusts the solar intensity through the switched glazing for the presence of the shading device.

SWITCH-SCH

Takes the U-name of a schedule (of TYPE=ON/OFF) that specifies when switching is allowed (schedule value = 1) and not allowed (schedule value = 0). This schedule allows switching to be disabled at times of the day or year when it might be disadvantageous. If SWITCH-SCH is not entered, the program will assume that switching is allowed all the time.

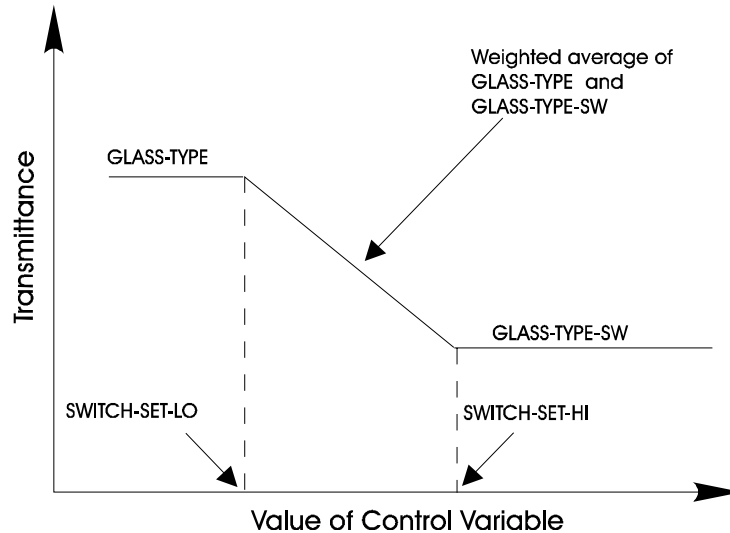

Figure 28 Control Action for Switchable Glazing
(Glass properties such as solar and visible transmittance depend on the value of a user-specified variable)

Miscellaneous Window Keywords

GND-FORM-FACTOR

Fraction of the hemisphere facing the window that is subtended by the ground, adjacent buildings, trees, hills, etc. GND-FORM-FACTOR and SKY-FORM-FACTOR are used in the diffuse radiation calculation. Either both or neither of these keywords should be specified. If not specified, the program will calculate them. These values are used in the diffuse shading calculation for the window.

SKY-FORM-FACTOR

Fraction of the hemisphere facing the window that is subtended by the open sky. See note under keyword GND-FORM-FACTOR.

CONVERGENCE-TOL

Convergence tolerance for conduction calculation for windows from the Library. This calculation will be a few percent more accurate if specified. This invokes a time-consuming iterative calculation that converges when, for each glass layer, the temperature difference between successive iterations is less than CONVERGENCE-TOL. Because of the increase in calculation time, CONVERGENCE-TOL should only be used for research applications. If CONVERGENCE-TOL is not specified, the glazing U-value is based on glass layer temperatures that are equally spaced between outside and inside air temperature.

Input Functions

FUNCTION

Invokes a function calculation for this window. Unused for interior windows. See FUNCTION command. See also "Input Functions" in the *DOE-2.2 Topics*.

WINDOW-SPEC-FN

Special function used in LOADS subroutines CALWIN, DCOF, DINTIL, and DREFLT. The function is used to alter variables involved in the daylighting calculation. WINDOW-SPEC-FN takes only one U-name, surrounded by asterisks, but without parentheses. Unused for interior windows.

Example input:

WINDOW-SPEC-FN = *WINFN-1*

WINDOW-LAYER

This command, and the associated WINDOW-LAYERS keyword in the WINDOW command, are used when you want to build up a window from layers, much as a wall can be built up from layers. Three types of window layer are allowed: glass, gap and blind. For example, a single-glazed window with no covering would have only a glass layer. A double-glazed window would have three layers: two glass layers separated by a gap of air or other gas. A single-glazed window with a blind would also have three layers: a glass layer and a blind layer separated by a gap. The WINDOW-LAYER command allows you to specify the type and properties of a layer.

U-name is required. To specify the set of one or more layers that comprise a window, you assign a list of WINDOW-LAYER U-names to the WINDOW-LAYERS keyword in the WINDOW command.

The program calculates the overall thermal and solar-optical properties of a window from the individual layer properties and the order of the layers in the window. Accounted for are the layer-to-layer interreflection of solar, visible and IR radiation and the dependence of transmittance, absorptance, and reflectance on the angle of incidence of solar and visible radiation on the window. For blind layers, the program accounts for the effect on transmittance of slat angle and other slat properties.

Table 42 shows all of the WINDOW-LAYER keywords and their default values by layer type.

In the following:

For a glass or gap layer, "front" means the outside of the layer (the side facing outdoors). For a horizontal blind in a vertical window, "front" means the side of the slat that faces up when the blind is fully open. For vertical blinds in a vertical window, "front" means the side of the slat that faces to the right when you look at the blind from the outside of the window and the blind is fully open.

For a glass or gap layer, "back" means the inside of a layer (the side facing the room). For a blind layer, "back" means the side of the slat that faces indoors when the slat points downwards (SLAT-ANGLE > 0).

"Solar" means the full spectrum of radiation from the sun

"Visible" means the visible part of radiation from the sun

"Beam" means direct radiation

"Hemispherical" means diffuse radiation

Table 42 Window-layer keywords

Keyword	Default Value by Layer-Type		
	GLASS	BLIND	GAP
BACKEMIS-IR	0.84	0.9	not used
BACKREFL-SOL-BB	0.071	not used	not used
BACKREFL-SOL-BH	not used	0.5	not used
BACKREFL-SOL-HH	not used	0.5	not used
BACKREFL-VIS-BB	0.071	not used	not used
BACKREFL-VIS-BH	not used	0.5	not used
BACKREFL-VIS-HH	not used	0.5	not used
BLIND-COVER	not used	1.0	not used
BLIND-COVER-MAX	not used	1.0	not used
BLIND-COVER-MIN	not used	0.0	not used
CONDUCTIVITY	0.52 Btuh/ft-F (0.9 W/m-K)	0.52 Btuh/ft-F (0.9 W/m-K)	0.00936 Btuh/ft-F (0.0162 W/m-K)
D-CONDUCTIVITY	not used	not used	1.6049 Btuh/ft-R2 x10-5 (5.0 W/m-K2 x10-5)
DENSITY	not used	not used	0.10612 lb/ft3 (1.70 kg/m3)
D-DENSITY	not used	not used	-0.00021 lb/ft3-F (-0.006 kg/m3-K)
PRANDTL-NUMB	not used	not used	0.68
D-PRANDTL-NUMB	not used	not used	0.0003667 F-1 (0.00066 K-1)
D-VISCOSITY	not used	not used	2.352 lb/ft-s-F x10-7 (6.3 kg/m-s-K x10-7)
EMIS-IR	0.84	0.9	not used
REFL-SOL-BB	0.071	not used	not used
REFL-SOL-BH	not used	0.5	not used
REFL-SOL-HH	not used	0.5	not used
REFL-VIS-BB	0.071	not used	not used
REFL-VIS-BH	not used	0.5	not used
REFL-VIS-HH	not used	0.5	not used
SLAT-ANGLE	not used	45 degrees	not used
SLAT-ANGLE-MAX	not used	80 degrees	not used
SLAT-ANGLE-MIN	not used	-80 degrees	not used
SLAT-ORIENTATION	not used	HORIZONTAL	not used
SLAT-SEPARATION	not used	0.0625ft (0.0190m)	not used
SLAT-WIDTH	not used	0.0833ft	not used

Keyword	Default Value by Layer-Type		
	GLASS	BLIND	GAP
	(0.0254m)		
THICKNESS	0.0208ft (0.0063m)	0.00328ft (0.001m)	0.0208ft (0.0063m)
TRANS-IR	0.0	0.0	not used
TRANS-SOL-BB	0.775	0.0	not used
TRANS-SOL-BH	not used	0.0	not used
TRANS-SOL-HH	not used	0.0	not used
TRANS-VIS-BB	0.775	0.0	not used
TRANS-VIS-BH	not used	0.0	not used
TRANS-VIS-HH	not used	0.0	not used
VISCOSITY	not used	not used	1.418 lb/ft-s x10-5 (2.11 kg/m-s x10-5)

Notes:

It is assumed that the radiation transmitted and reflected by the slats in a blind is 100 percent hemispherical.

It is assumed that glass layers have no beam-hemispherical (BH) transmittance or reflectance, so that the BH keywords below apply only to blind layers.

The program calculates the hemispherical-hemispherical (HH) transmittance and reflectance of glass layers from the beam-beam properties. Therefore the hemispherical-hemispherical (HH) keywords below apply only to blind layers.

For blind layers, the keywords apply to the individual slats rather than to the blind layer as a whole.

Slats are assumed to be flat and of uniform width and thickness.

It is assumed that the front and back transmittance for glass and blind layers are equal.

The transmittance and reflectance keywords do not apply to gaps (the gas in gaps is assumed to have 100 percent transmittance and zero reflectance).

TYPE

Takes a code-word indicating the type of layer.

- GLASS is a layer of glass, plastic or other transparent material.
- GAP is a layer of gas, usually air, but possibly argon or other gas, that separates two glass layers or a glass layer and a blind layer.
- BLIND is a slatted shading device such as a venetian blind. The slats may be fixed or movable. A blind can be on the outside of the window, on the inside, or between glass layers.

Solar radiation keywords

TRANS-SOL-BB

For glass or blind layer: Beam-beam transmittance at normal incidence of solar radiation striking the front or back of a glass layer or slat in a blind layer. Although TRANS-SOL-BB can be defined for a blind (in the rare case that the slats are transparent or perforated), the program will calculate the transmitted radiation as diffuse.

REFL-SOL-BB

For glass layer only: Beam-beam reflectance of solar radiation striking the front of the layer at normal incidence.

BACKREFL-SOL-BB

For glass layer only: Beam-beam reflectance of solar radiation striking the back of the layer at normal incidence.

TRANS-SOL-BH

For blind layer only: Beam-hemispherical transmittance of solar radiation striking the front or back of a slat at normal incidence.

REFL-SOL-BH

For blind layer only: Beam-hemispherical reflectance of solar radiation striking the front of a slat at normal incidence.

BACKREFL-SOL-BH

For blind layer only: Beam-hemispherical reflectance of solar radiation striking the back of a slat at normal incidence.

TRANS-SOL-HH

For blind layer only: Hemispherical-hemispherical transmittance of solar radiation striking the front or back of a slat.

REFL-SOL-HH

For blind layer only: Hemispherical-hemispherical reflectance of solar radiation striking the front of a slat.

BACKREFL-SOL-HH

For blind layer only: Hemispherical-hemispherical reflectance of solar radiation striking the back of a slat.

Visible radiation keywords

TRANS-VIS-BB

For glass layer only: Beam-beam transmittance of visible radiation striking the front or back of the layer at normal incidence.

REFL-VIS-BB

For glass layer only: Beam-beam reflectance of visible radiation striking the front of the layer at normal incidence.

BACKREFL-VIS-BB

For glass layer only: Beam-beam reflectance of visible radiation striking the back of the layer at normal incidence.

TRANS-VIS-BH

For blind layer only: Beam-hemispherical transmittance of visible radiation striking the front or back of a slat at normal incidence.

REFL-VIS-BH

For blind layer only: Beam-hemispherical reflectance of visible radiation striking the front of a slat at normal incidence.

BACKREFL-VIS-BH

For blind layer only: Beam-hemispherical reflectance of visible radiation striking the back of a slat at normal incidence.

TRANS-VIS-HH

For blind layer only: Hemispherical-hemispherical transmittance of visible radiation striking the front or back of a slat.

REFL-VIS-HH

For blind layer only: Hemispherical-hemispherical reflectance for visible radiation striking the front of a slat.

BACKREFL-VIS-HH

For blind layer only: Hemispherical-hemispherical reflectance for visible radiation striking the back of a slat.

Infrared radiation keywords (apply only to glass or blind layers)**TRANS-IR**

The infrared transmittance of a glass layer or slat in a blind layer. Assumed independent of angle of incidence.

EMIS-IR

The hemispherical infrared emissivity of the front of a glass layer or the front of a slat in a blind layer.

BACKEMIS-IR

The hemispherical infrared emissivity of the back of a glass layer or the back of a slat in a blind layer.

Slat and blind keywords (apply only to blind layers)**SLAT-ORIENTATION**

Takes a code-word that indicates the orientation of the slats in a blind layer.

HORIZONTAL	indicates that the slats are parallel to the X-axis of the window. For a vertical window, the slats are horizontal (parallel to the ground).
VERTICAL	indicates that the slats are parallel to the Y-axis of the window. For a vertical window, the slats are vertical (perpendicular to the ground).

SLAT-ANGLE

The angle between the plane of the slat and the window outward normal (see Figure 29). For horizontal slats in a vertical window, this is the angle between the slat and a horizontal plane; in this case SLAT-ANGLE is positive when the front of the slat points down and negative when the front of the slat points up. For vertical slats in a vertical window, this is the angle between the front of the slat and vertical plane normal to the window; in this case SLAT-ANGLE is positive when the front of the slat points to the right and negative when the front of the slat points to the left when you are facing the outside of the window.

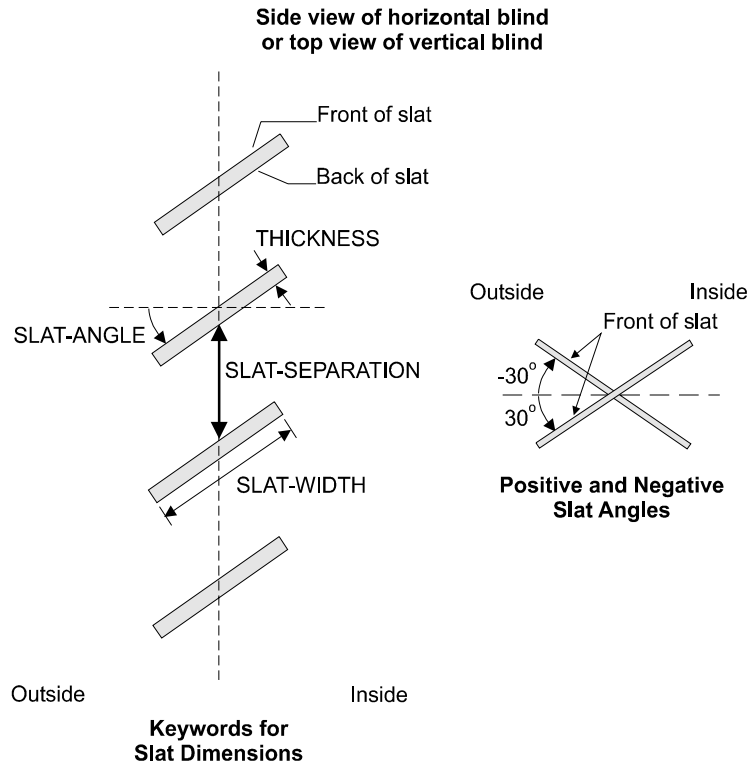

Figure 29 Dimensions for blinds
(Slat angle is the angle between the plane of the slat and the window outward normal)

SLAT-ANGLE-MIN

The minimum slat angle for angle-adjustable slats (due to limitations in the blind construction or control).

SLAT-ANGLE-MAX

The maximum slat angle for angle-adjustable slats (due to limitations in the blind construction or control). SLAT-ANGLE-MAX should be greater than SLAT-ANGLE-MIN.

SLAT-WIDTH

The width of the slat, as shown in Figure 29. The default value corresponds to slats that are 1.0 in wide.

SLAT-SEPARATION

The distance between slats. See Figure 29. The default value corresponds to slats that are 0.75 in apart.

BLIND-COVER

Fraction of the glazed area covered by the blind. Used only when the blind coverage is fixed (i.e., blinds cannot move up and down). It is assumed that a blind, if present, covers all or part of the glazed area of the window. It does not cover any of the framed portion of the window if the window has a frame.

BLIND-COVER-MIN

Minimum fraction of glazed area covered by blind (used when blind coverage is variable). If all of the retracted slats remain over the glazed opening (e.g., there is no recess above the window to accept retracted slats), then BLIND-COVER-MIN should be greater than

$$(\text{THICKNESS} + \delta) / (\text{THICKNESS} + [\text{SLAT-SEPARATION}]),$$

which is the fraction of the window covered by the blind when the blind is fully retracted. (Here, δ is the separation between adjacent slat faces when the blinds are fully retracted.)

BLIND-COVER-MAX

Maximum fraction of window area covered by blind (used when blind coverage is variable). BLIND-COVER-MAX should be greater than BLIND-COVER-MIN.

Keywords for a glass, blind, or gap layer

THICKNESS

The thickness of a glass layer, a gap layer, or the slats in a blind layer. For a glass layer, THICKNESS is the surface-to-surface thickness.

For a gap between two glass layers, THICKNESS is the distance between the inside surface of one glass layer and the outside surface of the other glass layer.

For a gap between a glass layer and a blind layer, THICKNESS is the distance between the center plane of the blinds and the glass surface. In this case, the gap THICKNESS should be greater than SLAT-WIDTH/2 to allow room for the slats when fully open.

For a blind layer, THICKNESS is the surface-to-surface thickness of the slats.

The default thickness for glass and gap corresponds to 1/4 in (6.3 mm) and for blinds corresponds to 0.04 in (1.0 mm).

CONDUCTIVITY

For a glass or gap layer, the conductance of the layer times its THICKNESS. For a blind layer, the conductance of the slat times its THICKNESS.

Gap layer keywords (defaults shown are for argon)

D-CONDUCTIVITY)

The temperature derivative of the conductivity of the gas in the gap.

VISCOSITY

The viscosity of the gas in the gap.

D-VISCOSITY

The temperature derivative of the viscosity of the gas in the gap.

DENSITY

The density of the gas in the gap.

D-DENSITY

The temperature derivative of the density of the gas in the gap

PRANDTL-NUMB

The Prandtl number of the gas in the gap.

D-PRANDTL-NUMB

The temperature derivative of the Prandtl number of the gas.

How to Model Pull-Down Shades

You can model a translucent pull-down shade by entering it as a blind with closed slats in the WINDOW-LAYERS list. In this case, you should not specify SLAT-ADJ-TYPE, SLAT-SCHEDULE, or SLAT-TRIGG-SCH. Shades that are input this way will give a more accurate calculation of solar gain than if modeled using SHADING-SCHEDULE and VIS-TRANS-SCH because inter-reflections between the shade and glass layers are properly taken into account in the calculation.

Table 38 shows the pull-down shade layers that are in the Library. To describe your own pull-down shade layer, your input might look like the following for a shade with a solar and visible transmittance of 20% and a solar and visible reflectance of 70%:

```
Shade-T20-R70 = WINDOW-LAYER
TYPE           = BLIND
THICKNESS      = 0.00066
CONDUCTIVITY   = 0.0667
SLAT-ANGLE     = 89.95
SLAT-ORIENTATION = HORIZONTAL
SLAT-WIDTH     = 0.0840
SLAT-SEPARATION = 0.0833
TRANS-SOL-BH   = 0.20
TRANS-SOL-HH   = 0.20
REFL-SOL-BH    = 0.70
REFL-SOL-HH    = 0.70
BACKREFL-SOL-BH = 0.70
BACKREFL-SOL-HH = 0.70
TRANS-VIS-BH   = 0.20
TRANS-VIS-HH   = 0.20
REFL-VIS-BH    = 0.70
REFL-VIS-HH    = 0.70
BACKREFL-VIS-BH = 0.70
BACKREFL-VIS-HH = 0.70 ..
```

HVAC Components

This section describes the commands and keywords used in the mechanical equipment simulations. Included here are the descriptions for the:

Airside components – These components include the fans, heating/cooling coils, economizers, ducts, terminal units, thermostats, etc. The program simulates both zonal, packaged, and built-up central systems.

Waterside components – These components include the boilers, chillers, pumps, circulation-loops, etc. used to build up a central heating or cooling plant.

Utility components – The program supports multiple electric, fuel, steam, and chilled-water meters, as well as cogeneration equipment.

BOILER

Defines all of the operating parameters of a boiler. The U-name is required to identify the boiler in the heading of the boiler report, as well as to allow this boiler's operation to be coordinated with others.

Example input:

```
BOILER-1 = BOILER
  TYPE           = HW-BOILER
  HW-LOOP        = "HEATING LOOP" . .
```

TYPE

Takes a code-word that specifies the type of boiler. Note that the steam boilers are modeled identically to the hot water boilers, except that their efficiencies are lower. The program currently does not model steam loops, so the effects of flash losses, de-aeration, condensate makeup, etc. should be included in the efficiency term. Allowed values of TYPE are:

HW-BOILER	Hot water boiler.
HW-BOILER-W/DRAFT	Hot water boiler with draft fan.
ELEC-HW-BOILER	Electric hot water boiler.
STM-BOILER	Steam boiler.
STM-BOILER-W/DRAFT	Stream boiler with draft fan.
ELEC-STM-BOILER	Electric steam boiler.

Boiler Design and Operating Capacity

CAPACITY

The nominal (or rated) heating capacity of the boiler. If the capacity is temperature dependent, (curve CAP-FT is specified), the capacity should correspond to the HW-SUPPLY-T and AMBIENT-T.

If you do not specify CAPACITY,

If CAPACITY-RATIO is specified, the capacity defaults to the maximum design-day heating loop capacity, multiplied by the CAPACITY-RATIO.

If no CAPACITY-RATIO is specified, the capacity defaults to the maximum design-day heating loop capacity, divided by the number of boilers attached to the loop, and multiplied by the loop's SIZING-RATIO.

CAPACITY-RATIO

The fraction of the design heating loop capacity that the boiler will be sized to meet. Used only if CAPACITY is not specified. If you are defining two boilers of identical size that exactly meet the design loop load, set each boiler's CAPACITY-RATIO to 0.5. To include a 20% safety factor, set each boiler's CAPACITY-RATIO to 0.6. If no CAPACITY-RATIO is specified, the capacity defaults to the maximum design-day heating loop capacity, divided by the number of boilers attached to the loop, and multiplied by the loop's SIZING-RATIO.

MIN-RATIO

The minimum fraction of rated load at which the boiler can operate continuously. If the load is between zero and MIN-RATIO the boiler will cycle on and off.

MAX-RATIO

The maximum fraction of rated load the boiler is allowed to handle. If the boiler is allowed to overload, MAX-RATIO may be greater than 1.0.

CAPACITY-FT

Takes the U-name of a curve that modifies the boiler capacity as a function of the supply temperature and the boiler's environmental temperature. If not specified, the capacity is assumed constant for all temperature conditions. The supply temperature is the greater of the loop supply setpoint, or the boiler's internal AQUASTAT-SETPT-T. The environmental temperature may be either the outdoor air temperature, or a zone temperature.

START-UP-TIME

If a boiler is to be used in the current hour, but did not operate the previous hour, then a start-up load is assumed to exist. The equivalent full-load run time added to the current hour's load varies according to how many hours the boiler has been shut down:

1 hour:	50% of this value
2 hours	80% of this value
3 or more hours	100% of this value

STANDBY-TIME

The number of hours of equivalent full-load time required to maintain a boiler at temperature, when the heating load is zero. When operating below the MIN-RATIO, the boiler is assumed to be cycling. When cycled on, the boiler will operate at the MIN-RATIO. When off, losses and energy are determined using this keyword. The program interpolates between energy consumed at the MIN-RATIO, and energy in full standby mode; based on the fraction of the time the boiler is cycled on.

Boiler Energy Consumption

The next set of keywords defines the energy consumption of the boiler. Not all keywords are used for every boiler type. For example, an electric boiler does not consume fuel and so does not have an HIR. However, a fuel-fired boiler may have electrical usage, such as for a draft fan, and the electrical consumption of this fan may vary with load. Consequently, the fuel-fired boilers may use both the EIR and HIR set of keywords.

HEAT-INPUT-RATIO

The ratio of fuel heat input to boiler heating capacity at full load (i.e., at the rated conditions). Used only for fuel-consuming boilers. Note that this is a dimensionless ratio, so you must convert fuel consumption and heating capacity to the same units before dividing.

HIR-FT

Takes the U-name of a curve that modifies the fuel consumption as a function of the supply temperature and the environmental temperature. There is no default; if not specified then the HEAT-INPUT-RATIO is assumed constant for all temperature conditions. The supply temperature is the greater of the loop supply setpoint, or the boiler's internal AQUASTAT-SETPT-T. The LOCATION keyword, below, determines whether the environmental temperature is the outdoor air temperature or a zone temperature.

HIR-FPLR

Takes the U-name of a curve that modifies the fuel consumption as a function of the boiler part load ratio.

LOCATION

Accepts a code-word that specifies the location of the boiler:

OUTDOOR	The boiler is located outdoors.
ZONE	The boiler is located within a zone. Note that the program does not model any zonal heat gain from the boiler. See ZONE-NAME keyword.

ZONE-NAME

When LOCATION = ZONE, takes the U-name of the zone containing the boiler. If ZONE-NAME is not specified, LOCATION will default to OUTDOOR.

ELEC-INPUT-RATIO

The ratio of electric input power to nominal boiler capacity. The EIR is dimensionless, so the same units for input and capacity should be used when calculating it. The default is 1.0 for electric boilers (ELEC-HW-BOIL and ELEC-STM-BOIL).

EIR-FPLR

Takes the U-name of a curve that gives the EIR as a function of the boiler part load ratio.

AUX-KW

Auxiliary electrical consumption, such as for a control panel.

AUX-MODE

Accepts a code-word specifying when the AUX-KW is consumed.

ALWAYS	Auxiliary power is consumed all hours.
WHEN-ON	Auxiliary power is consumed only during the hours the boiler is operating.
WHEN-OFF	Auxiliary power is consumed only during the hours the boiler is off.
SCHEDULED	The power consumption is scheduled (see AUX-SCH).

AUX-SCHEDULE

When AUX-MODE = SCHEDULED, takes the U-name of a schedule of TYPE = MULTIPLIER that varies the AUX-KW on an hourly basis.

AUX-METER

Takes the U-name of the AUX-METER to which the auxiliary electricity consumption of the boiler is assigned. This keyword defaults to the same meter as the boiler's ELEC-METER.

ELEC-METER

Takes the U-name of the ELEC-METER to which the electricity consumption of the boiler is assigned. The default is the MASTER-METER:HEAT-ELEC-METER.

FUEL-METER

Takes the U-name of the FUEL-METER to which the fuel consumption of the boiler is assigned. The default is the MASTER-METER:HEAT-FUEL-METER.

Attachment to Hot-Water Loop

The next set of keywords describe how this boiler is attached to a hot-water, WLHP, or steam loop.

HW-LOOP

Takes the U-name of the primary heating loop to which the boiler is attached. The boiler must be attached to a CIRCULATION-LOOP of TYPE = HW, WLHP, or PIPE2.

HW-PUMP

Takes the U-name of the PUMP that serves the boiler's hot water loop. If you do not assign this pump, the boiler head requirement is passed to the attached primary loop. Additionally, this boiler pump may be an equipment-recirculation pump, or, if the hot water loop does not have its own pump, this boiler pump will also power the primary loop. In this case, the head of this pump will be the sum of the maximum coil head, the loop distribution head (including static head), and the boiler head. The hourly flow of the pump (and boiler) will be determined based on the loop flow and the number of other boilers running.

HW-DT

The design temperature change of the hot water through the boiler. The default is the LOOP-DESIGN-DT of the attached loop. The program uses this keyword to determine the boiler's design flow, which in turn is used to size the equipment-recirculation pump, if any, on the boiler, and calculate the hourly pressure drop. If no equipment-recirculation pump exists, the flow through the boiler is based on the LOOP-DESIGN-DT.

HW-HEAD

The head loss through the boiler at design flow.

HW-STATIC-HEAD

The static head of the boiler (non-varying with flow).

HW-FLOW-CTRL

When the boiler has an equipment-recirculation pump, takes a code-word that specifies the type of flow through the boiler.

CONSTANT-FLOW	The default, indicates that the flow is independent of the load. Note that unless a HW-PUMP exists, the flow through the boiler will be dependent on the primary loop flow. For example, if the flow in the primary loop is variable, then the flow through the boiler will also be variable.
---------------	---

VARIABLE-FLOW	The flow varies linearly with the load.
---------------	---

HW-MIN-FLOW

When HW-FLOW-CTRL = VARIABLE-FLOW, specifies the minimum allowable fraction of the design flow through the boiler. Typically, the minimum flow should be above the point where the flow transitions from turbulent to laminar flow.

HW-MAX-FLOW

The ratio of the maximum allowable flow ratio to the design flow ratio. When allocating load to equipment on an hourly basis, the program will check to ensure that the corresponding flow does not exceed this value. If so, the program will re-allocate the load so that the flow limit of any equipment unit is not exceeded.

AQUASTAT-SETPT-T

The setpoint of the boiler's internal aquastat. The effective supply temperature is the larger of this value and the setpoint of the attached heating loop.

Miscellaneous**COST-DATA**

Takes the U-name of a MATERIALS-COST command, which allows you to define first costs, maintenance costs, etc. for the boiler.

EQUIPMENT-REPORTS

Takes the code-words YES or NO. When report PS-H of the PLANT-REPORTS is enabled, a report will print for the boiler unless this keyword is set to NO.

CHILLER

Defines all of the operating parameters of a chiller. U-name must be specified for each chiller. This U-name will be used in the heading of the chiller report to identify the chiller.

Example Input:

```
CHILLER-1 = CHILLER
  TYPE                = ELEC-OPEN-CENT
  CONDENSER-TYPE      = WATER-COOLED
  CHW-LOOP            = "COOLING LOOP"
  CW-LOOP             = "CONDENSER LOOP"
  ..
```

TYPE

Takes a code-word that specifies the type of chiller. It should be the first keyword entered for the CHILLER command. The next keyword entered should be the CONDENSER-TYPE, described below. Allowed values of TYPE are:

ELEC-OPEN-CENT	<p>Open centrifugal chiller powered by an external electric motor. The motor may be either constant-speed or variable-speed.</p> <p>The program includes generic performance data for both water-cooled and air-cooled condensers. The program also supports remote air-cooled and evaporatively cooled condensers, however default performance data does not exist (it will require that you provide performance data for these types).</p>
ELEC-OPEN-REC	<p>Open reciprocating chiller powered by an external electric motor. The program assumes two independent refrigerant circuits; you may specify the number of compressors in each circuit.</p> <p>The program includes generic performance data for water-cooled, air-cooled, remote air-cooled, and remote evaporatively-cooled condensers.</p>
ELEC-HERM-CENT	<p>Hermetic centrifugal chiller powered by an internal electric motor. The motor may be either constant-speed or variable-speed.</p> <p>The program includes generic performance data for both water-cooled and air-cooled condensers. The program also supports remote air-cooled and evaporatively cooled condensers, however default performance data does not exist (it will require that you provide performance data for these types).</p>
ELEC-HERM-REC	<p>Hermetic reciprocating chiller powered by an internal electric motor. The program assumes two independent refrigerant circuits; you may specify the number of compressors in each circuit.</p> <p>The program includes generic performance data for water-cooled, air-cooled, remote air-cooled, and remote evaporatively-cooled condensers.</p>
ELEC-SCREW	<p>Hermetic screw chiller powered by an internal electric motor. The default part load performance curves assume two independent refrigerant circuits; you may specify the number of compressors in each circuit.</p>

	The program includes generic performance data for water-cooled, air-cooled, remote air-cooled, and remote evaporatively-cooled condensers.
ELEC-HTREC	<p>Centrifugal chiller, powered by an internal electric motor, especially designed for heat recovery. This chiller is designed to reject heat at a higher temperature than a conventional chiller (105F [40.6C] instead of 95F [35C]), and may have two condensers, one for heat recovery and one for heat rejection (double-bundle). Because this chiller's impeller has a higher design lift, there is usually an energy penalty associated with this chiller's operation, even when not recovering heat.</p> <p>The program includes generic performance data for a water-cooled condenser. The program also supports air-cooled, remote air-cooled and evaporatively cooled condensers, however default performance data does not exist (it will require that you provide performance data for these types).</p>
ABSOR-1	Single-stage absorption chiller with a water-cooled condenser. May be powered by hot water or steam (although the program does not explicitly model steam loops).
ABSOR-2	Two-stage absorption chiller with a water-cooled condenser. May be powered by high temperature and pressure hot water or steam (although the program does not explicitly model steam loops).
GAS-ABSOR	Direct, gas-fired, two-stage absorption chiller. that can also operate as a hot water generator. This chiller has a water-cooled condenser.
ENGINE	Gas-fired, engine-driven, variable-speed chiller with a water-cooled condenser.
HEAT-PUMP	<p>An air-to-water heat pump, or well-water-to-water heat pump. This chiller serves a two-pipe circulation-loop, and delivers either hot or chilled water as required by the loop.</p> <p>If CONDENSER-TYPE = AIR-COOLED, then the chiller has an air-cooled condenser. In the cooling mode, the chiller rejects heat via this condenser, the same as an ordinary chiller. In the heating mode, this same heat-exchanger absorbs heat from the air. This chiller is discussed as a separate sub-topic below.</p> <p>If CONDENSER-TYPE = WATER-COOLED, then the chiller has a water-cooled condenser that must be coupled to a LAKE/WELL circulation loop, from which it either absorbs or rejects heat. This chiller is discussed as a separate sub-topic below.</p>
LOOP-TO-LOOP-HP	A chiller which cools a chilled-water circulation-loop, and simultaneously heats a hot-water loop. It is also coupled to a LAKE/WELL circulation-loop that provides the necessary heat balance. This chiller is discussed as a separate sub-topic below.
WATER-ECONOMIZER	Not actually a chiller; this specifies a water-side economizer utilizing a heat-exchanger to cool a CHW loop using a CW loop. This model has many limitations and you should carefully examine the section below which describes this feature (see) and how to use it properly.

Like other chillers, this chiller may have a pump on either the CHW or CW side. The CW flow may be either constant or variable; the higher dT associated with variable improves the tower performance somewhat and gives slightly better results.

CONDENSER-TYPE

Takes a code-word that defines the type of the chiller's condenser.

WATER-COOLED Water-cooled condenser. The chiller's performance curves are defined relative to the entering condenser water temperature (leaving cooling tower temperature). Any type of chiller may be water-cooled. Water-cooled condenser are described in the section *Water-Cooled Condenser*.

AIR-COOLED Air-cooled condenser. The chiller's performance curves are defined relative to the outdoor drybulb temperature. All energy consumption associated with the condenser fans is included in the chiller's ELEC-INPUT-RATIO and associated performance curves; there are no separate keywords describing the condenser fans. Only electric chillers and the heat-pump chiller may be air cooled; all others must be water-cooled.

REMOTE-AIR-COOLED A remotely located, air-cooled condenser. The chiller's performance curves are defined relative to the saturated condensing temperature. Temperature control of the remote condenser, and the energy consumption of its fans, are defined using a separate set of keywords within the CHILLER component. In other words, the chiller's ELEC-INPUT-RATIO and associated performance curves apply to the chiller compressor only.

Only conventional electric chillers may have a remote condenser.
Remote condensers are described in the section *Remote Air-Cooled Condenser*.

REMOTE-EVAP-COOLED A remotely located, evaporatively-cooled condenser. The chiller's performance curves are defined relative to the saturated condensing temperature. Temperature control of the remote condenser, and the energy consumption of its fans, are defined using a separate set of keywords within the CHILLER component. In other words, the chiller's ELEC-INPUT-RATIO and associated performance curves apply to the chiller compressor only.

Only conventional electric chillers may have a remote condenser.
Remote condensers are described in the section *Remote Evaporatively-Cooled Condenser*.

Rated vs. Design Conditions

The program allows chillers to be specified at either the:

Rated conditions – as specified by ARI or other rating organizations. For all chiller types, ARI rates the evaporator conditions as 54°F entering and 44°F leaving chilled water (which corresponds to 2.4 gpm/ton). For water-cooled chillers, the condenser conditions are 85°F entering condenser water at a flow of 3 gpm/ton. Air-cooled chillers are rated at 95°F entering outdoor drybulb temperature. Chillers with remote condensers, are rated at 125°F saturated-condensing temperature.

Design conditions – the actual conditions at which the chiller is sized and designed to operate.

When specifying a chiller, it is important to distinguish whether the stated chiller performance (capacity and energy consumption) are defined at the rated or actual conditions. Most chiller types can be specified at either the ARI rated conditions, or the actual design conditions. However, for centrifugal chillers, it may not make sense to specify performance at the ARI rated conditions, as the chiller *may not be able to actually operate at those conditions*.

For example, consider a water-cooled centrifugal chiller serving a building in a relatively cool, dry climate. The engineer specifies the chiller capacity and efficiency at 46°F leaving chilled water and 76°F entering condenser water. To achieve the specified efficiency at minimum cost, assume the chiller manufacturer configures the the impeller and heat-exchangers to exactly meet the design conditions. If this chiller is then operated at the more extreme ARI conditions of 44°F/85°F, the compressor may not be able to overcome the pressure differential between the evaporator and condenser, and the chiller will surge if it tries to deliver water at 44°F. To operate successfully at 85°F entering condenser water, it will have to deliver water warmer than 44°F.

For this reason, the program defaults assume that centrifugal chillers are specified at the design conditions. All other chiller types are assumed to be specified at the rated conditions, unless you specify otherwise.

The next set of keywords describe the design conditions of a chiller:

DESIGN-CHW-T

The leaving chilled-water temperature at the design conditions. The default is the same as the DESIGN-COOL-T of the chilled-water loop to which this chiller is attached.

DESIGN-COND-T

The condenser temperature at the design conditions. The meaning of this keyword varies according to the condenser type:

Water-cooled – The entering condenser water temperature. The default is the same as the DESIGN-COOL-T of the condenser water loop to which this chiller is attached.

Air-cooled – The entering air temperature. The default is the maximum entering air temperature encountered during cooling.

Remote condenser – The saturated condensing temperature. The default is 125°F for air-cooled, and 105°F for evaporatively cooled.

DESIGN-PLR

For centrifugal chillers only, specifies the ratio of the design capacity to the maximum capacity. The maximum capacity of a centrifugal chiller is often greater than the design capacity; either because of the components used to build up the chiller, or in order to meet the efficiency requirements at the specified conditions.

For example, consider a chiller specified to deliver 500 tons at 44°F chilled water, 80°F entering condenser water at 3 gpm/ton, and 0.6 kW/ton power consumption. The chiller manufacturer's selection program might determine that the least expensive chiller that meets the specifications is actually one having a maximum capacity of 550 tons and a power consumption of 0.64 kW/ton at full load. However, when unload to 500 tons, the efficiency of the chiller improves, and the part load power consumption is 0.6 kW/ton; thereby meeting the engineer's specifications. (Centrifugal chillers are most efficient when running at part load.)

To specify the above chiller in DOE-2, set

SPECIFIED-AT	=	DESIGN-CONDITIONS
CAPACITY	=	6. \$ 500 tons *12000 Btu/ton / 1000000
ELEC-INPUT-RATIO	=	0.171 \$ 0.6 kW/ton * 3413 Btu/kW / 12000 Btu/ton
DESIGN-PLR	=	0.91 \$ 500 design tons / 550 maximum tons

The capacity and power performance curves are always relative to the maximum capacity, not the design capacity. The DESIGN-PLR keyword identifies the design point relative to the maximum operating point on the performance curves.

The next set of keywords describe the rating conditions of a chiller, either ARI or other:

RATED-CHW-T

The chilled-water temperature at the rated conditions, either ARI or other. This is the value at which the chiller performance curves are normalized. Normally, you should not change the default value of this keyword unless you are also specifying the chiller performance curves, and the curves are normalized to a different value.

RATED-COND-T

The condenser temperature at the rated conditions, either ARI or other. The default varies by condenser type. This is the value at which the chiller performance curves are normalized. Normally, you should not change the default value of this keyword unless you are also specifying the chiller performance curves, and the curves are normalized to a different rating condition.

RATED-CW-FLOW

For a water-cooled condenser, specifies the condenser flow at the rated conditions, either ARI or other. This is the value at which the chiller performance curves are normalized. The default for ARI-rated chillers is 3.0 gpm/ton. Normally, you should not change the default value of this keyword unless you are also specifying the chiller performance curves, and the curves are normalized to a different rating condition.

Why is this keyword relevant? Chiller manufacturers normally report performance as a function of the *entering* condenser water temperature, and the DOE-2 performance curves conform to this convention. However, the *leaving* condenser water temperature is actually a more important determinant of chiller performance, and must be taken into account when simulating a chiller with a condenser flow other than the rated flow. The program uses this keyword to bias the entering condenser temperature for off-rated and/or variable condenser flows.

For example, assume a chiller operating at a 3 gpm/ton condenser flow has a 9°F rise through the condenser at rated conditions. In this case, an 85°F entering condenser temperature corresponds to 94°F leaving temperature. If the condenser flow is reduced to 2 gpm/ton, then the rise will be approximately 15°F and the leaving temperature will be 100°F. To account for this increase in leaving temperature, the program will bias the entering temperature by 6°F, so that the value used in the curves for entering condenser temperature is 91°F instead of 85°F. (This example oversimplifies the problem; the program iterates to find the balance point between the biased entering condenser temperature, and the impact of that temperature on capacity, power consumption, rejected heat, and leaving temperature.)

SPECIFIED-AT

accepts a code-word specifying the conditions (capacity and power) at which the user is specifying a chiller.

RATED-CONDITIONS	the default for all non-centrifugal chillers, indicates the user-specified chiller is defined at the ARI or other rated conditions; RATED-CHW-T, RATED-COND-T, etc.
------------------	---

DESIGN-CONDITIONS the default for centrifugal chillers, indicates that the user-specified chiller is defined at the actual design conditions; **DESIGN-CHW-T**, **DESIGN-COND-T**, etc. The program converts the specified design capacity to the corresponding rated capacity. The rated capacity is displayed in all reports.

On an hourly basis, the rated capacity is converted to the actual capacity using the **CAPACITY-FT** performance curve. Similarly, the rated power is converted to the actual power using the **EIR-FT** and **EIR-FPLR**, and/or the **HIR-FT** and **HIR-FPLR** performance curves.

Note that, for an auto-sized chiller, the program always selects the size based on the design conditions, and then translates that size to the rated conditions. However, other parameters, such as the **ELEC-INPUT-RATIO**, may be at either the rated or design conditions.

Chiller Design and Operating Capacity

The next set of keywords describes the chiller's design and operating capacity.

CAPACITY

The cooling capacity of the chiller. The **SPECIFIED-AT** keyword indicates whether the specified capacity is at the **RATED-CONDITIONS** or the **DESIGN-CONDITIONS**.

If you do not specify **CAPACITY**, it defaults to the chilled water loop capacity times **CAPACITY-RATIO**. If no **CAPACITY-RATIO** is input, the capacity will default to the loop capacity divided by the number of chillers attached to the loop.

CAPACITY-RATIO

The fraction of the design loop capacity that the chiller will be sized to meet. This keyword is allowed only if **CAPACITY** is not specified. If you are defining two chillers of identical size that exactly meet the design loop load, set each chiller's **CAPACITY-RATIO** to 0.5. To include a 20% safety factor, set each chiller's **CAPACITY-RATIO** to 0.6. If neither **CAPACITY** nor **CAPACITY-RATIO** is specified, the chiller capacity will default to the loop capacity divided by the number of chillers attached to the loop.

MAX-RATIO

For centrifugal chillers, this keyword has replaced with **DESIGN-PLR**, which has a different meaning than **MAX-RATIO** had. For all other chiller types, the program assumes that the maximum capacity is identical to the rated capacity.

MIN-RATIO

The minimum fraction of rated load at which the chiller can operate continuously. If the load is between zero and **MIN-RATIO** the chiller will cycle on and off. When cycled on, the chiller will run at the **MIN-RATIO**.

CAPACITY-FT

Takes the U-name of a curve that adjusts the capacity of the chiller as a function of the leaving evaporator water temperature and the condenser temperature. This curve should be normalized to 1.0 at the rated conditions (**RATED-CHW-T**, **RATED-COND-T**, etc.).

The meaning of condenser temperature varies according to the type of condenser:

Water-cooled – the entering condenser water temperature (leaving cooling-tower temperature). For condenser flows other than the **RATED-CW-FLOW**, the program will bias the entering condenser temperature to account for the off-rated flow. Refer to the section *Rated vs. Design Conditions* for more information.

Air-cooled – the outdoor air drybulb temperature

Remote condenser – the saturated condensing temperature

HGB-RATIO

The fraction of design capacity below which the chiller uses hot-gas bypass. Used only for electric chillers and engine chillers. To be meaningful, the HGB-RATIO must be greater than the MIN-RATIO; otherwise the chiller will cycle off before initiating the hot-gas bypass. For example, assume the HGB-RATIO=0.4, and the MIN-RATIO=0.25:

If the actual PLR is 0.5, then the chiller is running continuously with no hot-gas bypass.

If the PLR drops to 0.3, then the chiller is running continuously, but below the point at which hot-gas bypass initiates. Power consumption calculated using PLR=0.4 to model the false load due to the hot-gas bypass.

If the PLR drops to 0.15, then the chiller is cycling and hot-gas bypassing simultaneously. The fraction of the hour operating is $\text{Frac} = 0.15/0.25 = 0.6$. When cycled on, the chiller runs at PLR=0.4 to model the hot-gas bypass.

START-UP-TIME

The number of hours of equivalent full-load time required to bring the chiller on-line. For example, if it takes the equivalent of 15 minutes of full load fuel consumption to bring an absorption chiller on-line, then this entry should be 0.25 (hours).

If a chiller is to be used in the current hour, but did not operate the previous hour, then a start-up load is assumed to exist. The equivalent full-load run time added to the current hour's load varies according to how many hours the chiller has been shut down:

1 hour:	50% of this value
2 hours	80% of this value
3 or more hours	100% of this value

SHUT-DOWN-TIME

The number of hours of equivalent full-load time required to shut a chiller down. This value is currently used only for the absorption chillers, and represents the time the solution pump must run during the dilution cycle.

STANDBY-TIME

The number of hours of equivalent full-load time required to maintain a chiller at temperature, when the cooling load is zero. When operating below the MIN-RATIO, the chiller is assumed to be cycling. When cycled on, the chiller will operate at the MIN-RATIO. When off, losses and energy are determined using this keyword. The program interpolates between energy consumed at the MIN-RATIO, and energy in full standby mode; based on the fraction of the time the chiller is cycled on.

Chiller Energy Consumption

The following keywords define the energy consumption of the chiller. Not all keywords are used for every chiller type. For example, an electric chiller does not consume any heat or fuel and so does not have an HIR. However, an absorption chiller may have electrical usage, such as for a spray pump, and the electrical consumption of this pump may vary with load. Consequently, the heat- and fuel-chillers use both the EIR and HIR set of keywords

The program uses the following relationship to calculate the electricity input to the chiller each hour:

$$\begin{aligned} \text{Cap}_{\text{hour}} &= \text{Capacity} * \text{CAPf}(t1,t2) \\ \text{PLR} &= \text{Load} / \text{Cap}_{\text{hour}} \\ dT &= t2 - t1 \\ \text{Elec}_{\text{hour}} &= \text{Cap}_{\text{hour}} * \text{EIR} * \text{EIRf}(t1,t2) * \text{EIRf}(\text{PLR},dT) / 3413 \text{ Btu/kW} \end{aligned}$$

where

Cap _{hour}	hourly capacity, Btuh
Capacity	rated capacity, Btuh
CAPf(t1,t2)	correction to capacity for temperatures, curve CAP-FT
t1	leaving chilled-water temperature, °F
t2	condenser temperature, °F
PLR	Part load ratio
Load	Hourly load, Btuh
dT	Temperature differential across chiller, °F
Elec _{hour}	electric input to the chiller, kW
EIR	rated electric input ratio
EIRf(t1,t2)	correction to EIR for temperatures, curve EIR-FT
EIRf(PLR,dT)	correction to EIR for part-load ratio and dT, curve EIR-FPLR

The meaning of the condenser temperature (t2) varies according to the type of condenser:

Water-cooled – the entering condenser water temperature (leaving cooling-tower temperature). Note that, for condenser flows other than the rated flow, the entering condenser temperature is biased based on leaving temperature to correct the error in the curves that would result otherwise.

Air-cooled – the outdoor air drybulb temperature

Remote condenser – the saturated condensing temperature

If you change any one of the above curves you should either change the others or verify that they are reasonable over the expected range of operating conditions.

Thermal energy consumption of absorption and engine chillers is calculated in a similar manner.

ELEC-INPUT-RATIO

The electric input ratio (EIR) is the ratio of electric input power to capacity (i.e., the inverse of the coefficient of performance (COP)). The EIR is dimensionless, so the same units for input and capacity should be used. The SPECIFIED-AT keyword indicates whether the specified EIR is at the RATED-CONDITIONS or the DESIGN-CONDITIONS.

For absorption chillers (TYPE = ABSOR-1, ABSOR-2 or GAS-ABSOR), ELEC-INPUT-RATIO includes the primary power consumption of the chiller and the electrical power consumption of the solution pumps. For these chillers, the program will override ELEC-INPUT-RATIO if you specify either SOLUTION-PUMP-KW and/or GAS-COMB-FAN-KW. In this case, the program will recalculate the ELEC-INPUT-RATIO as (SOLUTION-PUMP-KW + GAS-COMB-FAN-KW) * 3413 Btu/kW / (CAPACITY*106). Note that GAS-COMB-FAN-KW is the combustion blower power for the gas-fired chiller, and applies only to that chiller type.chiller, and applies only to that chiller type.

EIR-FT

Takes the U-name of a curve that adjusts the electric input ratio as a function of the leaving chilled water temperature and the condenser temperature. This curve should be normalized to 1.0 at the ARI point (RATED-CHW-T, RATED-COND-T, etc.).

The meaning of condenser temperature varies according to the type of condenser:

Water-cooled – the entering condenser water temperature (leaving cooling-tower temperature). For condenser flows other than the RATED-CW-FLOW, the program will bias the entering condenser temperature to account for the off-rated flow. Refer to the section *Rated vs. Design Conditions* for more information on this topic.

Air-cooled – the outdoor air drybulb temperature

Remote condenser – the saturated condensing temperature

EIR-FPLR

Takes the U-name of a curve that adjusts the electric input ratio as a function of

The part load ratio (PLR) – The PLR is defined as the ratio of the hourly load to the hourly capacity;
 $\text{Load} / \text{Cap}_{\text{hour}}$

The evaporator/condenser dT - The temperature differential between the condenser and leaving chilled-water. The meaning of the condenser temperature varies according to condenser type.

For most chillers, the dT has a relatively small effect on part-load performance. However, for variable-speed centrifugal chillers, the effect of dT is as important as the PLR. This is because the pressure rise across the impeller is proportional to the square of the impeller's speed. Unless some form of condenser temperature relief is employed to reduce the temperature (and pressure) differential across the chiller at part load, the performance of a variable-speed chiller may not be significantly different than that of a constant-speed chiller.

To model power consumption as a function of the PLR only, use a CURVE-FIT of TYPE = QUADRATIC or CUBIC. To model as a function of both PLR and dT, use a BI-QUADRATIC-RATIO&DT curve. The curve must be normalized to 1.0 at full load and the rated temperature differential.

Note that, for centrifugal chillers, 'full load' is defined as the 'maximum capacity', not the 'design capacity'. Refer to the DESIGN-PLR keyword for more information.

VARIABLE-SPEED

for the centrifugal chiller types, accepts the value YES or NO indicating whether the chiller utilizes a variable-speed drive. If YES, then the program will select a different default EIR-FPLR performance curve from the library to model part-load performance; this keyword has no other effect.

For the hermetic centrifugal chiller only (ELEC-HERM-CENT), two additional codewords are available to model small frictionless compressors. Selecting either of these will modify the full load ELEC-INPUT-RATIO and the capacity and EIR performance curves:

Sml-Frictionless-Water-3F Specifies a frictionless compressor with a water-cooled condenser. Both the evaporator and condenser are sized for a 3°F (1.67°C) approach. This selection is appropriate for a new chiller. Either a single-compressor or dual-compressor chiller may be modeled by specifying COMPRESSORS/CKT = ONE or TWO; a different default EIR-FPLR curve will be selected accordingly.

Sml-Frictionless-Water-10F Specifies a frictionless compressor with a water-cooled condenser. Both the evaporator and condenser are sized for a 10°F (5.5°C) approach. This selection is appropriate for a retrofit to an existing reciprocating chiller. Either a single-compressor or dual-compressor chiller may be modeled by specifying **COMPRESSORS/CKT = ONE** or **TWO**; a different default EIR-FPLR curve will be selected accordingly.

Part-load capacity reduction in a variable-speed centrifugal chiller utilizes a combination of impeller speed and inlet vanes. To maximize the part-load efficiency of a variable-speed centrifugal chiller, some form on condenser temperature relief must be employed at part load to reduce the temperature (and pressure) differential across the chiller. Otherwise, the performance of a variable-speed chiller may not be significantly different from that of a constant-speed chiller. This is because the pressure rise across the impeller is proportional to the square of the impeller's speed. If the condenser temperature never drops below the design value, then the pressure differential between the evaporator and condenser will remain almost constant, no significant impeller speed reduction will be possible, and most of the capacity reduction will be accomplished via the inlet vanes.

COMPRESSORS/CKT

For a hermetic centrifugal chiller with a small frictionless compressor (**CHILLER:VARIABLE-SPEED = Sml-Frictionless-Water-3F**, or **Sml-Frictionless-Water-10F**), accepts the values **ONE** or **TWO** indicating whether the chiller has a single compressor, or two compressors sharing a common evaporator and condenser. A two-compressor machine has better part-load performance, and can also unload further than a single-compressor chiller.

For electric chillers other than centrifugal, accepts the values **ONE**, **TWO**, **THREE**, and **FOUR** indicating the number of compressors on each circuit. Based on the number of compressors per circuit, the program will select a typical default EIR-FPLR performance curve from the library to model part-load performance; this keyword has no other effect.

The default curves are based on chillers having two independent refrigerant circuits, and up to four compressors per circuit. Not all chiller types have curves for three or four compressors; if you specify more compressors than exist in the performance curves for that chiller type, then the program will select the curve representing the maximum number of compressors for which a curve exists.

More compressors does not always represent better part-load performance; actual performance depends on the chiller configuration, the staging order of compressors, the use of cylinder unloaders or slide valves, the type of expansion valves, etc.

ELEC-TO-COND

Accepts a numeric input that specifies the fraction of the electrical power that is rejected through the condenser. The default varies by chiller type. Generally, for hermetic compression chillers, this entry should be 1.0, as all of the motor power must be rejected through the condenser. For open compression chillers, the default is roughly the same as the motor efficiency, but may be somewhat higher to account for the motor heat that conducts into the chiller via the motor shaft.

HEAT-INPUT-RATIO

The ratio of fuel heat input to chiller cooling capacity at full load (i.e, at the rated conditions). Used only for fuel-consuming chillers. Note that this is a dimensionless ratio, so you must convert heat input and cooling capacity to the same units before dividing.

HIR-FT

Takes the U-name of a curve that gives the chiller HIR as a function of the exiting chilled water temperature and the entering condenser water temperature. This curve should be normalized to 1.0 at the ARI rating point.

The meaning of condenser temperature varies according to the type of condenser:

Water-cooled – the entering condenser water temperature (leaving cooling-tower temperature). For condenser flows other than the RATED-CW-FLOW, the program will bias the entering condenser temperature to account for the off-rated flow. Refer to the section *Rated vs. Design Conditions* for more information on this topic.

Air-cooled – the outdoor air drybulb temperature

Remote condenser – the saturated condensing temperature

HIR-FPLR

Takes the U-name of a curve that gives the chiller HIR as a function of:

The part load ratio (PLR) – The PLR is defined as the ratio of the hourly load to the hourly capacity;
 $\text{Load} / \text{Cap}_{\text{hour}}$

The temperature differential between the condenser and leaving chilled-water (dT) – The meaning of the condenser temperature varies according to condenser type.

For most chillers, the dT has a relatively small effect on part-load performance. However, for variable-speed centrifugal chillers, the effect of dT is as important as the PLR. This is because the pressure rise across the impeller is proportional to the square of the impeller's speed. To maximize the efficiency at part load, some form of condenser temperature relief must be employed to reduce the temperature (and pressure) differential across the chiller at part load.

To model power consumption as a function of the PLR only, use a CURVE-FIT of TYPE = QUADRATIC or CUBIC. To model as a function of both PLR and dT, use a BI-QUADRATIC-RATIO&DT curve. The curve must be normalized to 1.0 at full load and the rated temperature differential.

HEAT-TO-COND

The fraction of the thermal or fuel energy that is rejected to the condenser. This value should normally be 1.0 for all hot-water or steam absorption chillers. For gas-fired chillers, this value should be the same as the burner efficiency. For engine chillers, this value should be the same as the engine efficiency, but may be somewhat higher to account for additional engine heat that conducts into the chiller compressor via the shaft.

AUX-KW

Auxiliary electrical consumption, such as for a control panel or crankcase heater.

AUX-MODE

Accepts a code-word specifying when the AUX-KW is consumed.

ALWAYS	Auxiliary power is consumed all hours.
WHEN-ON	Auxiliary power is consumed only during the hours the chiller is operating.
WHEN-OFF	Auxiliary power is consumed only during the hours the chiller is off.
SCHEDULED	The power consumption is scheduled (see AUX-SCH).

AUX-SCHEDULE

When AUX-MODE = SCHEDULED, takes the U-name of a schedule of TYPE = MULTIPLIER that varies the AUX-KW on an hourly basis.

AUX-METER

Takes the U-name of the AUX-METER to which the auxiliary electricity consumption of the chiller is assigned.

ELEC-METER

Takes the U-name of the ELEC-METER to which the electricity consumption of the chiller is assigned. The default is the MASTER-METER: COOL-ELEC-METER.

FUEL-METER

Takes the U-name of the FUEL-METER to which the fuel consumption of the chiller is assigned. The default is the MASTER-METER: COOL-FUEL-METER.

Attachment to Chilled-Water Loop

The following keywords describe how the chiller is attached to a chilled-water loop. If the chiller evaporator has a dedicated pump in a equipment loop, the pump is attached to the chiller from within the chiller command.

CHW-LOOP

Takes the U-name of the primary CHW loop to which this chiller is attached.

CHW-PUMP

Takes the U-name of a PUMP directly attached to the chiller's evaporator. Usually, this pump will be a equipment-recirculation pump and will act to decouple the flow of the chiller from the loop. In this case, the pump may have CHW-FLOW-CTRL = CONSTANT-FLOW or VARIABLE-FLOW, and will remove the chiller evaporator head requirement from the primary loop. If the loop does not have its own pumps, then this pump will also power the loop. In this case, the head of this pump will be the sum of the maximum coil head, the loop distribution head (including static head), and the chiller's evaporator head. The hourly flow of the pump (and chiller) will be determined based on the loop flow and the number of other chillers running (CHW-FLOW-CTRL does not apply in this case).

CHW-DT

The design temperature change of the chilled water through the chiller. The default is the LOOP-DESIGN-DT of the chilled-water loop. The program uses this keyword to determine the chiller's design flow, which in turn is used to size the equipment-recirculation pump, if any, on the evaporator, and calculate the hourly pressure drop. If no equipment-recirculation pump exists, then the flow through the chiller is based on the LOOP-DESIGN-DT.

CHW-HEAD

The head loss through the chiller at design flow.

CHW-STATIC-HEAD

The static head of the chiller (non-varying with flow). Normally, this value should be allowed to default to zero.

CHW-FLOW-CTRL

Takes a code-word that specifies the type of flow through the chiller's evaporator. While many manufacturers recommend that the flow through the evaporator be constant, others have incorporated controls that allow the chiller to operate safely with variable flow. This keyword applies only when the CHW-PUMP is acting as a equipment-recirculation pump. If the CHW-PUMP is also powering the loop, or the chiller does not have a pump, then this keyword is ignored.

CONSTANT-FLOW Indicates that the evaporator flow is independent of the chiller load. Note that unless a CHW-PUMP exists the flow through the chiller evaporator will depend on the primary loop flow. For example, if the flow in the primary loop is variable, then the flow through the chiller will also be variable.

VARIABLE-FLOW The evaporator flow varies linearly with the chiller load.

CHW-MIN-FLOW

When CHW-FLOW-CTRL = VARIABLE-FLOW, specifies the minimum allowable fraction of the design flow through the evaporator. Typically, the minimum flow should be above the point where the flow transitions from turbulent to laminar.

CHW-MAX-FLOW

The ratio of the maximum allowable flow ratio to the design flow ratio. This keyword is used as a check when allocating loads to the chillers, and is best illustrated using an example. Assume that a chilled-water loop is constant flow (3-way valves on all coils) and has two chillers attached, each sized to meet 50% of the design load. In the current hour under consideration, the cooling load is 40% of design. Based on load, one chiller is all that is needed. However, since the loop is constant flow, one chiller operating would have to handle twice its design flow (at approximately four times its design head). A flow rate this high would probably result in severe tube erosion in the evaporator, and could void the manufacturer's warranty. In addition, the excessively high pressure drop through the evaporator would probably not allow the pump to meet the required flowrate. Each hour, the program first allocates the load to the equipment (by default or through the COOL-EQUIP-CTRL defined by you). It then checks to see if the flow through each equipment component does not exceed the CHW-MAX-FLOW. If the flow exceeds this limit, then the program reallocates the load to as many equipment units as required to meet the flow requirements.

In the above example, a 40% loop load would be met by both chillers running, each operating at 20% capacity. To prevent the program from reallocating the load based on flow, set the CHW-MAX-FLOW to a higher value. (A value of 2.0 or higher in the above example would suffice). The pump head should also be manually set, as the program does not anticipate equipment operating head higher than design.

Attachment to Hot-Water Loop

For absorption chillers, the next set of keywords describe how this chiller is attached to a hot-water or steam loop. If the chiller has a dedicated hot-water pump in a equipment loop, the pump is attached to the chiller using the PUMP command.

HW-LOOP

Takes the U-name of the HW loop to which this chiller is attached. This is a mandatory entry for hot-water/steam-fired absorption chillers, and optional for a gas-fired chiller/heater. Note that a hot water absorption chiller is a demander on the HW-LOOP (similar to a heating coil), whereas a chiller/heater is a supplier to the HW-LOOP (similar to a boiler). As such, a chiller/heater can attach to the same loop types as a boiler.

HW-PUMP

Similar to CHW-PUMP. For a hot-water absorption chiller, this pump will overcome the head of the chiller's generator only; it cannot be used to power the hot water loop. If not specified, the head of the generator will be passed onto the loop. For a chiller/heater, the chiller is a supplier to the heating loop and is functionally identical to a boiler. A pump attached through this keyword may act either as a equipment-recirculation pump (assuming the loop has its own pumps), or may power the loop (if the loop does not have its own pumps).

HW-DT

The design temperature change of the hot water through the absorption chiller. The program uses this keyword to determine the component's design flow, which in turn is used to size the equipment-recirculation pump, if any, on

the component, and to calculate the hourly pressure drop.. Defaults to the LOOP-DESIGN-DT of the hot water loop.

HW-HEAD

The hot water pressure drop through the absorption chiller at the design flow rate due to friction (i.e., not including any static head).

HW-STATIC-HEAD

The hot water pressure drop through the absorption chiller that is independent of flow. (Use HW-HEAD to specify the head loss due to friction.)

HW-FLOW-CTRL

Takes a code-word that specifies the type of hot water flow through the absorption chiller. While many manufacturers recommend that the flow through the evaporator be constant, others have incorporated controls that allow the chiller to operate safely with variable flow.

CONSTANT-FLOW The hot water flow is independent of the chiller load.

VARIABLE-FLOW The hot water flow varies linearly with the load.

HW-MIN-FLOW

When HW-FLOW-CTRL = VARIABLE-FLOW, specifies the minimum allowable fraction of the design flow through the chiller. Typically, the minimum flow should be above the point where the flow transitions from turbulent to laminar flow.

HW-MAX-FLOW

The ratio of the maximum allowable flow ratio to the design flow ratio. Similar to CHW-MAX-FLOW, but applies only to chiller/heaters where the chiller acts in a capacity identical to a boiler on the hot water loop. The program will check to see that the maximum flow through each piece of equipment is not exceeded, and if it is, will turn on more equipment as required to meet the loop flow.

Water-Cooled Condenser

The following set of keywords describes how the chiller is attached to a condenser water loop. If the chiller has a dedicated condenser-water pump in a equipment loop, the pump is attached to the chiller from within the PUMP command. These keywords apply only to water-cooled condensers (CONDENSER-TYPE = WATER-COOLED).

CW-LOOP

When CONDENSER-TYPE = WATER-COOLED, takes the U-name of the CW loop to which this chiller is attached.

CW-PUMP

Takes the U-name of a PUMP directly attached to the chiller's condenser. This pump may be either a equipment-recirculation pump, or may power the loop. If you have more than one chiller attached to a given CW loop, and the loop does not have a pump, then each chiller must have a condenser pump.

CW-DT

The design temperature change of the water flowing through the condenser. The program uses this keyword to determine the component's design flow, which in turn is used to size the equipment-recirculation pump, if any, on the component, and to calculate the hourly pressure drop. Default is the LOOP-DESIGN-DT of the condenser loop.

Note that the CW-DT will usually result in a calculated design flow somewhat different than the rated flow, RATED-CW-FLOW. Chiller manufacturers normally report performance as a function of the *entering* condenser water temperature, and the DOE-2 performance curves conform to this convention. However, the *leaving* condenser water temperature is actually a more important determinant of chiller performance, and must be taken into account when simulating a chiller with a condenser flow other than the rated flow. The program corrects for off-rated condenser flows, either fixed or variable, by biasing the entering condenser water temperature. Please refer to the section *Rated vs. Design Conditions* for more information on this topic.

CW-HEAD

The pressure drop through the condenser at the design flow rate.

CW-STATIC-HEAD

The static head of the condenser (non-varying with flow).

CW-FLOW-CTRL

Takes a code-word that specifies the type of flow through the chiller.

CONSTANT-FLOW	Indicates that the condenser flow is independent of the chiller load.
VARIABLE-FLOW	The condenser flow varies linearly with the load, in accordance with CW-MIN-FLOW and CW-MIN-PLR. If the leaving condenser temperature exceeds the MAX-COND-T, then flow will be increased, up to the design flow, to maintain setpoint.
	$\text{PLRratio} = (\text{PLR} - \text{CW-MIN-PLR}) / (1.0 - \text{CW-MIN-PLR})$ $\text{FlowRatio} = \text{CW-MIN-FLOW} + (1. - \text{CW-MIN-FLOW}) * \text{PLRratio}$
	To prevent the water flow from falling off as rapidly as the load, make the CW-MIN-PLR smaller than the CW-MIN-FLOW.

CW-MIN-FLOW

When CW-FLOW-CTRL = VARIABLE-FLOW, specifies the minimum allowable fraction of the design flow through the evaporator. This flow is assumed to occur at the part-load ratio corresponding to the CW-MIN-PLR, and is linear between full load and this part load. Typically, the minimum flow should be above the point where the flow transitions from turbulent to laminar.

Note that the flow will be increased, up to design, if the leaving condenser temperature exceeds the MAX-COND-T.

CW-MIN-PLR

When CW-FLOW-CTRL = VARIABLE-FLOW, specifies the minimum part load ratio at which the minimum flow occurs. The default is the same as the CW-MIN-FLOW, so that condenser flow is exactly proportional to load.

Note that the flow will be increased, up to design, if the leaving condenser temperature exceeds the MAX-COND-T.

MAX-COND-T

When CW-FLOW-CTRL = VARIABLE-FLOW, specifies the temperature that acts as an upper limit on the leaving condenser temperature. Normally, the flow will be reset linearly according to the chiller's part-load ratio (PLR), the CW-MIN-FLOW and the CW-MIN-PLR. However, if the leaving condenser temperature exceeds the MAX-COND-T, then the flow will be controlled, up to design, to maintain the MAX-COND-T.

MIN-COND-T

Specifies the minimum allowable condensing temperature setpoint. This value will override any of the control schemes to maintain the setpoint at or above this value. Some chillers may require a certain pressure differential between the evaporator and the condenser in order to maintain full refrigerant flow through an expansion valve. If the condenser pressure drops too low, then chiller capacity will be adversely affected.

For water-cooled condensers, this value represents the minimum entering condenser water temperature.

For air-cooled chillers, this value represents the minimum entering air temperature

For remote condensers, this value is the minimum allowable saturated condensing temperature.

Remote Air-Cooled Condenser

A remote condenser is a sub-component of a CHILLER. Its keywords are contained within the CHILLER component, but it has its own temperature control sequences, and the power consumption of its fans are calculated separately from the chiller's ELEC-INPUT-RATIO and associated performance curves.

Since a remote condenser is essentially separate from its chiller, the chiller's performance curves must be defined in terms of the saturated condensing temperature of the condenser. The outdoor drybulb has no direct impact on the chiller, as the condenser has its own temperature control strategy. Note however, that the condenser temperature will float up if overloaded, and this will affect the chiller performance.

COND-CAPACITY

Specifies the capacity of the condenser at a given temperature differential between saturated condensing temperature and ambient drybulb temperature, SCT-AMB-DT. If you do not specify the capacity, it will default to the design heat rejection load of the chiller. The program will not allow you to specify the condenser's capacity unless you also specify the chiller's capacity.

SCT-AMB-DT

Specifies the differential between the saturated condensing temperature and the outdoor drybulb temperature at which the COND-CAPACITY is specified.

When COND-CAPACITY is specified, this keyword is required

When COND-CAPACITY is not specified, you may define this keyword. If you do not, the program will default it to be the difference between the DESIGN-COND-T and the maximum outdoor drybulb temperature encountered during cooling.

COND-SETPT-CTRL

Accepts a code-word specifying the saturated condensing temperature setpoint control:

FIXED	the default, specifies that the temperature setpoint is constant all hours.
VARIABLE	specifies that the condensing temperature setpoint varies according to the hourly drybulb temperature, plus a fixed differential; the differential being specified by COND-SETPT-DT.
AMBIENT	specifies that the condenser fans are staged according to the hourly drybulb temperature. The fraction of the condenser that is active is defined by the curve

AMB-FRAC-FT. The actual condensing temperature then floats according to the load, the outdoor temperature, and the fraction of the condenser that is active.

COND-SETPT-T

When COND-SETPT-CTRL is FIXED, specifies the saturated condensing temperature (SCT) setpoint. The condenser will hold this setpoint all hours, unless the load or outdoor temperature is such that the SCT must float upward. In this case, the program will iterate to find the balance point between the SCT and the chiller performance.

COND-SETPT-DT

When COND-SETPT-CTRL is VARIABLE, specifies the saturated condensing temperature setpoint differential.

For example, if a chiller has an air-cooled condenser, this keyword is 20°F, and the drybulb temperature is 84°F, then the current condensing temperature setpoint is 104°F.

MIN-COND-T

Specifies the minimum allowable condensing temperature setpoint. This value will override any of the control schemes to maintain the setpoint at or above this value. Some chillers may require a certain pressure differential between the evaporator and the condenser in order to maintain full refrigerant flow through an expansion valve. If the condenser pressure drops too low, then chiller capacity will be adversely affected.

For water-cooled condensers, this value represents the minimum entering condenser water temperature.

For air-cooled chillers, this value represents the minimum entering air temperature

For remote condensers, this value is the minimum allowable saturated condensing temperature.

COND-FAN-CTRL

When COND-SETPT-CTRL is FIXED or VARIABLE, accepts a code word specifying the mechanism by which the fans are controlled to hold the setpoint. The value of this code word is used to select a curve from the library that modifies the fan power consumption as a function of the condenser load (COND-PWR-FPLR).

PRESSURE-SWITCHES the default, specifies that the fans are staged/cycled according to the condensing pressure (temperature). Power consumption is assumed to be linear with load. The default curve is Rcond-Fan-Pwr-fPLR-ACpress.

DAMPER-MODULATION specifies that fans run continuously, with air flow modulated by discharge dampers. The default curve is Rcond-Fan-Pwr-fPLR-Damper.

TWO-SPEED-FANS specifies a condenser having two-speed fans. The default curve is Rcond-Fan-Pwr-fPLR-2speed.

VFD-ON-FANS specifies a condenser with a variable-speed drive. The default curve is Rcond-Fan-Pwr-fPLR-VFDair or Rcond-Fan-Pwr-fPLR-VFDevap.

AMB-FRAC-FT

when COND-SETPT-CTRL is AMBIENT, accepts the U-name of a curve that defines the fraction of the condenser that is active as a function of the outdoor drybulb or wetbulb temperature. This curve approximates the effect of staging or modulating fans directly as a function of ambient temperature, without regard to the actual condensing temperature.

COND-FAN-EIR-TD

is the electric input to nominal capacity ratio for the component fan expressed as

$$\text{FanEIR} = (\text{Fan electric power in Btuh}) / (\text{Condenser capacity in Btuh/TD})$$

where TD is the SCT-AMBIENT-TD.

The default for air-cooled condensers is 0.55 Btu-TD/Btu, which corresponds to approximately 0.28 HP per 15,000 Btuh at 10°F TD.

COND-PWR-FPLR

accepts the U-name of a curve that modifies the condenser fan energy consumption as a function of the condenser part load ratio.

Remote Evaporatively-Cooled Condenser

An evaporatively-cooled remote condenser consists of a refrigerant-to-water heat-exchanger, a fan to circulate air the heat-exchanger, and a pump that sprays water to evaporatively cool the air and refrigerant. A remote condenser is a sub-component of a CHILLER. Its keywords are contained within the CHILLER component, but it has its own temperature control sequences, and the power consumption of its fans are calculated separately from the chiller's ELEC-INPUT-RATIO and associated performance curves.

Since a remote condenser is essentially separate from its chiller, the chiller's performance curves must be defined in terms of the saturated condensing temperature of the condenser. The outdoor wetbulb has no direct impact on the chiller, as the condenser has its own temperature control strategy. Note however, that the condenser temperature will float up if overloaded, and this will affect the chiller performance.

Capacity

This following set of keywords describe how the condenser capacity is defined.

DESIGN-WETBULB

Specifies the design wetbulb temperature of the condenser.

COND-CAPACITY

Specifies the capacity of the condenser at either the rated conditions or the design conditions. If you do not specify the capacity, it will default to the design heat rejection load of the chiller. The program will not allow you to specify the condenser's capacity unless you also specify the chiller's capacity.

The SPECIFIED-AT keyword determines whether the user-specified capacity is at the rated conditions or the design conditions:

The rated conditions (to which the COND-CAP-FT curve is normalized) are 105°F saturated condensing temperature and 78°F outdoor wetbulb temperature (40.5°C/25.5°C).

The design conditions are the DESIGN-COND-T and the DESIGN-WETBULB. If you specify the capacity at the design conditions, the program will translate the capacity to the rated conditions. The rated capacity will be modified hourly according to the actual conditions.

COND-CAP-FT

Accepts the U-name of a curve that modifies the design condenser capacity as a function of the saturated condensing temperature and the wetbulb temperature. This curve should be normalized to the rating conditions.

The default curve assumes rating conditions of 105°F saturated condensing temperature and 78°F outdoor wetbulb temperature (40.5°C/25.5°C).

Power Consumption

The following set of keywords define the condenser power consumption, and how that power varies hourly.

COND-FAN-EIR

specifies the electric input ratio (EIR) of the condenser fan(s), where the EIR is a dimensionless ratio of the fan energy consumption to the condenser capacity:

$$\text{EIRfan} = \text{Fan power, Btu} / \text{Condenser capacity, Btu}$$

You may specify the fan EIR at either the rated or design condenser capacity, according to the SPECIFIED-AT keyword. If you specify the EIR at the design capacity, the program will translate it to the rated capacity.

The hourly fan energy is calculated as:

$$\text{kWfan} = \text{RatedCap} * \text{EIRfan} * f(\text{PLR}) * \text{Frac}$$

where RatedCap is the rated capacity of the chiller, f(PLR) is a curve that modifies fan energy as a function of the condenser part load ratio (COND-PWR-FPLR), and Frac is the fraction of the hour the chiller is operating.

COND-PUMP-EIR

specifies the electric input ratio (EIR) of the condenser spray pump(s), where the EIR is a dimensionless ratio of the pump energy consumption to the condenser capacity:

$$\text{EIRpump} = \text{Pump power, Btu} / \text{Condenser capacity, Btu}$$

You may specify the pump EIR at either the rated or design condenser capacity, according to the SPECIFIED-AT keyword. If you specify the EIR at the design capacity, the program will translate it to the rated capacity.

The condenser pump energy is independent of condenser load, but will cycle on/off if the chiller is also cycling.

COND-PWR-FPLR

accepts the U-name of a curve that modifies the condenser fan energy consumption as a function of the condenser part load ratio.

Temperature Control

The next set of keywords describes how the saturated condensing temperature is controlled.

COND-SETPT-CTRL

Accepts a code-word specifying the saturated condensing temperature setpoint control:

FIXED	the default, specifies that the temperature setpoint is constant all hours.
VARIABLE	specifies that the condensing temperature setpoint varies according to the hourly wetbulb temperature, plus a fixed differential; the differential being specified by COND-SETPT-DT.
AMBIENT	specifies that the condenser fans are staged according to the hourly wetbulb temperature. The fraction of the condenser that is active is defined by the curve

AMB-FRAC-FT. The actual condensing temperature then floats according to the load, the outdoor temperature, and the fraction of the condenser that is active.

COND-SETPT-T

When COND-SETPT-CTRL is FIXED, specifies the saturated condensing temperature (SCT) setpoint. The condenser will hold this setpoint all hours, unless the load or outdoor temperature is such that the SCT must float upward. In this case, the program will iterate to find the balance point between the SCT and the chiller performance.

COND-SETPT-DT

When COND-SETPT-CTRL is VARIABLE, specifies the saturated condensing temperature setpoint differential.

For example, if a chiller has an evaporatively-cooled condenser, this keyword is 10°F, and the wetbulb temperature is 74°F, then the current condensing temperature setpoint is 84°F.

MIN-COND-T

Specifies the minimum allowable condensing temperature setpoint. This value will override any of the control schemes to maintain the setpoint at or above this value. Some chillers may require a certain pressure differential between the evaporator and the condenser in order to maintain full refrigerant flow through an expansion valve. If the condenser pressure drops too low, then chiller capacity will be adversely affected.

For water-cooled condensers, this value represents the minimum entering condenser water temperature.

For air-cooled chillers, this value represents the minimum entering air temperature

For remote condensers, this value is the minimum allowable saturated condensing temperature.

COND-FAN-CTRL

When COND-SETPT-CTRL is FIXED or VARIABLE, accepts a code word specifying the mechanism by which the fans are controlled to hold the setpoint. The value of this code word is used to select a curve from the library that modifies the fan power consumption as a function of the condenser load (COND-PWR-FPLR).

PRESSURE-SWITCHES the default, specifies that the fans are staged/cycled according to the condensing pressure (temperature). Power consumption is assumed to be linear with load. The default curve is Rcond-Fan-Pwr-fPLR-ACpress.

DAMPER-MODULATION specifies that fans run continuously, with air flow modulated by discharge dampers. The default curve is Rcond-Fan-Pwr-fPLR-Damper.

TWO-SPEED-FANS specifies a condenser having two-speed fans. The default curve is Rcond-Fan-Pwr-fPLR-2speed.

VFD-ON-FANS specifies a condenser with a variable-speed drive. The default curve is Rcond-Fan-Pwr-fPLR-VFDair or Rcond-Fan-Pwr-fPLR-VFDevap.

AMB-FRAC-FT

when COND-SETPT-CTRL is AMBIENT, accepts the U-name of a curve that defines the fraction of the condenser that is active as a function of the outdoor drybulb or wetbulb temperature. This curve approximates the effect of staging or modulating fans directly as a function of ambient temperature, without regard to the actual condensing temperature.

Heat Recovery to Hot-Water Loop

The following keywords define heat recovery available from the chiller. Any chiller is capable of heat recovery in a temperature range similar to its design condensing temperature. For higher temperature heat recovery, a chiller of type ELEC-HTREC should be defined.

For heat recovery, it is assumed that the chiller has a second condenser that attaches to a loop (often called a double-bundle condenser). When heat recovery is active, the condenser loop temperature controls are overridden so that heat is rejected at the HTREC temperature setpoint. Any heat not taken by the heat-reclaim loop will be rejected to the condenser-water loop.

MAX-HTREC

The fraction of design condenser heat that is available for heat recovery. The default is 0.0 for all chillers except the ELEC-HTREC, whose default is 0.95. The amount of heat reclaimed on an hourly basis will not exceed this value. For the engine chiller, this keyword does not apply as no condenser heat is assumed recoverable. Instead, heat from the engine jacket and exhaust is recovered.

HTREC-LOOP

When MAX-HTREC is non-zero, takes the U-name of a HW, WLHP, or DHW loop to which this chiller will attempt to provide recovered heat.

MAX-RECOVER-T

The maximum temperature at which heat can be recovered. The default is 105F (40.5C) for the ELEC-HTREC, 200F (93.3C) for the engine chiller, and 95F (35C) for all other chiller types. Heat will be recovered whenever the HTREC-LOOP's return temperature is less than this value. The amount recovered will depend on the loop flow, the return temperature, and the lesser of the loop's supply temperature or the MAX-RECOVER-T. Note that the HTREC-LOOP's supply temperature setpoint must be compatible with the MAX-RECOVER-T for heat to be recovered. For example, the default supply setpoint for the DEFAULT-HW loop is 180F (82.2C) and it is highly unlikely that the return temperature will ever be less than the MAX-RECOVER-T for a chiller. As a result, no heat will be recovered unless the supply temperature is reduced to the 90-120F (32.2-48.9C) range.

HTREC-PUMP

Takes the U-name of a PUMP that acts on the HTREC-HEAD and HTREC-STATIC-HEAD of this chiller. If not specified, the head will be passed on to the loop.

HTREC-DT

The design temperature change of the water through the heat recovery heat-exchanger. The default is the LOOP-DESIGN-DT of the attached loop.

HTREC-HEAD

The head of the heat recovery heat-exchanger. Note that all heat recovery devices are in parallel with each other, and the head on the loop attributable to heat recovery devices is the maximum head of any of the heat recovery devices. If all of the heat recovery devices have their own HTREC-PUMPs, then the heat recovery head on the loop is zero. Otherwise, the design head on the loop is equal to the maximum coil head, plus the piping head, plus the maximum equipment head (boilers, etc.), plus the maximum heat recovery head. In other words, the heat recovery devices are in parallel with each other, but are in series with the boilers or other heating devices.

HTREC-STATIC-HEAD

The static head of the chiller's heat-recovery heat-exchanger (non-varying with flow).

HTREC-FLOW-CTRL

Takes a code-word that specifies the type of flow through the chiller.

CONSTANT-FLOW The heat recovery flow is independent of the chiller load. Note that unless a HTREC-PUMP exists, the flow through the exchanger will be dependent on the primary loop flow. For example, if the flow in the primary loop is variable, then the flow through the heat-exchanger will also be variable.

VARIABLE-FLOW The heat recovery flow varies linearly with the chiller load.

HTREC-MIN-FLOW

When HTREC-FLOW-CTRL = VARIABLE-FLOW, specifies the minimum allowable fraction of the design flow through the heat recovery heat-exchanger. Typically, the minimum flow should be above the point where the flow transitions from turbulent to laminar flow.

Heat-recovery chiller (ELEC-HTREC)

The following keywords are specific to this chiller type.

HGB-RATIO-HTREC

The hot gas bypass ratio when in the heat recovery mode. When the chiller is not in the heat recovery mode, the condensing temperature is assumed to be lower, and the chiller uses the normal HGB-RATIO instead of the HGB-RATIO-HTREC.

Absorption Chillers (ABSOR-1, ABSOR-2, and GAS-ABSOR)

SOLUTION-PUMP-KW

The electric consumption of the solution pump. The default assumes that the solution pump kW is included in the ELEC-INPUT-RATIO. The program overrides the ELEC-INPUT-RATIO if you specify the SOLUTION-PUMP-KW. In this case, the program will recalculate the ELEC-INPUT-RATIO as $\text{SOLUTION-PUMP-KW} * 3413 \text{ Btu/kW} / (\text{CAPACITY} * 106)$.

For a gas-fired chiller, the program also includes the GAS-COMB-FAN-KW in the recalculated ELEC-INPUT-RATIO

Gas-Fired Absorption Chiller (GAS-ABSOR)

HEAT/COOL-CAP

The ratio of the design heating capacity to the design cooling capacity.

GAS-HCAP-FPLRC

Takes the U-name of a curve that modifies the heating capacity as a function of the cooling part load ratio. As the cooling load increases, less of the burner capacity will be available for heating.

GAS-HW-XEFF

The burner efficiency during heating. The burner efficiency for heating is assumed constant for all combinations of heating/cooling loads.

GAS-DESC-XEFF

The burner efficiency when regenerating a desiccant system. The burner efficiency for desiccant regeneration is assumed constant for all combinations of heating/cooling loads. Note that desiccant systems are attached to a GAS-ABSOR chiller using the SYSTEM:DESC-CHILLER keyword.

GAS-COMB-FAN-KW

The electric consumption of the combustion blower. The default assumes that the blower kW is included in the ELEC-INPUT-RATIO. The program overrides the ELEC-INPUT-RATIO if you specify either the GAS-COMB-FAN-KW and/or the SOLUTION-PUMP-KW. In this case, the program will recalculate the ELEC-INPUT-RATIO as $(\text{SOLUTION-PUMP-KW} + \text{GAS-COMB-FAN-KW}) * 3413 \text{ Btu/kW} / (\text{CAPACITY} * 106)$.

GAS-HIR-FDESCT

Takes the U-name of a curve defining the HEAT-INPUT-RATIO as a function of the desiccant regeneration temperature. When regenerating a desiccant system, the ARI condensing temperature (85F or 29.4C) is substituted in the HIR-FT curve to cancel out the effect of the condensing temperature, and the regeneration temperature (calculated hourly in the desiccant algorithms) is used in this curve to modify the chiller's fuel consumption.

GAS-QREG-FDESCT

Takes the U-name of a curve defining the available regeneration energy as a function of the required regeneration temperature.

Engine-Driven Chiller (ENGNE)**ENG-HEAT-TO-JAC**

The fraction of design fuel consumption that is recoverable from the jacket of an engine-chiller. For energy to be conserved, the sum of the HEAT-TO-COND, ENG-HEAT-TO-JAC, and ENG-HEAT-TO-EXH should be less than 1.0.

ENG-HEAT-TO-EXH

The fraction of design fuel consumption that is recoverable from the exhaust of an engine-chiller. Note that this fraction represents the amount of exhaust heat that is recoverable, not the total exhaust heat. For energy to be conserved, the sum of the HEAT-TO-COND, ENG-HEAT-TO-JAC, and ENG-HEAT-TO-EXH should be less than 1.0, as not all of the exhaust heat will be recoverable.

ENG-HTREJ-FT

Takes the U-name of a curve that modifies the amount of recoverable heat as a function of the entering condenser temperature.

ENG-HTREJ-FPLR

Takes the U-name of a curve that modifies the amount of recoverable heat as a function of the cooling part load ratio.

Air-to-Water Heat-Pump (HEAT-PUMP, AIR-COOLED)

An air-to-water heat pump serving a 2-pipe fan coil system is simulated using a chiller of TYPE = HEAT-PUMP and CONDENSER-TYPE = AIR-COOLED. When the 2-pipe circulation-loop is in the cooling mode, the unit acts identically to an air-cooled electric chiller. When the loop is in the heating mode, a changeover valve causes chiller to act as a heat pump, heating the loop by absorbing heat from the air. In the heating mode, the chiller can deliver water as hot as 130°F. Note, however, that the maximum temperature varies with outdoor temperature.

In the cooling mode, the unit acts identically to an air-cooled electric chiller, and all keywords applicable to an electric chiller apply to this chiller type, with the following exceptions:

Condenser type – The CONDENSER-TYPE should be specified as AIR-COOLED. You may also specify WATER-COOLED, which is covered in a separate section. No other condenser types are acceptable.

Heat recovery – This chiller is offered as a packaged self-contained unit, and heat recovery in the cooling mode is not available.

In the heating mode, the unit acts as a heat pump, and its performance is may be significantly different than in the cooling mode. The following keywords define the unit's performance when heating: Note that, for the sake of consistency with other chillers, references to "condenser" in the following keywords refer to the heat-exchanger that rejects heat when in the cooling mode. In the heating mode, this heat-exchanger is actually the evaporator, however the keywords refer to it as a condenser.

Since this type of chiller is common in Europe, but not in the United States, the performance curves are normalized at the Eurovent rating conditions, rather than ARI.

DESIGN-HW-T

The leaving hot-water temperature at the heating design conditions. The default is the same as the DESIGN-HEAT-T of the 2-pipe loop to which this chiller is attached.

DESIGN-COND-T-HT

The air-side heat-exchanger entering air temperature at the design heating conditions. The default is the minimum outdoor temperature encountered during heating when the building is occupied.

RATED-HW-T

specifies the leaving hot-water temperature at the rated conditions, either ARI or Eurovent (The default is for Eurovent). This is the value at which the heating mode performance curves are normalized. Normally, you should not change the default value of this keyword unless you are also specifying the heat-pump performance curves, and the curves are normalized to a different value.

RATED-COND-T-HT

The air-side heat-exchanger entering air temperature when in the heating mode, at the rated conditions. This is the value at which the heating mode performance curves are normalized. Normally, you should not change the default value of this keyword unless you are also specifying the heat-pump performance curves, and the curves are normalized to a different value.

HEAT/COOL-CAP

Is the ratio of the heating capacity to the cooling capacity at the standard rating conditions.

The chiller's CAPACITY is the cooling capacity at the standard cooling rating conditions (SPECIFIED-AT = RATED-CONDITIONS). At the standard heating rating conditions, the heating capacity is usually very close to the cooling CAPACITY. If, however, the heating capacity was only 80% of the cooling capacity, then this keyword would have a value of 0.8

When the CAPACITY is allowed to default:

Cooling capacity - The program looks at the peak cooling requirement at the actual peak conditions, calculates the capacity at these conditions, and translates the capacity to the rated conditions.

Heating capacity – The program looks at the peak heating requirements at the actual peak heating conditions, calculates the heating capacity at these conditions, and translates the capacity to the rated conditions.

Greater of the two – The program takes the rated heating capacity and calculates an equivalent cooling capacity by dividing by the HEAT/COOL-CAP. The CAPACITY is the greater of the rated cooling capacity, or the equivalent cooling capacity required for heating.

HEAT-CAP-FT

Takes the U-name of a curve the gives the heating capacity of the chiller as a function of the leaving hot water temperature and the entering air temperature, *when the air temperature is warm enough to prevent frost build-up on the heat-exchanger*. This curve should be normalized to 1.0 at the ARI or Eurovent rating point.

At air temperatures above 39°F (4°C), frost does not typically build up on the heat-exchanger. Below this temperature, frost build-up may be significant, and a defrost cycle is necessary. The no-frost/frost transition cannot be accurately modeled using a single bi-quadratic curve, so two curves are used.

HEAT-CAP-FT-FRST

Takes the U-name of a curve the gives the heating capacity of the chiller as a function of the leaving hot water temperature and the entering air temperature, *when the air temperature is cool enough that frost forms on the heat-exchanger*. This curve should be normalized to the capacity at the ARI or Eurovent rating point.

At air temperatures above 39°F (4°C), frost does not typically build up on the heat-exchanger. Below this temperature, frost build-up may be significant, and a defrost cycle is necessary. The no-frost/frost transition cannot be accurately modeled using a single bi-quadratic curve, so two curves are used.

HEAT-EIR

The ratio of electric input power to heating capacity at the standard heating rating conditions. The HEAT-EIR is dimensionless, so the same units for electric input and capacity must be used when calculating it.

The program uses the following relationship to calculate the electricity input to the chiller each hour when heating:

$$\begin{aligned} \text{Cap}_{\text{hour}} &= \text{Capacity} * \text{Heat/Cool Ratio} * \text{Cap f}(\text{Thws}, \text{OAT}) \\ \text{dT} &= \text{Thws} - \text{OAT} \\ \text{Elec}_{\text{hour}} &= \text{Cap}_{\text{hour}} * \text{EIR} * \text{EIR f}(\text{PLR}, \text{dT}) * \text{EIR f}(\text{Thws}, \text{OAT}) \end{aligned}$$

where

Thws	leaving hot-water temperature
OAT	entering outdoor air temperature
Cap _{hour}	hourly heating capacity
Capacity	rated cooling capacity, CAPACITY
Heat/Cool Ratio	ratio of rated heating capacity to rated cooling capacity, HEAT/COOL-CAP
Cap f(Thws,OAT)	correction to capacity for temperatures, curve HEAT-CAP-FT
Elec _{hour}	electric input to the chiller
EIR	rated electric input ratio, HEAT-EIR
EIR f(PLR,dT)	correction to EIR for part-load ratio, curve HEAT-EIR-FPLR
EIR f(Thws,OAT)	correction to EIR for temperatures, curve HEAT-EIR-FT

If you change any one of the above curves you should either change the others or verify that they are reasonable over the expected range of operating conditions.

HEAT-EIR-FT

Takes the U-name of a curve that adjusts the HEAT-EIR as a function of the leaving hot water temperature and the entering air temperature, *when the air temperature is warm enough to prevent frost build-up on the heat-exchanger*. This curve should be normalized to 1.0 at the ARI or Eurovent rating point.

At air temperatures above 39°F (4°C), frost does not typically build up on the heat-exchanger. Below this temperature, frost build-up may be significant, and a defrost cycle is necessary. The no-frost/frost transition cannot be accurately modeled using a single bi-quadratic curve, so two curves are used.

HEAT-EIR-FT-FRST

Takes the U-name of a curve that adjusts the HEAT-EIR as a function of the leaving hot water temperature and the entering air temperature, *when the air temperature is cool enough that frost forms on the heat-exchanger*. This curve should be normalized to 1.0 at the ARI or Eurovent rating point.

At air temperatures above 39°F (4°C), frost does not typically build up on the heat-exchanger. Below this temperature, frost build-up may be significant, and a defrost cycle is necessary. The no-frost/frost transition cannot be accurately modeled using a single bi-quadratic curve, so two curves are used.

HEAT-EIR-FPLR

Takes the U-name of a curve that adjusts the HEAT-EIR as a function of the heating part load ratio, and possibly the temperature differential between the hot-water supply temperature and the entering air temperature. The curve must be normalized to 1.0 at full load and rated heating temperatures.

Well-Water-to-Water Heat-Pump (HEAT-PUMP, WATER-COOLED)

A water-to-water heat pump serving a 2-pipe fan coil system is simulated using a chiller of TYPE = HEAT-PUMP and CONDENSER-TYPE = WATER-COOLED. When the 2-pipe circulation-loop is in the cooling mode, the unit acts identically to a water-cooled electric chiller. When the loop is in the heating mode, a changeover valve causes chiller to act as a heat pump, heating the loop by absorbing heat from a ground-water loop. In the heating mode, the chiller can deliver water as hot as 130°F. Note, however, that the maximum temperature varies with ground-water temperature.

In the cooling mode, the unit acts identically to an water-cooled electric chiller, and all keywords applicable to an electric chiller apply to this chiller type, with the following exceptions:

Condenser type – The CONDENSER-TYPE should be specified as WATER-COOLED. You may also specify AIR-COOLED, which is covered in a separate section. No other condenser types are acceptable. While the condenser of a conventional chiller can attach to loops of TYPE = CW, WLHP, or LAKE/WELL, this chiller can attach only to a loop of TYPE = LAKE/WELL.

Attachment to lake/well loop - The condenser keywords (CW-LOOP, CW-PUMP, CW-HEAD, etc.) are used in the same manner as for conventional chillers, and describe the attachment to the lake/well loop. In the heating mode, the condenser reverses its function and becomes the evaporator; drawing heat from the lake/well loop.

Heat recovery – This chiller is offered as a packaged self-contained unit, and heat recovery in the cooling mode is not available.

In the heating mode, the unit acts as a heat pump, and its performance may be significantly different than in the cooling mode. The following keywords define the unit's performance when heating. Note that, for the sake of consistency with other chillers, references to “condenser” in the following keywords refer to the heat-exchanger that rejects heat when in the cooling mode (the well-side heat-exchanger. This heat-exchanger is actually the evaporator in the heating mode, however the keywords still refer to it as a condenser, as this is the heat-exchanger coupled to the CW-LOOP.

Since this type of chiller is common in Europe, but not in the United States, the performance curves are normalized at the Eurovent rating conditions, rather than ARI.

DESIGN-HW-T

The leaving hot-water temperature at the heating design conditions. The default is the same as the DESIGN-HEAT-T of the 2-pipe loop to which this chiller is attached.

DESIGN-COND-T-HT

The entering lake/well temperature at the design heating conditions. The default is the DESIGN-HEAT-T of the lake/well loop.

CW-DT

The design temperature change of the lake/well water when in the cooling mode. The default is 90°F (32°C) minus the CW-LOOP:DESIGN-COOL-T. For example, if the design cooling temperature of the lake/well loop is 60°F, then the design temperature change will be 30°F.

The expansion valve of the heat pump is sized for the high pressure differential that normally exists in the heating mode. In the cooling mode, if 60°F water were to enter the heat pump with only a 10°F rise, then the condensing pressure would be too low to maintain refrigerant flow through the expansion valve. For this reason, flow is normally reduced through the condenser when in the cooling mode. This is accomplished via a solenoid valve in parallel with a restricting valve. During cooling, the solenoid valve is closed, and condenser flow is restricted through the balance valve (thereby achieving the CW-DT). During heating, the solenoid valve is open, allowing full flow.

CW-DT-HT

The design temperature change of the lake/well water when in the heating mode. The default is 9°F (5°C).

The expansion valve of the heat pump is sized for the high pressure differential that normally exists in the heating mode. In the cooling mode, if 60°F water were to enter the heat pump with only a 10°F rise, then the condensing pressure would be too low to maintain refrigerant flow through the expansion valve. For this reason, flow is normally reduced through the condenser when in the cooling mode. This is accomplished via a solenoid valve in parallel with a restricting valve. During cooling, the solenoid valve is closed, and condenser flow is restricted through the balance valve (thereby achieving the CW-DT). During heating, the solenoid valve is open, allowing full flow.

RATED-HW-T

specifies the leaving hot-water temperature at the rated conditions, either ARI or Eurovent (The default is for Eurovent). This is the value at which the heating mode performance curves are normalized. Normally, you should not change the default value of this keyword unless you are also specifying the heat-pump performance curves, and the curves are normalized to a different value.

RATED-COND-T-HT

The entering lake/well temperature when in the heating mode, at the rated heating conditions. This is the value at which the heating mode performance curves are normalized. Normally, you should not change the default value of this keyword unless you are also specifying the heat-pump performance curves, and the curves are normalized to a different value.

RATED-HT/CL-FLOW

specifies the ratio of the flow during heating to the flow during cooling at the rated conditions. Heating and cooling performance is usually rated at a constant CW-LOOP temperature change of 9°F (5°C). However, because the heat taken or rejected to the CW-LOOP is not the same in both modes, the rated flow used to develop the performance curves is different in each case; usually with the heating flow smaller than the cooling flow.

Normally, you should not change the default value of this keyword unless you are also specifying the heat-pump performance curves, and the curves are normalized to a different value.

HEAT/COOL-CAP

Is the ratio of the heating capacity to the cooling capacity at the standard rating conditions.

The chiller’s CAPACITY is the cooling capacity at the standard cooling rating conditions (SPECIFIED-AT = RATED-CONDITIONS). At the standard heating rating conditions, the heating capacity is usually very close to the cooling CAPACITY. If, however, the heating capacity was only 80% of the cooling capacity, then this keyword would have a value of 0.8

When the CAPACITY is allowed to default:

Cooling capacity - The program looks at the peak cooling requirement at the actual peak conditions, calculates the capacity at these conditions, and translates the capacity to the rated conditions.

Heating capacity – The program looks at the peak heating requirements at the actual peak heating conditions, calculates the heating capacity at these conditions, and translates the capacity to the rated conditions.

Greater of the two – The program takes the rated heating capacity and calculates an equivalent cooling capacity by dividing by the HEAT/COOL-CAP. The CAPACITY is the greater of the rated cooling capacity, or the equivalent cooling capacity required for heating.

HEAT-CAP-FT

Takes the U-name of a curve the gives the heating capacity of the chiller as a function of the leaving hot water temperature and the entering lake/well temperature. This curve should be normalized to 1.0 at the ARI or Eurovent rating point.

HEAT-EIR

The ratio of electric input power to heating capacity at the standard heating rating conditions. The HEAT-EIR is dimensionless, so that the same units for electric input and capacity must be used when calculating it.

The program uses the following relationship to calculate the electricity input to the chiller each hour when heating:

$$\begin{aligned} \text{Cap}_{\text{hour}} &= \text{Capacity} * \text{Heat/Cool Ratio} * \text{Cap f}(T_{\text{hws}}, T_{\text{wsw}}) \\ dT &= T_{\text{hws}} - T_{\text{wsw}} \\ \text{Elec}_{\text{hour}} &= \text{Cap}_{\text{hour}} * \text{EIR} * \text{EIR f}(\text{PLR}, dT) * \text{EIR f}(T_{\text{hws}}, T_{\text{wsw}}) \end{aligned}$$

where

- T_{hws} leaving hot-water temperature
- T_{wsw} entering lake/well water temperature
- Cap_{hour} hourly heating capacity
- Capacity rated cooling capacity, CAPACITY
- Heat/Cool Ratio ratio of rated heating capacity to rated cooling capacity, HEAT/COOL-CAP
- Cap f(T_{hws}, T_{wsw}) correction to capacity for temperatures, curve HEAT-CAP-FT
- Elec_{hour} electric input to the chiller
- EIR rated electric input ratio, HEAT-EIR
- EIR f(PLR, dT) correction to EIR for part-load ratio, curve HEAT-EIR-FPLR
- EIR f(T_{hws}, T_{wsw}) correction to EIR for temperatures, curve HEAT-EIR-FT

If you change any one of the above curves you should either change the others or verify that they are reasonable over the expected range of operating conditions.

HEAT-EIR-FT

Takes the U-name of a curve that adjusts the HEAT-EIR as a function of the leaving hot water temperature and the entering lake/well temperature. This curve should be normalized to 1.0 at the ARI or Eurovent rating point.

HEAT-EIR-FPLR

Takes the U-name of a curve that adjusts the HEAT-EIR as a function of the heating part load ratio. The curve must be normalized to 1.0 at full load.

Loop-to-Loop Heat-Pump (LOOP-TO-LOOP-HP)

This chiller is attached to a both a chilled-water loop and a hot-water loop (Figure 30). The chiller actively supplies cooling and/or heating to the two loops. A lake/well water loop supplies the necessary heat balance via two heat-exchangers in series with the evaporator and condenser loops.

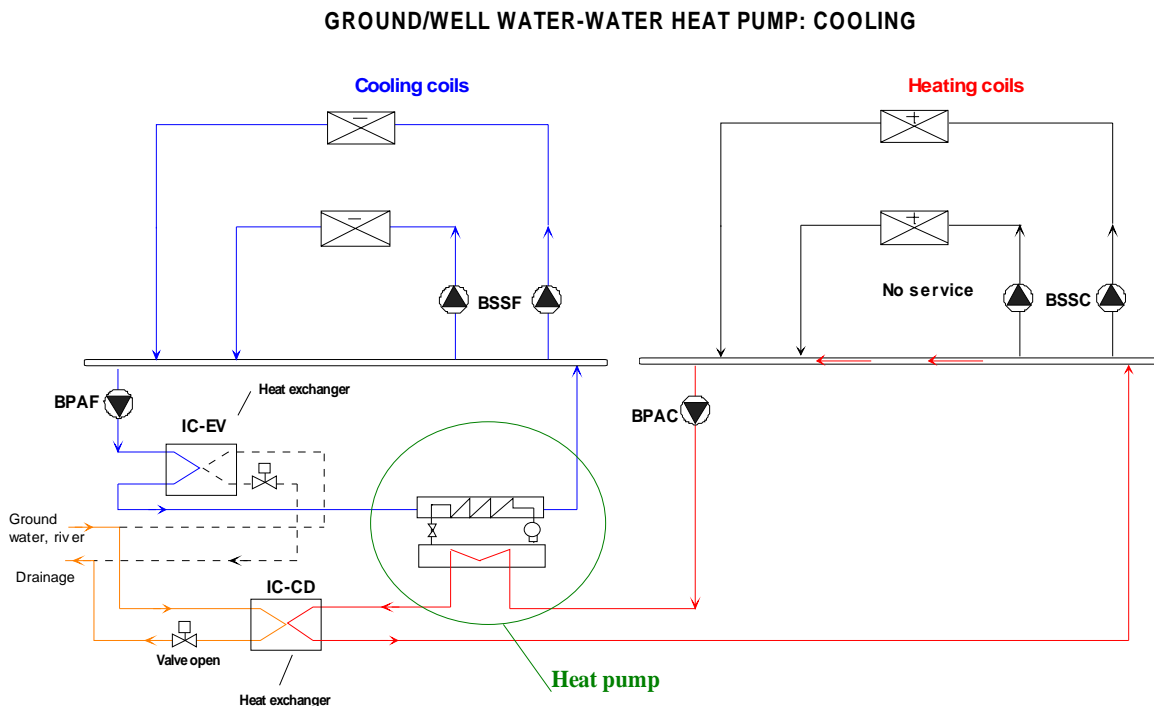

Figure 30. Loop-to-Loop Heat Pump

The chiller requires both evaporator and hot-water pumps, and these pumps must be able to operate independently of the chilled and hot-water loops. For this reason, the chilled-water and hot-water loops must have their own pumps, in addition to the chiller pumps. The evaporator and condenser pumps operate in a constant-flow mode, variable-flow operation is not permitted. However, the circulation-loop chilled-water and hot-water loop pumps may be either constant-flow or variable-flow.

The lake/well-water loop (condenser loop) interfaces with the two heat-exchangers. It can be pumped identically as described for other chillers. Most commonly, the lake/well loop will have its own pump. However, the chiller may have a condenser pump in addition to, or in lieu of, the well pump. If the condenser pump is in lieu of a pump directly attached to the lake/well loop, then it will power the loop. Otherwise it will act only to overcome the head of the chiller’s heat-exchangers. The condenser flow may be modulated using either two-way or three-way valves, the default is two-way, resulting in variable –volume condenser flow.

The following describes the four modes of operation. In all four modes, both the evaporator and hot-water pumps must run to circulate fluid through the evaporator and condenser.

Cooling only (Figure 31) – In this mode, the chiller tracks the demand of the chilled-water loop. The heat is rejected from the hot-water loop to the well-water loop via heat-exchanger IC-CD. The heat-exchanger is controlled to maintain a leaving hot-water temperature of approximately 85°F (leaving the heat-exchanger; entering the chiller condenser).

GROUND/WELL WATER-WATER HEAT PUMP: COOLING

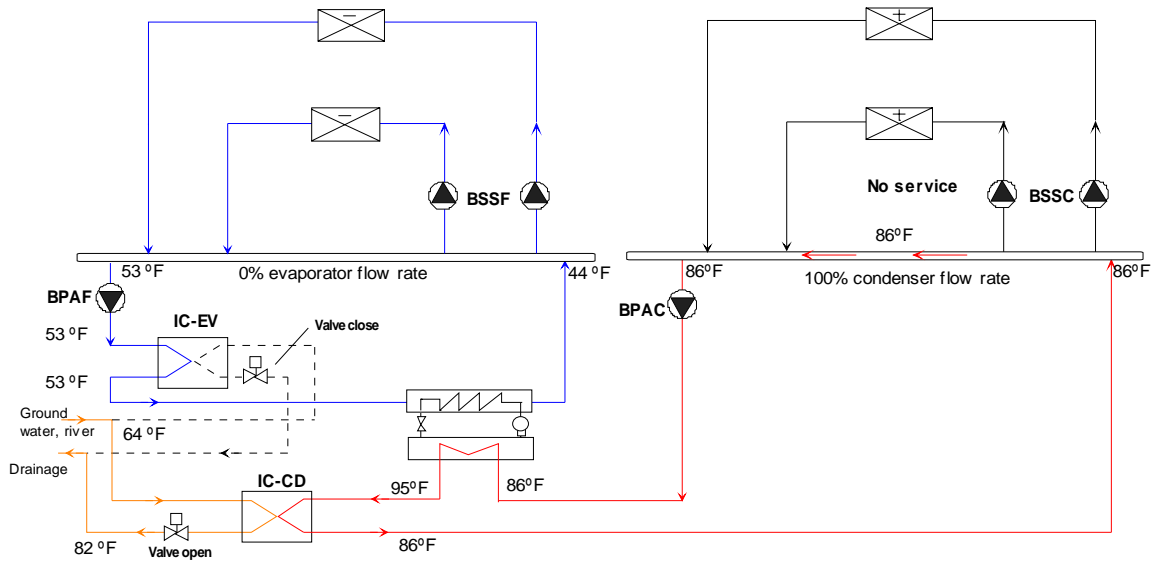

Figure 31. Loop-to-Loop Heat Pump Cooling Only

Heating only (Figure 32) – In this mode, the chiller acts the same as a boiler and tracks the demand of the hot-water loop. Heat is made up from the well-water loop to the evaporator loop via heat-exchanger IC-EV. The heat-exchanger is controlled to maintain a leaving chilled-water temperature of approximately 53°F (leaving the heat-exchanger, entering the evaporator).

WATER-WATER HEAT PUMP: HEATING

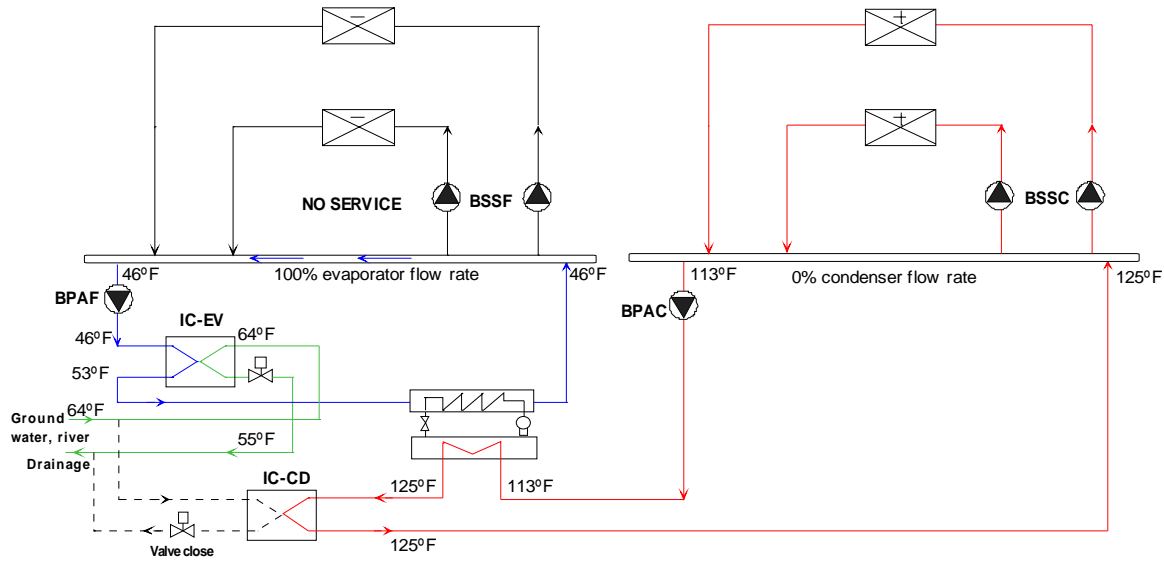
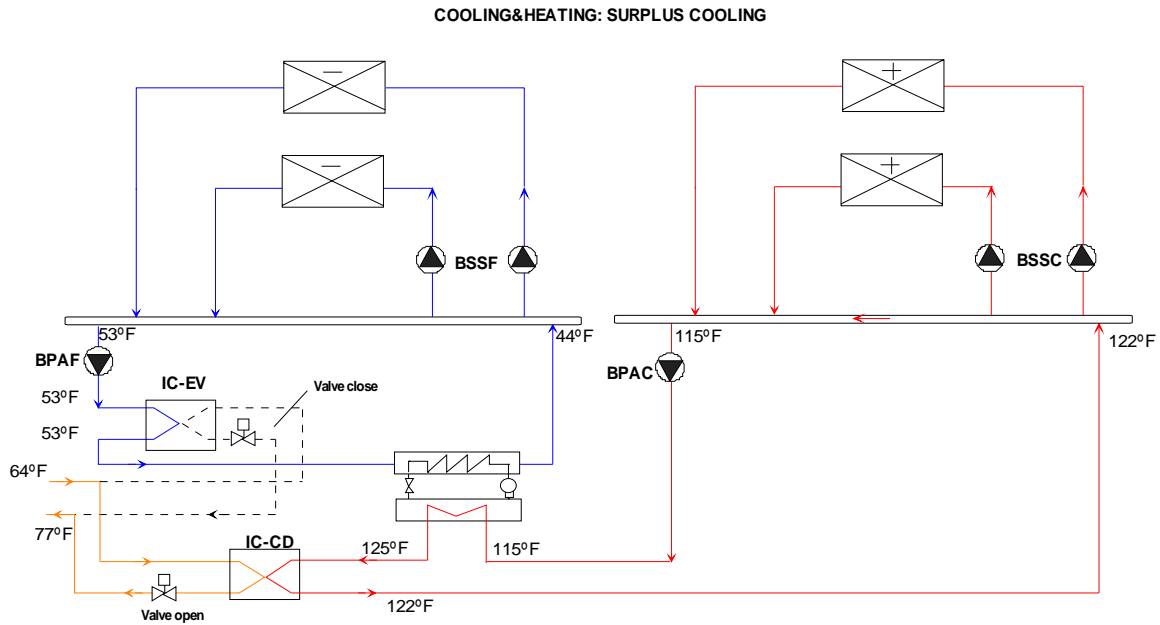

Figure 32. Loop-to-Loop Heat-Pump Heating Only

Cooling dominated (Figure 33) – Simultaneous heating and cooling loads exist, with cooling being the dominant load. Excess heat is rejected from the hot-water loop via heat-exchanger IC-CD. The heat-exchanger is controlled to maintain the supply temperature of the hot-water loop. Since the temperature returning from the hot-water loop and entering the condenser may be substantially higher than in the cooling-only mode, the capacity and energy efficiency of the chiller are reduced.



**Figure 33. Loop-to-Loop Heat-Pump
Cooling Dominated**

Heating dominated (Figure 34)– Simultaneous heating and cooling loads exist, with heating being the dominant load. Additional heat from the well loop is made up to the evaporator loop via heat-exchanger IC-EV. The heat-exchanger is controlled to maintain the supply temperature of the chilled-water loop. Since the temperature leaving the evaporator may be substantially lower than in the heating-only mode, the capacity and energy efficiency of the chiller are reduced.

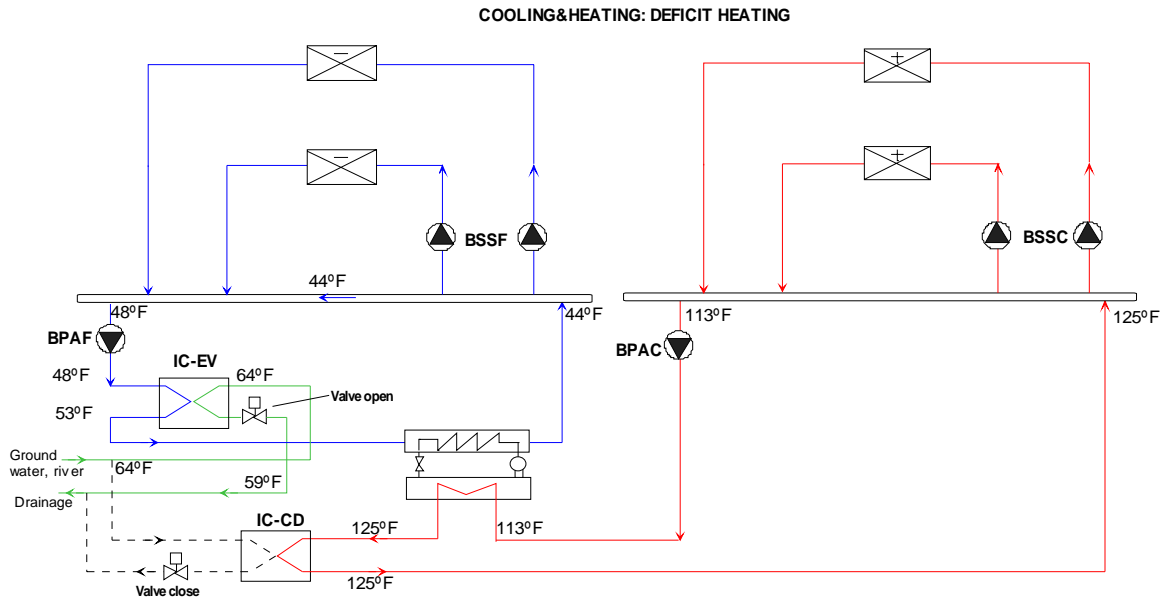

Figure 34. Loop-to-Loop Heat-Pump Heating dominated

Most of the keywords for this chiller are identical to the keywords used for conventional electric chillers. The following summarizes the differences:

Condenser type – The CONDENSER-TYPE is not used, as the condenser is always water-cooled. While the condenser of a conventional chiller can attach to loops of TYPE = CW, WLHP, or LAKE/WELL, this chiller can attach only to a loop of TYPE = LAKE/WELL.

Attachment to lake/well loop- The condenser keywords (CW-LOOP, CW-PUMP, CW-HEAD, etc.) are used in the same manner as for conventional chillers, and describe the attachment to the lake/well loop. The chiller may either draw heat from or reject heat to the lake/well loop, depending on whether the chiller is cooling or heating dominated.

Hot and chilled-water pumps– As described previously, this chiller must have dedicated evaporator and condenser-water pumps, which operate in either a constant-flow mode. The loops they serve must have their own pumps, which may be either constant-flow or variable-flow. The well-water attachment (CW-LOOP, etc.), may optionally have a condenser pump, which may be in lieu of the well loop pump, and by default is variable-flow.

Heat-recovery loop – This chiller actively heats a HW loop, similar to a boiler. Therefore, the heat-recovery keywords (HTREC-LOOP, etc.) are not valid.

Performance data – Unlike the two-pipe heat-pump chiller (HEAT-PUMP), this chiller does not have a reversing valve; all heating/cooling effects are controlled via the two well-water heat-exchangers. For this reason, the program can use the cooling performance curves that describe the evaporator and

compressor motor performance to calculate the resulting heating performance. In other words, there is no separate set of keywords that describe the chiller performance when in the heating mode. It is critical that the performance curves be valid over the entire range of evaporator and hot-water temperatures which may be encountered.

For example, consider a chiller attached to a lake, operating in the heating mode in the winter. If the entering lake-water temperature is 45°F, then the leaving evaporator temperature may be on the order of 35°F. Simultaneously, the hot-water return temperature (entering condenser-water temperature) may be on the order of 120°F. The performance curves must be valid for this extreme range.

Since this type of chiller is common in Europe, but not in the United States, the performance curves are normalized at the Eurovent rating conditions, rather than ARI.

DESIGN-HW-T

The leaving hot-water temperature at the heating design conditions. The default is the same as the DESIGN-HEAT-T of the hot-water loop to which this chiller is attached.

DESIGN-COND-T

The entering condenser temperature at the design *cooling* conditions. This is the temperature leaving the condenser-side heat-exchanger and entering the chiller condenser. The default is the DESIGN-COOL-T of the lake/well water loop, plus 5°F.

When autosizing a chiller, the default assumes that heating does not occur simultaneously with peak cooling. If heating does occur simultaneously with peak cooling, change this value to approximate the hot-water return temperature at the peak cooling conditions.

The following keywords describe the properties of the heat-exchangers. The heat-exchangers are assumed to be counterflow.

EVAP-HX-DESIGN-T

The design temperature of the water leaving the evaporator-side heat-exchanger (heating mode). The default is the DESIGN-HEAT-T of the lake/well loop, minus 5°F. This value is used in the design heating calculations.

EVAP-HX-SETPT-T

When the chiller is in the heating-only mode and heat-exchanger IC-EV is adding heat to the evaporator loop, specifies the temperature setpoint of the chilled-water *leaving* the heat-exchanger and entering the evaporator. The default is the same as the EVAP-HX-DESIGN-T.

The program uses this setpoint, together with the hourly load, UA product and chilled-water flow, to calculate the chilled-water temperature and required well-water flow. Note that this setpoint may not be maintained if the well-water is too cold. For example, if the setpoint is 60°F but the well-water is only 50°F, then it will be impossible to meet the setpoint, and the evaporator temperature will float somewhere below 50°F.

This keyword applies to the *heating-only* mode. In all other modes involving cooling, the heat-exchanger is controlled so that the temperature requirement of the chilled-water loop (chilled-water supply temperature) is met.

EVAP-HX-TD

is the design temperature differential between the chilled-water and well-water streams *entering* the evaporator-side heat-exchanger (IC-EV in the diagrams). The differential is the differential when the chiller is operating in the heating-only mode, which represents maximum heat-exchanger loading. The program uses this value, together with

the design evaporator load in the heating mode, and the design chilled-water and well-water flows, to calculate the UA product of the heat-exchanger.

The default is calculated as

$$TD = T_{well} - (T_{setpt} + dT_{chw})$$

where

TD	the design entering temperature differential
T _{well}	the DESIGN-HEAT-T of the well water loop
T _{setpt}	the EVAP-HX-SETPT-T
dT _{chw}	the design chilled water temperature rise, CHW-DT

COND-HX-SETPT-T

When the chiller is in the cooling-only mode and heat-exchanger IC-CD is removing heat from the hot-water loop, specifies the temperature setpoint of the hot-water *leaving* the heat-exchanger and entering the condenser. The default is the same as the DESIGN-COND-T.

The program uses this setpoint, together with the hourly load, UA product and chilled-water flow, to calculate the condenser-water temperature and required well-water flow. Note that this temperature may not be maintained if the lake/well-water is too warm. For example, if the setpoint is 75°F but the chiller is attached to a lake that peaks at 80°F, then it will be impossible to meet the setpoint.

This keyword applies to the *cooling-only* mode. In all other modes involving heating, the heat-exchanger is controlled so that the temperature requirement of the hot-water loop (hot-water supply temperature) is met.

COND-HX-TD

is the design temperature differential between the hot-water and well-water streams *entering* the condenser-side heat-exchanger (IC-CD in the diagrams). The differential is the differential when the chiller is operating in the cooling-only mode, which represents maximum heat-exchanger loading. The program uses this value, together with the design condenser load in the cooling mode, and the design hot-water and well-water flows, to calculate the UA product of the heat-exchanger.

The default is calculated as

$$TD = T_{setpt} + dT_{cw} - T_{well}$$

where

TD	the design entering temperature differential
T _{setpt}	the COND-HX-SETPT-T
dT _{cw}	the design condenser-water temperature rise, CW-DT
T _{well}	the DESIGN-COOL-T of the well water loop

Chiller Water-Economizer

A water-side economizer provides “free cooling” by allowing cooling tower water to bypass the chiller(s) and directly cool a chilled-water loop. The cooling is not actually “free”, as energy must still be expended in the cooling tower fans and pumps. Water-side economizers may be divided into three principal configurations:

Direct injection – The condenser water is filtered and directly injected into the chilled-water loop. While this method maximizes the effectiveness of the economizer, it introduces oxygen and other contaminants into the piping. These contaminants may ultimately corrode and/or foul the piping and coils; thereby degrading the performance of the system and shortening its life.

Indirect heat-exchanger – A plate-and-frame heat-exchanger to indirectly cool the chilled-water loop. The heat-exchanger prevents the relatively dirty condenser water from fouling the chilled-water components. Since the effectiveness of a heat-exchanger is always less than 1.0, this method cannot achieve the same performance as direct injection.

Thermocycle – A chiller can be configured so that its heat-exchangers and refrigerant act as a passive heat transfer mechanism. Like the indirect method, this method prevents cross-contamination of the chilled and condenser loops. However, it does not usually achieve the same cooling capacity for a given temperature differential.

The capability to simulate a water-side economizer was omitted from earlier versions of DOE-2 because of the lack of funding necessary to implement this component properly. Nevertheless, many high-rise buildings utilize water-side economizers, and many users have expressed the need to simulate these components.

The program now partially remedies this problem by introducing a new type of chiller that is a simple plate-and-frame heat-exchanger. This is not a complete implementation, and the following rules must be understood:

The program assumes a water-side economizer is used in an “all or nothing” mode. If the water-side economizer can handle the entire cooling load, then it will be used. Otherwise, the loop will use its other chillers. A water-side economizer cannot precool the return flow prior to entering the chillers.

The “all or nothing” mode precludes the use of an EQUIP-CTRL sequence to coordinate the operation of an economizer chiller with other chillers. If you list a water-side economizer chiller in an EQUIP-CTRL sequence, it will be ignored.

There must be a one-to-one correspondence between a CHW loop, a water-side economizer, and a CW loop. A CHW loop may be supplied by only one water-side economizer, and a CW loop may supply only one water-side economizer. In other words, a plant may have any number of chilled water loops having water-side economizers, but those economizers cannot draw from the same CW loop. The program will generate an error if this condition is not met.

If a CW loop supplies a water-side economizer, it may also supply chillers serving the same CHW loop as the economizer. However, it cannot supply chillers serving other CHW loops. The program will generate an error if this condition is not met.

A CW loop supplying a water-side economizer should have only one cooling tower. More than one cooling tower is allowed, however only the first tower defined will be checked to see if sufficient free cooling capacity is available. Once free cooling is allocated to a CW loop, the program may use any combination of towers to satisfy it. *The program may underpredict the water-side economizer savings if more than one cooling tower serves a given CW loop. To minimize the underprediction, define the largest tower first.*

If there is any water-cooled packaged equipment in the SYSTEM command, this equipment will be ignored when determining whether the tower has sufficient free cooling capacity. *This may cause the program to overpredict water-side economizer savings.*

For maximum effectiveness, the CHW loop should have COOL-SETPT-CTRL = LOAD-RESET. This allows the CHW temperature setpoint to rise during periods of low loads, maximizing the effectiveness of the water-cooled economizer.

WATER-ECONO-EFF

for a WATER-ECONOMIZER, specifies the effectiveness of the heat-exchanger. The simple heat-exchanger model in this component assumes a constant effectiveness for all chilled-water and condenser-water flows. It is used in the following equation for load:

$$Q_{\text{econo}} = M_{\text{chw}} * C_{\text{pchw}} * \text{Eff} * (T_{\text{return}} - T_{\text{cw}})$$

where

Q_{econo}	maximum load the economizer can handle
M_{chw}	chilled-water mass flow rate
C_{pchw}	chilled-water specific heat
Eff	heat-exchanger effectiveness
T_{return}	chilled-water return temperature
T_{cw}	condenser-water supply temperature

The default effectiveness is 0.8. To model direct-injection (strainer cycles), specify an effectiveness of 1.0.

Miscellaneous

COST-DATA

Takes the U-name of a MATERIALS-COST command, which allows you to define first costs, maintenance costs, etc. for this chiller.

EQUIPMENT-REPORTS

Takes the code-words YES or NO. When report PS-H of the PLANT-REPORTS is enabled, a report will print for the chiller unless this keyword is set to NO.

CHW-METER

Defines the parameters for a meter that supplies chilled water from a utility. This meter attaches to a loop and provides the required cooling to the loop. The meter may meet all of the load (no other cooling equipment attached to the loop), or be coordinated with other primary equipment to provide only part of the load. The program passes the meter consumption data to the ECONOMICS program so that costs can be determined.

Rules:

Multiple CHW-METERs may be defined.

Any given loop can have at most one CHW-METER attached to it. A 2-pipe loop may have a CHW-METER and a STEAM-METER attached to it.

If you define a UTILITY-RATE of TYPE = CHILLED-WATER, but do not list the meters, the default will be all meters of the correct type.

A meter may be the sole source of energy to a CIRCULATION-LOOP, or there may also be other equipment (boilers, chillers, etc.) By default, the program will allocate as much of the loop load to the primary equipment as possible, with the meter making up the remainder. You can override this default control sequence by defining an EQUIP-CTRL sequence for the loop.

CIRCULATION-LOOP

Takes the U-name of the CIRCULATION-LOOP to which this meter is attached. The loop must be of a compatible type. For example, a CHW-METER can attach to chilled-water loop but not a hot-water loop.

CAPACITY

The size of the meter service. The program assumes that the capacity of the meter is limited by the piping serving the site, and that any loads larger than this capacity will result in an overload condition. If you do not specify this keyword, the capacity will default to the loop capacity, adjusted by the CAPACITY-RATIO. If no CAPACITY-RATIO is input, then the capacity will default to the loop capacity.

CAPACITY-RATIO

If CAPACITY is not entered, this is the fraction of the design loop capacity that the meter will be sized to meet.

ENERGY/UNIT

The size of the billing unit in Btu or Wh in which consumption is measured.

UNIT-INDEX

An integer value that defines the billing unit as listed in the units table (see Appendix A). This value is used in the reports, and allows English units to be converted to the correct metric units. The default is 50, which corresponds to MBtu in English units and MWh in metric units.

DEM-UNIT-INDEX

An integer value that defines the billing unit of peak demand as listed in the units table (see Appendix A). This value is used in the reports and allows English units to be converted to the correct metric units. The default is 34, which corresponds to MBtu/hr in English units and MW in metric units.

SOURCE-SITE-EFF

The ratio between the energy delivered to the building site and the source energy (the energy used by the utility to generate the energy delivered to the building).

INTERIOR-POWER

Accepts a list of up to 10 values of hourly energy consumed by miscellaneous uses inside the building that do not show up anywhere else. This energy shows up as a load on the meter, but does not appear as either a space load or as a circulation loop load. Note that most process loads should be entered as such on a CIRCULATION-LOOP, rather than here. This is so that the program can account for thermal losses and pumping energy. Use INTERIOR-SCH, below, to schedule interior power.

INTERIOR-SCH

Accepts a list of up to 10 U-Names of schedules with TYPE = MULTIPLIER that modify the INTERIOR-POWER values on an hourly basis.

INTERIOR-EU

Accepts a list of up to 10 code-words specifying the end-use category of the INTERIOR-POWER. The code-words correspond to the end-use categories in the end-use reports (PS-E, PS-F, BEPS, BEPU). Acceptable entries are LIGHTS, TASK-LIGHTS, MISC-EQUIP, SPACE-HEATING, SPACE-COOLING, HEAT-REJECT, PUMPS&AUX, VENT-FANS, REFRIG-DISPLAY, HT-PUMP-SUPPLEM, DOMEST-HOT-WTR, and EXT-USAGE.

Note that, while exterior energy can be entered via the EXTERIOR-POWER keyword, it may also be entered via the INTERIOR-POWER and INTERIOR-EU = EXT-USAGE keywords.

EXTERIOR-POWER

Accepts a list of up to 10 values of hourly energy consumed by miscellaneous uses outside the building that do not show up anywhere else. This energy shows up as a load on the meter, but does not appear as either a space load or as a circulation loop load. Note that most process loads should be entered as such on a CIRCULATION-LOOP, rather than here. This is so that the program can account for thermal losses and pumping energy. Use EXTERIOR-SCH, below, to schedule exterior power.

EXTERIOR-SCH

Accepts a list of up to 10 U-Names of schedules with TYPE = MULTIPLIER that modify the EXTERIOR-POWER values on an hourly basis.

EXTERIOR-EU

Accepts a list of up to 10 code-words specifying the end-use category of the EXTERIOR-POWER. The code-words correspond to the end-use categories in the end-use reports (PS-E, PS-F, BEPS, BEPU, TDV1 TDV2). Acceptable entries are LIGHTS, TASK-LIGHTS, MISC-EQUIP, SPACE-HEATING, SPACE-COOLING, HEAT-REJECT, PUMPS&AUX, VENT-FANS, REFRIG-DISPLAY, HT-PUMP-SUPPLEM, DOMEST-HOT-WTR, and EXT-USAGE.

Note that, while exterior energy can be entered via the EXTERIOR-POWER keyword, it may also be entered via the INTERIOR-POWER and INTERIOR-EU = EXT-USAGE keywords. The same is true for REFG-POWER.

HX-HEAD

The pressure drop through the meter's heat-exchanger, if one exists. The default value assumes that there is no heat-exchanger, i.e., that the building uses chilled water directly.

HX-STATIC-HEAD

The static head that the meter creates on the loop (non-varying with flow). Normally, this value will be zero for virtually all systems.

METER-REPORT

Accepts code-words YES and NO. When report PS-F of the PLANT-REPORTS is enabled, a report will print for this meter unless this keyword is set to NO.

CIRCULATION-LOOP

Defines the operating parameters of a fluid (usually water) circulation loop. U-name is required. This U-name will be referenced by any pumps, primary equipment, and coils attached to this loop. It is also used as the identifier in the heading of the loop report.

A CIRCULATION-LOOP command must precede the input of any element (such as a zone, system or plant component) that is attached to the loop.

Example Input:

```
HEATING-LOOP-1 = CIRCULATION-LOOP
  TYPE          = HW
  LOOP-PUMP     = "HEATING PUMP" . .
```

TYPE

Takes a code-word that specifies the type of the loop. This is a required keyword. Acceptable values are:

- | | |
|-------|---|
| CHW | A chilled-water loop. On the demand side a CHW loop attaches to cooling coils or to process cooling loads defined within a space. On the supply side this loop attaches to chillers and/or a chilled-water utility. |
| HW | A hot-water loop. On the demand side a hot-water loop attaches to heating coils, preheat coils, reheat coils, baseboard heaters, floor panels, supplementary heating loads (from a heat pump), or to process heating loads defined within a space. It may also attach to an absorption chiller. On the supply side this loop attaches to boilers, heat-recovery devices, and/or a hot-water/steam utility. |
| PIPE2 | A 2-pipe heating and cooling loop. A 2-pipe loop supplies both chilled water and hot water to coils, but never during the same hour. When the loop is in the heating mode, any cooling loads which may coexist will not be met, and the temperature of the zones that demand cooling will float accordingly. The same is true for heating loads once the loop has switched over to cooling. The loop may switch from heating to cooling on the basis of an indoor or outdoor temperature, or according to a schedule. You specify the switching parameters using the LOOP-OPERATION keyword. The demand and supply connections are any of the connections defined for the HW and CHW loop types. |
| WLHP | A water-loop heat-pump loop. A WLHP loop is primarily intended to serve water-loop heat-pump systems (system type HP). Individual WLHP units operate according to their zone thermostats, and reject heat to or take heat from this loop. Depending on the relative number of units operating in the heating or cooling mode, the loop will be thermally unbalanced and the loop temperature will either rise or fall. One or more boilers and one or more cooling towers operate to keep the loop within specified limits. In addition to WLHP units, any cooling unit with a water cooled condenser may be assigned to this loop. For example, a DX cooling unit serving a computer room can reject its heat to a WLHP loop so that the computer room heat can be recovered by a WLHP unit. Chillers may also be assigned to this loop, although this is uncommon. On the demand side a WLHP loop attaches to WLHP units, to water-cooled DX cooling units, or chillers. On the supply side this loop connects to boilers, cooling-towers, heat-recovery devices, and/or hot-water utility, and/or a chilled-water utility. |

DHW	A domestic hot water loop that supplies potable heated water to kitchens, bathrooms, etc. Heating coils may also attach. This is sometimes done in apartments or small houses located in relatively mild climates. The water heater then provides heat both for domestic purposes as well as space heating. On the supply side this loop attaches to DHW heaters, boilers, or to a hot-water/steam utility.
CW	A condenser water loop. A CW loop takes the heat rejection loads of chillers, packaged direct expansion (DX) HVAC systems with water-cooled condensers, water-side economizers, and electrical generators. The loop rejects the condenser heat to one or more cooling towers.
LAKE/WELL	A loop that circulates ground water from a lake or well to a chiller condenser. A GROUND-LOOP-HX of TYPE = LAKE/WELL provides the water to this loop.

SUBTYPE

Takes a code-word defines the subtype of the loop. Acceptable entries are:

PRIMARY	Is the most basic loop, and the only mandatory component of a loop system. A primary loop can serve the demands of zero or more coils and zero or more secondary loops. It may also have zonal process loads attached, as well as a process load not specific to any zone (such as a manufacturing load). To meet these loads, the primary loop may have zero or more pieces of central plant equipment attached, or be attached to the appropriate utility energy source. A primary loop always has a pump, and always has a temperature control setpoint.
SECONDARY	<p>Defines a loop that is identical to a primary loop, except that it is supplied by a primary loop rather than primary central plant equipment. A secondary loop may have zero or more coils attached, as well as the process loads not specific to any zone (such as a manufacturing load). It is attached to a primary loop that handles all of the secondary loop loads. A secondary loop may not be attached to another secondary loop.</p> <p>A secondary loop may or may not have its own circulation pumps. When a secondary pump exists, the secondary loop may have its own operation schedules and temperature setpoints, subject to the availability and temperature of the energy in the primary loop. When a secondary pump does not exist, then the secondary loop operates in a purely passive fashion: it passes its load, temperature, flow, and head requirements onto the primary loop. This pump-less secondary loop is in actuality an extension of the primary loop; its main value is in allowing different legs of a primary loop to be in different zones so that the program can more accurately model the thermal losses. In addition, the coil and piping head losses can be assigned more accurately.</p>

DESIGN-HEAT-T

For loops that can heat, specifies the design hot-water supply temperature. This value may be used in the design calculations for various components, such as boilers and chillers.

For a LAKE/WELL loop this is the design temperature used for components that draw heat from the loop, such as a CHILLER of TYPE = HEAT-PUMP. As such, this value should represent the winter condition.

DESIGN-COOL-T

For a loop that can cool, specifies the design chilled-water temperature. This value is used in the design calculations for various components, such as chillers.

For a CW and WLHP loops, this is the design temperature that the cooling towers or fluid coolers can deliver. For LAKE/WELL loops, this is the design temperature used for components that reject heat to the loop; as such this value should represent the summer condition.

LOOP-DESIGN-DT

The design temperature change of the loop. This value is used in calculating the flow when the loop is sized based on the primary equipment. In addition, this keyword acts as the default temperature change through a coil if that change was not defined within the secondary HVAC system, and also as the default temperature change for the attached primary equipment.

To illustrate the overall default hierarchy, consider a reheat coil in a zone. If you do not specify the HW-COIL-DT at the ZONE level, then it will default to the HW-COIL-DT at the SYSTEM level. However, if you did not specify this value at the SYSTEM level either, then the temperature change through the reheat coil defaults to the attached LOOP-DESIGN-DT.

For a HW loop, the default recognizes that lower temperature loops typically have smaller temperature drops through the loads than higher temperature loops. DESIGN-HEAT-T. At a DESIGN-HEAT-T of 180°F, the dT is assumed to be 40°F (180°F supply, 140°F return). At 120°F, the dT is assumed to be 10°F. The dT varies linearly between these limits.

SIZING-OPTION

Takes a code-word that specifies which sizing method is to be applied to the loop. Acceptable values are:

SECONDARY	Specifies that the design loop load is to be based on the design loads of the coils, processes, etc., that are attached. Design flows are also taken from the secondary equipment.
PRIMARY	Specifies that the design loop load is to be based on the sum of the primary equipment capacities that are attached to this loop. In order for this code-word to be valid, you must enter the capacity of the boilers, chillers, etc. that supply this loop. Otherwise, the program will give a warning message that this keyword will be ignored, and will size the loop based on the secondary loads instead.

LOOP-SIZE-RATIO

The safety factor for loop sizing. (Note that safety factors could have already been specified within the secondary HVAC systems attached to this loop). This keyword is used only when SIZING-OPTION = SECONDARY-EQUIP; it is ignored for the PRIMARY-EQUIP sizing method. When primary equipment is to be auto-sized by the program, this keyword modifies the default capacity assigned. Note that this keyword affects only the auto-sizing of the primary equipment based on secondary loop loads. It has no effect on the design loop flow; the loop flow is based on the sum of the coil flows or other loads attached to the loop. However, the design pump flow can be modified via keywords in the PUMP command.

Loop Fluid and Flow Characteristics

The following set of keywords define some of the fluid and flow characteristics of the loop:

FLUID-VOLUME

The total volume of the fluid in the loop. Used to determine the heat capacity of the loop, which is used to modify the loop loads as the loop temperature changes.

AVG-CIRC-TIME

The average time it takes for the fluid to circulate through the loop at the design flow rate. When the FLUID-VOLUME is not defined, the program calculates a default volume based on the design flow rate multiplied by the circulation time. For example, assume the loop's design flow rate is 100 gallons/min (378 liters/min). If the average circulation time is 3.0 minutes, then the total loop volume is 100 gallons/min * 3.0 min = 300 gallons (or 378 liters/min * 3.0 min = 1134 liters).

LOOP-MIN-FLOW

The minimum flow fraction in the loop. The meaning of this keyword varies depending on the type of loop:

For all loops except DHW, the default is 0.05. For loops serving coils with 3-way valves or constant-flow condensers, the loop flow will be constant, and this keyword has no meaning. For loops serving coils with 2-way valves or water-cooled condensers having condenser valves, the loop flow will be variable and may drop to a very small fraction of the design load, or even zero. When this happens, the circulation pump may cause a very large temperature rise in the fluid, or may overheat and fail. The LOOP-MIN-FLOW prevents this from happening by opening a bypass valve as required to maintain the minimum loop flow. An alternate way of preventing this problem would be to assign 3-way valves to one or more of the coils attached to this loop.

For DHW loops having a recirculation pump, the default is zero. This keyword specifies the minimum fraction of design flow in the *supply* leg of the loop. As the process flow varies, (the flow assumed to go down the drain), the return flow will be modulated so that the resulting supply flow does not drop below this value. For example, if the design process flow is 15 gpm and this keyword is 0.33, then the minimum flow in the supply leg will be 5 gpm. If the process flow is currently 2 gpm, then 3 gpm will bypass into the return leg so that the supply flow is 5 gpm. If the process flow is 10 gpm, then no flow will pass into the return leg, and the circulation pump will be off.

This control strategy is useful in minimizing circulation pump energy consumption, and thermal losses in the return leg. To model a constant recirculation flow, specify the LOOP-RECIRC-FLOW.

LOOP-RECIRC-FLOW

The flow that recirculates in the loop at all times that the pump is running. The meaning of this keyword varies depending on the type of loop:

For all loops other than DHW, this value represents the flow through a constant-flow device (such as a Griswold) that bypasses fluid from the supply directly back to the return. In these types of loops, this is another method that can be used to ensure that a variable-volume loop never has a zero-flow condition. Note that the amount of fluid bypassed is constant every hour.

For a DHW loop, this value represents the flow that returns to the water heater, and is usually the only flow in the return leg (unless an HVAC coil is also attached). This is commonly done to keep the loop supply leg hot. This keyword is mandatory when a DHW loop has a pump, however you may specify a value of 0.0, in which case there is no recirculation flow. However, you must provide for some return flow, as the pump is assumed to act only on the return flow, not the supply. Return flow may also be provided via the LOOP-MIN-FLOW (variable-flow recirculation), or by attaching one or more of the airside HW-LOOPS to this loop.

PIPE-HEAD

The pressure loss of the piping due to friction. The default value is $\text{AVG-CIRC-TIME} * 14.4 \text{ ft/min} + 5.0 \text{ ft}$ ($\text{AVG-CIRC-TIME} * 4.39 \text{ m/min} + 1.52 \text{ m}$). The factor of 14.4 ft/min (4.39 m/min) is based on an average pipe size of 2 in (5.1 cm), 4 ft/s (1.22 m/s) average fluid velocity, and a head loss of 3 ft / 100 ft (0.91 m / 30.5 m), doubled for fittings. The default AVG-CIRC-TIME is 1.5 min, yielding a default PIPE-HEAD of 26.6 ft (8.1 m). This value represents the head of the piping and pump trim. You specify the head of the coils and of the primary equipment in the definitions of those components.

STATIC-HEAD

The pump head that is independent of fluid flow. A pump incurs static head when it must move a fluid that is at atmospheric pressure into a loop that is pressurized. Such loops are called open loops and may be encountered where open cooling towers are used, or in some thermal storage systems. A typical hot- or chilled-water loop is a closed loop and does not have any static head. For example, assume that a thermal storage tank is at ground level and is not pressurized (it is at atmospheric pressure). Fluid is to be moved from this tank to an air-handler coil in the penthouse of a five-story building (70 ft [21.3 m]) above the fluid level in the storage tank). The residual pressure at the coil is to be 15 psig (103.3 kPa). The static head of this system is

$$\text{Static} = 70 \text{ ft} + 15 \text{ psig} * 2.3 \text{ ft/psig} = 104.5 \text{ ft} \quad (21.34 \text{ m} + 103.3 \text{ kPa} * 0.102 \text{ m/kPa} = 31.88 \text{ m})$$

It is important that static heads be specified correctly where they exist, as they can have a major effect on the annual energy consumption of the pump. When the static head is equal to the friction head, a variable-speed pump will have to run at 70% speed just to overcome the static head in a no-flow condition; all non-zero flows will require a greater speed. The program takes the effect of static head into account when computing pump speeds. It is also important that a static head be specified only for the pump that incurs the head. If the static head is specified in more than one place, the head will be double-counted. For example, assume that the thermal energy storage tank described above has its own pump, separate from the loop pump. The tank pump injects fluid into the (pressurized) loop, and the loop pump circulates the fluid to the coils. In this case, the circulating loop is closed and does not have a static head (even though some of the coils may be on the top of buildings). The tank loop is open and experiences the static head described previously. In this example, the static head should be specified only in the definition of the tank's pump, not the circulation loop pump. Static heads can often be reduced or eliminated by coupling equipment to loops via a HEAT-EXCHANGER (heat-exchanger not implemented in current version).

Secondary Loop to Primary Loop Connection

The following set of keywords describes the connection between a secondary loop and its primary loop. These keywords are all specified within the secondary loop, as multiple secondary loops may be on the same primary loop, and each secondary may have a different type of connection.

PRIMARY-LOOP

Takes the U-name that references the primary loop to which this secondary loop is attached. There is no default. The primary loop type is always the same as the secondary type.

PRIMARY-FLOW-PCT

The percentage of the secondary flow that transfers to the primary flow at the design conditions. This value is used in the sizing calculations to determine the primary loop flow required to satisfy a secondary loop. For primary/secondary loops that operate at the same temperature, this value should be 1.0. If a hot-water primary operates at a significantly higher temperature than an attached secondary, then the primary flow created by the secondary demand may be significantly less than the flow circulating within the secondary loop itself.

For example, assume that a secondary loop has a supply setpoint of 160F, and a return temperature of 120F. The primary loop operates at a supply temperature of 250F. The secondary loop design load is 1 million Btuh. The design secondary flow is:

$$\text{GPM2} = 1 \times 10^6 \text{Btu} / (1.0 \text{Btu/lb-F} * 8.34 \text{lb/gal} * 60 \text{min/hr} * (160-120\text{F})) = 50 \text{ gpm}$$

The primary flow required to meet the design secondary load is:

$$\text{GPM1} = 1 \times 10^6 \text{Btu} / (1.0 \text{Btu/lb-F} * 8.34 \text{lb/gal} * 60 \text{min/hr} * (250-120\text{F})) = 15.4 \text{ gpm}$$

Therefore, PRIMARY-FLOW-PCT = $15.4 / 50 * 100\% = 31\%$

The same logic applies to chilled-water primary/secondary loops. Note that this keyword is used only in the design calculations to size the pump of the primary loop. You must specify primary and secondary loop temperature setpoints consistent with this keyword's value for the hourly simulation to be correct. Note also that this keyword applies to secondary loops having their own circulation pumps. A secondary loop without a pump must operate at the same temperature as the primary.

PRIMARY-TRANSFER

Takes a code-word specifies the type of heat transfer between a secondary loop and its primary loop.

DIRECT Indicates that the primary fluid flows directly into the secondary loop; the fluids intermix. In this mode, both loops must have the same fluid characteristics. If you enter different fluid properties for the primary and secondary loops, the program will issue a warning and override the secondary specification with the primary. If the static pressure of the loops different, one of the loops must have a STATIC-HEAD defined.

HEAT-EXCHANGER (not implemented this version) Indicates that the secondary loop is coupled to the primary using a heat-exchanger. In this case, the fluids are kept separate and may have different characteristics. Note that, when a heat-exchanger is specified, the secondary loop must have its own pump. If a secondary pump is not specified, then the program will issue a caution and specify the pump.

PRIMARY-HX-DT

(not implemented this version) When PRIMARY-TRANSFER = HEAT-EXCHANGER, this is the difference between the primary loop temperature entering the heat-exchanger, and the secondary loop temperature leaving the heat-exchanger. The program uses this value, together with the secondary design load and the primary/secondary flows, to compute the effective FcUA product of the heat-exchanger. This value is used in the hourly calculations to determine the temperature relationship between the primary and secondary loops. Normally, the secondary loop will control to its own hourly setpoint unless the heat-exchanger cannot provide fluid at the desired temperature; if not, the secondary supply temperature will float with the load.

PRIMARY-HX-HEAD

(not implemented this version) When PRIMARY-TRANSFER = HEAT-EXCHANGER, this is the head of the heat-exchanger. The head is assumed to be the same on both sides of the heat-exchanger, so that the head requirements of both the primary as well as the secondary pumps are increased by this value.

VALVE-TYPE-2ND

Accepts a code-word that specifies the type of valve that meters the primary fluid into the secondary loop or heat-exchanger. This valve is assumed to exist whenever the secondary loop has its own pump. If not, the secondary flow into the primary is always equal to the sum of the secondary coil loads.

TWO-WAY Specifies a two-way valve. The flow from the primary to the secondary is variable. The secondary loop flow may be either constant or variable, depending on the type of valves defined for the connected coils.

THREE-WAY Specifies a three-way valve. Any fluid not metered into the secondary is bypassed into the primary return, so that the primary flow is constant. The secondary loop flow may be either constant or variable, depending on the type of valves defined for the connected coils.

VALVE-HEAD-2ND

The head of the mixing valve that meters fluid between the primary and secondary loops. This valve is assumed to exist whenever the secondary loop has its own pump. If not, the secondary flow into the primary is always equal to the sum of the secondary coil loads. The head of this valve adds to the head of the primary pump only. Its head is additive to the PRIMARY-HX-HEAD, if a heat-exchanger exists.

Loop Availability

The following set of keywords describes how the loop operates over time. In the following discussions, a heating-type loop refers to a loop that delivers heating (HW, PIPE2, WLHP, DHW, LAKE/WELL). A cooling-type loop refers to a loop that delivers cooling or heat rejection (CHW, PIPE2, WLHP, LAKE/WELL).

LOOP-OPERATION

Takes a code-word that describes when or how the loop is activated. When activated, the loop pump, if any, runs and the specified primary equipment operates to deliver fluid at the specified temperature setpoints. When deactivated, the pump and all primary equipment are off. A deactivated loop will override the heating/cooling schedules of any secondary HVAC system coils that are attached. In other words, when a loop is active, an attached coil can draw energy from the loop according to the coil's heating/cooling schedules and temperature setpoint. However, when the loop is inactive, all attached coils are deactivated as well, regardless of their heating/cooling schedules.

STANDBY Causes the loop to be active whenever an attached system is running (fan on) and the system's heating/cooling schedule allows the coil to operate. Note that, in this mode, the system's coil may not actually be calling on the loop for the loop to be active.

DEMAND-ONLY Causes the loop to be active only when a coil or process load actually exists. This is the most energy-efficient mode of operation. For example, if an attached system is running and the system's cooling schedule allows for cooling, the CHW loop will not activate until there is actually a cooling load (the system could be using economizer cooling so that there is no cooling load that hour). DEMAND-ONLY operation is allowed for a WLHP, but is unrealistic. For a DHW loop, this option will cause a recirculation pump, if specified, to operate only when there is an end-use load.

SNAP A control mode where the loop operation snaps on or off according to a monitored temperature. SNAP has slightly different meanings depending on the type of loop:

For a heating-type loop, this keyword will cause the loop to activate when a specified temperature sensor is below the SNAP-T value. An outside-air lockout is another way of thinking of this control mode; however, the temperature causing the lockout may be either the outdoor air temperature, or a zone temperature. You specify the location of the temperature sensor using the SNAP-LOCN and SNAP-ZONE keywords.

Cooling-type loops are similar to heating-type loops, except that the loop will activate when the monitored temperature is above the SNAP-T value.

2-pipe loops will be in the heating mode below SNAP-T, and in the cooling mode above SNAP-T. In other words, the SNAP-T is the changeover temperature. Note, however, that a changeover temperature deadband can be specified using the HEATING-SCH and COOLING-SCH described under the next code-word.

WLHP loops will enable the heating equipment when below the SNAP-T, and the heat-rejection equipment above the SNAP-T. In practice, this is a dangerous control mode for WLHP's as the loop may go to an extreme temperature when either type of primary equipment is disabled.

SCHEDULED

Causes the loop to activate according to a schedule. Heating-type loops refer to the HEATING-SCH and cooling-type loops refer to the COOLING-SCH. PIPE2 and WLHP loops refer to both schedules, as they will have both heating and cooling equipment attached. As with SNAP control, SCHEDULED loop control is very dangerous for WLHP systems.

The schedules use the standard schedule values of 0 to indicate an OFF condition, and a 1 to indicate an ON condition. In addition, a value other than 0 or 1 is assumed to be an outdoor air lockout temperature. For a HEATING-SCH, an outdoor temperature below the schedule value will activate the loop. For a COOLING-SCH, an outdoor temperature above the schedule value will activate the loop. If desired, a zone temperature can be substituted for the outdoor temperature through the use of the SNAP-LOCN and SNAP-ZONE keywords. For all loops types except PIPE2 and WLHP, the schedule will activate the loop's pumps as well as the loop's primary equipment. For the PIPE2 loop, the HEATING-SCH will activate the heating equipment and loop pump and COOLING-SCH will activate the cooling equipment and loop pump. If outdoor temperatures are put into both schedules, there may be an outdoor temperature range where both the heating equipment, cooling equipment, and pump are off. If the schedules conflict, the HEATING-SCH will take precedence.

The WLHP loop operates in a similar fashion to the PIPE2 loop, except that the pump will continue to run regardless of the values of the heating and cooling schedules. To force off the pump (and all of the connected WLHP units), use the loop's PUMP-SCH. As with the SNAP mode, locking out either the boilers or the cooling towers can be a dangerous practice.

SUBHOURLY-DEMAND

specifies that the loop pump will cycle during the as required to meet loop flows less than design. This control mechanism applies to WLHP and CW loops only. If this control mechanism is specified for any other type loop, the program will reset the mechanism to DEMAND.

For WLHP and CW circulation loops only, the loop flow and pump are capable of cycling during the hour. This allows for better performance calculations when one or a few DX units are attached to a loop, and the loop pump cycles off whenever the unit(s) is not operating. In this situation, the program calculates the flow using the actual flow passed through the DX units when operating, adjusted by a diversity factor that takes into account the fact that the operation of various units on the loop do not necessarily coincide.

This mechanism works with either 2-way and/or 3-way valves on the DX units. For units with 3-way valves, flow will pass through the unit during the period the pump is active, regardless of whether the unit is active.

This control mechanism works only if the pump is directly attached to the loop; it will not work for pumps attached to boilers, towers, etc.

Only the pump cycles; the program does not extend this control strategy to boilers, towers, etc. The exception is that the temperature exiting a ground-loop heat-exchanger will be affected by the cycling period (for a given hourly load, as the load is compressed into a smaller fraction of the hour, the rate at which heat is extracted from or rejected to the ground increases, thereby affecting the temperature.)

A secondary loop can also simulate cycling, *however the diversity will not be passed on to the primary loop.*

HEATING-SCHEDULE

When LOOP-OPERATION = SCHEDULED, takes the U-name of a schedule with TYPE = ON/OFF/TEMP that enables the primary heating equipment attached to a loop. If not defined, the primary equipment is enabled whenever the loop is active. A schedule value of 0 disables the heating equipment, and a value of 1 enables it. A value other than 0 or 1 indicates that the outdoor air temperature is to be used to enable the heating equipment. The equipment will be enabled whenever the outdoor temperature is below the schedule value. If desired, a zone temperature can be substituted for the outdoor temperature using the SNAP-LOCN and SNAP-ZONE keywords.

COOLING-SCHEDULE

When LOOP-OPERATION = SCHEDULED, takes the U-name of a schedule with TYPE = ON/OFF/TEMP that enables the primary cooling or heat-rejection equipment attached to a loop. If not defined, the primary equipment is enabled whenever the loop is active. A value of 0 turns disables the equipment, and a value of 1 enables it. A value other than 0 or 1 indicates that the outdoor air temperature is to be used to enable the equipment. The equipment will be enabled whenever the outdoor air temperature is above the schedule value. If desired, a zone temperature can be substituted for the outdoor temperature through the use of the SNAP-LOCN and SNAP-ZONE keywords.

PUMP-SCHEDULE

Takes the U-name of a schedule with TYPE = ON/OFF that defines the operation of the pump. If not defined, the pump will run whenever the loop needs to be activated. A value of 0 disables the pump, and a value of 1 enables it. Usually, the PUMP-SCH should not be defined, except for DHW loops or WLHP loops. For all other loops, the pump will operate whenever the loop is active according to the LOOP-OPERATION criteria. For all loops other than DHW, the PUMP-SCH acts as an override to the LOOP-OPERATION to force the loop off during the specified times. The PUMP-SCH cannot force a loop to be active. For example, if the LOOP-OPERATION is DEMAND-ONLY, then the loop will be active whenever there is an active demand on the loop. The PUMP-SCH could be used to force the loop to be inactive during evenings or weekends even though the heating and cooling system schedules are specified to be on. As noted previously, the attached coils are forced inactive whenever the loop is inactive, although the system fans will continue to operate. WLHP units and water-cooled DX units will be forced off if their condenser loop is forced inactive.

For the DHW loop and LOOP-OPERATION = STANDBY (or undefined), the PUMP-SCH indicates when the recirculation pump, if any, is operating. A DHW loop delivers water to an end-use, where the water leaves the loop. Only a small portion of the total flow is circulated back to the water heater, and this is only so that the loop piping stays hot during periods of low demand. The PUMP-SCH allows the recirculation pump to be shut off during specified hours, even though there may still be process demands on the loop. The return leg will then cool, and thermal losses will be reduced or eliminated. Note that a DHW demand can exist even though the recirculation pump is off. In this case, the flow of the dhw demand will warm the supply side of the loop. The recirculation side will remain cool.

SNAP-T

When LOOP-OPERATION = SNAP, this is the temperature setpoint at which the snap will occur.

SNAP-LOCN

Takes a code-word that indicates the location of the snap-acting temperature sensor used in conjunction with the SNAP-T or the HEATING-SCH and COOLING-SCH. Allowed code-words are:

- OUTDOOR Indicates that the outdoor air temperature is used.
- ZONE Indicates that a zone temperature is used. You specify the zone using SNAP-ZONE.

SNAP-ZONE

When SNAP-LOCN = ZONE, takes the U-name of the zone containing the zone temperature. The default is the first conditioned zone found in the first system defined that is conditioned by this loop. Since this default is somewhat ambiguous, it is best to specify the zone.

Loop Temperature Control

The following set of keywords defines the loop temperature controller. The HEAT- keywords apply to heating-type loops and the COOL- keywords apply to cooling-type loops. PIPE2 and WLHP loops use both sets according to the mode in which they are operating.

LAKE/WELL loops do not utilize temperature control, as their temperature is strictly a function of the GROUND-LOOP-HX that supplies the ground-water. Note, however, that the DESIGN-COOL-T is used as the design condenser water temperature for any attached chillers, and the DESIGN-HEAT-T is used as the design “condenser” water temperature for any attached water-source heat-pump chillers.

When a process load exists, the program assumes that the load occurs at the loop’s design supply temperature, DESIGN-HEAT-T or DESIGN-COOL-T. For this reason, the program does not allow the loop’s supply temperature to be reset any hour that the process load is non-zero. The loop supply temperature can be reset during hours when the process load is zero.

The loop temperature control is applicable to primary loops, and to secondary loops having their own pump.

HEAT-SETPT-CTRL

Accepts a code-word that specifies the loop temperature control sequence. This keyword is valid only if the pumps have some means of capacity modulation, such as staging, two-speed, or variable-speed.

- FIXED The loop supply temperature is controlled to a fixed value specified by the HEAT-SETPT-T.
- OA-RESET The loop supply temperature is reset on outdoor air temperature according to HEAT-RESET-SCH.
- SCHEDULED The loop supply temperature is controlled to a schedule specified by HEAT-SETPT-SCH.
- LOAD-RESET The loop supply temperature is reset so that the valve of the worst-case coil is fully open. The maximum reset temperature for a heating-type loop is the MAX-RESET-T. Similarly, the minimum reset temperature for a cooling-type loop is MIN-RESET-T.

LOAD-RESET is applicable to any loop serving a hot water coil (HW, PIPE2). This mode maximizes the efficiency of the primary equipment and minimizes the loop's thermal losses, but at the expense of pumping energy in a variable-flow loop. You should refer to LOOP-FLOW-RESET for information on how to minimize the pumping penalties associated with this control scheme.

HEAT-SETPT-T

The heating setpoint when HEAT-SETPT-CTRL = FIXED. The default is the DESIGN-HEAT-T.

HEAT-RESET-SCH

Accepts a U-name of a reset schedule (of TYPE = RESET-TEMP) when HEAT-SETPT-CTRL = OA-RESET.

HEAT-SETPT-SCH

Accepts a U-name of a schedule of TYPE = TEMPERATURE when HEAT-SETPT-CTRL = SCHEDULED.

COOL-SETPT-CTRL

Code word specifies the loop temperature control sequence:

FIXED	specifies that the loop supply temperature is controlled to a fixed value, specified by the COOL-SETPT-T
OA-RESET	specifies that the loop supply temperature is reset on outdoor air according to the COOL-RESET-SCH.
SCHEDULED	specifies that the loop supply temperature is controlled to a schedule specified by the COOL-SETPT-SCH.
LOAD-RESET	specifies that the loop supply temperature is reset so that the valve of the worst-case coil is fully open. The minimum reset temperature for a cooling-type loop is MIN-RESET-T. LOAD-RESET is applicable to any loop serving a chilled-water coil (CHW, PIPE2). It is also applicable to a condenser-water loop; here this control mode will enable the cooling tower temperature to float with the load and wet-bulb temperature as described in the cooling tower sections.

Since a WLHP loop also uses a cooling tower, LOAD-RESET is applicable to the heat-rejection side of a WLHP loop. It does not apply, however, to the heating setpoint of a WLHP loop.

This mode maximizes the efficiency of the primary equipment and minimizes the loop's thermal losses (but at the expense of pumping energy in a variable-flow loop). Refer to LOOP-FLOW-RESET for information on how to minimize the pumping penalties associated with this control scheme.

COOL-SETPT-T

Accepts a numeric value which defines the cooling setpoint when COOL-SETPT-CTRL = FIXED. The default is the DESIGN-COOL-T.

For a CW loop having COOL-SETPT-CTRL = LOAD-RESET, this value acts as an upper limit on the floating temperature control. If the floating loop temperature exceeds this value, the fans will modulate as required to prevent the loop temperature from exceeding this value. Refer to the cooling tower sections for more information.

COOL-RESET-SCH

Accepts a U-name of a reset schedule (of TYPE = RESET-TEMP) when COOL-SETPT-CTRL = OA-RESET.

COOL-SETPT-SCH

Accepts a U-name of a schedule of TYPE = TEMPERATURE when COOL-SETPT-CTRL = SCHEDULED.

LOOP-SETPT-RNG

The throttling range of the loop temperature controller. To approximate proportional + integral control, set this value to a very small number ($\ll 1.0$). This keyword is ignored when the *-SETPT-CTRL = LOAD-RESET, as this control sequence assumes that a digital control system is controlling the HVAC systems.

LOOP-FLOW-RESET

The fraction of the design flow to which the flow in a variable-volume loop will be reduced prior to initiating a temperature reset. This keyword is used only when the HEAT-SETPT-CTRL or COOL-SETPT-CTRL = LOAD-RESET. In most loops, resetting the temperature as a function of load will increase the primary equipment efficiency and reduce the loop's thermal losses. However, in a variable-flow loop, the reset temperature will cause the coils to demand more flow than they normally would, and this will be at the expense of pump energy. In many cases, the increased pumping energy may more than offset any primary equipment savings. Specifying the LOOP-FLOW-RESET to a value less than 1.0 will cause the reset algorithm to attempt to drop the flow in the worst-case coil to the fraction specified prior to adjusting the loop supply temperature. This approach allows pump energy to be saved concurrently with the temperature reset. You must determine the best value in a trial-and-error fashion. A reasonable first try would be a value around 0.7 (the default).

MAX-RESET-T

When COOL-SETPT-CTRL = LOAD-RESET, places an upper limit on the CHW or PIPE2 supply temperature.

MIN-RESET-T

When HEAT-SETPT-CTRL = LOAD-RESET, places a lower limit on the HW or PIPE2 supply temperature. When COOL-SETPT-CTRL = LOAD-RESET in a CW loop, this keyword is the lower limit on the CW supply temperature.

MAX-ALARM-T

For WLHP loops, when the supply temperature exceeds this value, an alarm is triggered and the WLHP units are shut down.

MIN-ALARM-T

For WLHP loops, when the supply temperature falls below this value, an alarm is triggered and the WLHP units are shut down.

RESTART-AIR-T

For WLHP loops, specifying this keyword causes the loop to restart and run to provide freeze protection for a fluid cooler. When shut down, the loop will restart whenever the outdoor dry-bulb temperature drops below this value. You should refer to the section on fluid coolers for more information on using this keyword and the following RESTART-SETPT-T.

RESTART-SETPT-T

When RESTART-AIR-T causes a WLHP loop to restart, this keyword specifies the heating setpoint of the loop when operating in this mode. If the loop is already operating, then this keyword is ignored. You should refer to the section on fluid coolers for more information on using this keyword and the above RESTART-AIR-T.

Loop Circulation Pumps

The following set of keywords defines the operation of the loop's circulation pumps, if any, and the pumps' differential head pressure controller, if any. This controller is located somewhere on the loop, and measures the difference between the head on the supply side of the loop, and the head on the return side. As the differential head varies from its setpoint, this controller will stage pumps, vary their speed, etc. These keywords are relevant only when the loop is variable-flow, and the pumps have a capacity control mechanism other than "riding the curve". This controller applies to primary loops, and to secondary loops having their own pumps.

All loops must have a pump, however the pump does not always have to be attached directly to the loop. The following are also acceptable configurations:

CHW, HW, and PIPE2 loops may have pumps attached directly to the loop, and/or attached to each primary equipment unit that supplies the loop. For example, if a chilled-water loop has two chillers, the loop does not have a pump, but each chiller has a pump attached to its evaporator (CHILLER:CHW-PUMP), then the evaporator pumps will be sized and operate to overcome the head of the evaporator, loop, and coils. If in addition to the evaporator pumps, the loop also has a pump, then the loop pump will be sized and operated to overcome the head of the loop and coils, and the evaporator pumps will be sized and operated to overcome the head of the evaporator only.

CW loops are similar to the above, except that the equipment pumps may be attached to the *condensers* of chillers. If the loop does not have a pump, then the condenser pumps will power the loop. This allows condenser pumps to be staged with chillers. However, this configuration does not work if other demanders are on the condenser-water loop, such as water-cooled DX HVAC systems, as those components do not model pumps. Pumps attached to cooling towers never power the loop.

WLHP loops must always have a pump directly attached to the loop.

Please refer to the *Topics Manual* for more information on pumping configurations.

LOOP-PUMP

Accepts a U-name of the PUMP attached to this loop. You should use this keyword to attach a pump directly to a loop.

HEAD-SETPT-CTRL

Takes a code-word that specifies the type of control sequence used for controlling the head setpoint of the loop circulation pumps.

FIXED The differential head pressure is controlled to a constant setpoint, specified as HEAD-SETPT. The location of the differential pressure sensor is HEAD-SENSOR-LOCN.

VALVE-RESET A fixed head setpoint is not used. Instead the pumps are controlled so that the system head is just enough to provide the required flow to the worst-case coil, with that coil's control valve fully open. In other words, this control sequence monitors the position of the control valves of all coils attached to this loop, and adjusts the head so that the worst-case coil valve is fully open. This minimizes the pump energy wasted through valve throttling. Normally, this control sequence will require a direct-digital control system.

HEAD-SENSOR-LOCN

When HEAD-SETPT-CTRL = FIXED, accepts a code-word that specifies the location of the differential head pressure sensor.

AT-COILS	The differential pressure sensor is located at the far end of the loop, near the takeoffs to the coils. This is the most energy-efficient location (although VALVE-RESET control is better still).
ENTERING-LOOP	The differential pressure sensor is at the beginning of the loop, but downstream of any primary equipment.
AT-PUMP	Indicates that the sensor is right at the pump, upstream of the primary equipment. This is the least energy-efficient location.

HEAD-SETPT

The differential head pressure setpoint when HEAD-SETPT-CTRL = FIXED. If you enter a value for the HEAD-SETPT, the program will compare this value to the default value. If your value is not at least as large as the default, a warning will be issued. The defaults depends on the value of HEAD-SENSOR-LOCN:

AT-COILS	the default is the maximum design head of any attached coil or attached secondary loop, plus half of the throttling range.
ENTERING-LOOP	the default is the maximum design head of any attached coil or attached secondary loop, plus the loop piping head and static head, plus half of the throttling range.
AT-PUMP	the default is the maximum design head of any attached coil or attached secondary loop, plus the loop piping head and static head, plus the primary equipment head, plus half of the throttling range.

HEAD-SETPT-RATIO

A safety factor that multiplies the default HEAD-SETPT when HEAD-SETPT-CTRL = FIXED. This keyword has no effect if you specify HEAD-SETPT.

HEAD-SETPT-RNG

The throttling range of the controller when HEAD-SETPT-CTRL = FIXED.

Loop Thermal Losses

The next set of keywords defines the thermal (conduction) losses of the circulation loop. If these keywords are not entered, the loop piping is assumed to be adiabatic, i.e., to have no losses. The loop losses may vary considerably depending on the length of the loop and the temperature difference between the loop and its environment. This discussion uses the term "thermal loss" rather than heat loss because cooling-type loops experience a heat gain rather than a heat loss. Thermal loss is, therefore, an undesirable heat transfer into or out of the loop.

SUPPLY-UA

The conductivity of the loop on the supply side. If not defined, and the SUPPLY-LOSS-DT is also not defined, then the loop will experience no loss. This value should include losses through the pipe insulation, as well as any bypass effects due to the pipe hangars, crushed insulation, etc. When the UA is specified, the program will calculate the losses on an hourly basis as a function of the pipe UA product, the actual supply temperature, the actual environmental temperature, and the actual flow through the loop.

SUPPLY-LOSS-DT

The difference between the entering loop temperature and the loop temperature at the attached coils and/or secondary loop takeoffs. This temperature difference is assumed to occur when the loop is at its design flow, the loop supply temperature is the LOOP-SETPT-T, and the loop's environment is at its design temperature.

This keyword is an alternative to specifying the LOOP-SUPPLY-UA. If both are input, this keyword is ignored. The value represents the average temperature difference due to losses of all fluid delivered. In actual systems, coils further from the central plant (on longer pipe runs) will normally experience larger losses than coils closer to the central plant. This effect is not explicitly modeled. The program uses this value to calculate a supply piping UA product at the design conditions. This UA is used to calculate the hourly losses as previously described. Through experimentation, you may find that the overall HVAC energy consumption is relatively sensitive to the loop losses. This may be especially true for a system with a large number of distributed coils, such as reheat systems. In these cases, it is essential that you input an accurate value for the pipe loss.

RETURN-UA

The conductivity of the loop on the return side. This value should include losses through the pipe insulation, as well as any bypass effects due to the pipe hangars, crushed insulation, etc. When the UA is specified, the program will calculate the losses on an hourly basis as a function of the pipe UA product, the actual supply temperature, the actual environmental temperature, and the actual flow through the loop.

RETURN-LOSS-DT

The same as LOOP-SUPPLY-DT, but for the return side of the loop. For the supply side, the program calculates the loop UA assuming that the temperature entering the pipe is at the LOOP-SETPT-T. On the return side, the program calculates the temperature entering the return loop as a function of the LOOP-SETPT-T, the loop load and flow, and the supply-side loop loss. For loops that can provide both heating and cooling, this keyword should have a different value depending on whether the piping UA product is to be calculated with LOSSES-BASED-ON = HEATING-MODE or COOLING-MODE.

LOOP-LOCN

Takes a code-word that specifies the location of the loop piping.

OUTDOORS	Loop piping is outdoors. The loss calculations use the hourly outdoor air temperature as the pipe's environmental temperature.
ZONE	Loop piping is located in a zone specified by LOOP-LOSS-ZONE. The loss calculations use the hourly zone temperature as the pipe's environmental temperature. The piping losses will influence the zone temperature as well.
TUNNEL	Loop piping is located in a tunnel. The loss calculations use the LOOP-TUNNEL-T or the hourly LOOP-TUNNEL-SCH.
UNDERGROUND	Loop piping is buried. The loss calculations use the monthly ground temperature from the weather file or as specified in the SITE-PARAMETERS command.

LOOP-LOSS-ZONE

When LOOP-LOCN = ZONE, takes the U-name of the zone containing the loop. The zone may be conditioned, unconditioned, or a plenum. There is no default. Note that the pipe thermal loss will show up as a heating or cooling load on the zone, and will influence the zone temperature.

LOOP-TUNNEL-T

The annual average tunnel temperature when LOOP-LOCN = TUNNEL.

LOOP-TUNNEL-SCH

When LOOP-LOCN = TUNNEL, takes the U-name of a schedule of TYPE = TEMPERATURE that defines the hourly tunnel temperature. When a schedule is defined, the LOOP-TUNNEL-T is ignored. Note, however, that the LOOP-TUNNEL-T is used in the design calculations.

LOSSES-BASED-ON

For loops that can do both heating and cooling (PIPE2 and WLHP), takes a code-word that specifies whether the design UA is to be calculated on the basis of the heating or cooling mode of operation. This keyword applies when you specify the losses using the SUPPLY-LOSS-DT and/or RETURN-LOSS-DT in lieu of the SUPPLY-UA.

COOLING-MODE	The design UA is to be calculated based on the COOLING-ENVIR-T and the SUPPLY-LOSS-DT, where the SUPPLY-LOSS-DT is assumed to be the temperature change of the pipe at the design cooling conditions.
HEATING-MODE	Specifies that the design UA value is to be calculated based on HEATING-ENVIR-T and SUPPLY-LOSS-DT, where SUPPLY-LOSS-DT is the temperature change of the pipe at the design heating conditions.

ASSIGN-LOSSES-TO

Accepts a code-word that specifies the end-use category in which the thermal losses should be included. The program reports energy usage by end-use category in reports PS-E, PS-F, BEPS and BEPU. The default is SPACE-HEAT/COOL for all loops except domestic hot water, which defaults to DOM-HOT-WATER.

SPACE-HEAT/COOL	The default for most loop types, specifies that the losses will be included in the heating end-use category whenever the loop is in the heating mode, and the cooling end-use category whenever the loop is in the cooling mode.
DOM-HOT-WATER	The default for the domestic hot water loops, specifies that the losses will be included in the domestic water heating category. Normally, you would specify this category only for domestic hot water heating loops.
MISC-EQUIP/PROCESS	Specifies that the losses will be included in the miscellaneous equipment end-use category. Normally, you would specify this category only if the predominant load on the loop is a process load.

Whether the UA is calculated for the heating or the cooling mode, you should specify reasonable values for both the HEATING-ENVIR-T and COOLING-ENVIR-T. This is because the program also uses these variables to calculate the actual magnitude of both heating and cooling losses at the design conditions, and includes these losses in the design loop loads when auto-sizing the primary plant equipment.

HEATING-ENVIR-T

The design temperature of the pipe's environment when the loop is in a heating mode. This keyword is used by all loop types that can provide heating or domestic hot water, including 2-pipe and water-loop heat pump loops. If not specified, the temperature used in the design loop calculations depends on LOOP-LOCN:

OUTDOORS	the default is the minimum annual outdoor temperature.
ZONE	the default is the DESIGN-HEAT-T of the LOOP-LOSS-ZONE.
TUNNEL	the default is LOOP-TUNNEL-T.
UNDERGROUND	the default is the minimum annual ground temperature.

For loops that can do both heating and cooling (PIPE2 and WLHP), if the HEATING-ENVIR-T is not specified, but the COOLING-ENVIR-T is specified, then the piping UA will be based on the cooling mode temperatures. If neither HEATING-ENVIR-T nor COOLING-ENVIR-T is specified, then the piping UA will be calculated using the default values for heating according to the LOOP-LOCN.

COOLING-ENVIR-T

The design temperature of the pipe's environment when the loop is in a cooling mode. This keyword is used by all cooling-type loops. If not specified, the temperature used in the design loop thermal loss calculation depends on LOOP-LOCN:

OUTDOORS	the default is the minimum annual outdoor temperature.
ZONE	the default is the DESIGN-HEAT-T of the LOOP-LOSS-ZONE.
TUNNEL	the default is LOOP-TUNNEL-T.
UNDERGROUND	the default is the minimum annual ground temperature.

For loops that can do both heating and cooling (PIPE2 and WLHP), if the HEATING-ENVIR-T is not specified, but the COOLING-ENVIR-T is specified, then the piping UA will be based on the cooling mode temperatures. If neither HEATING-ENVIR-T nor COOLING-ENVIR-T is specified, then the piping UA will be calculated using the default values for heating according to the LOOP-LOCN.

Process Load Attached to a Loop

The next set of keywords allows you to specify a process load attached directly to a loop.

When a process load exists, the program assumes that the load occurs at the loop's design supply temperature. For this reason, the program does not allow the loop's supply temperature to be reset any hour that the process load is non-zero. The loop supply temperature can be reset during hours when the process load is zero.

PROCESS-LOAD

For all loops other than DHW, specifies the process load attached directly to the loop. This entry should be the peak load. The hourly load is calculated using this value and PROCESS-SCH.

DHW loops do not use this keyword. Instead, they use the PROCESS-FLOW together with the DHW-INLET-T or DHW-INLET-T-SCH and the loop temperature setpoint to calculate the process load. This load is modified hourly by the PROCESS-SCH.

For most loop types, the sign of the process load is disregarded; the program will convert the load to the correct sign (negative for heating loads, positive for cooling or heat rejection). For example, when you enter a process load for a hot-water loop, and enter the value as a positive number, the load will be converted to a negative load internally. For WLHP loops, the sign of the load is important, as this type of loop may have either a positive process load (heat taken from the process load and added to the loop), or a negative load (heat taken from the loop and given to the process). PIPE2 loops may not have a process load assigned, as the loop must be able to change over from heating to cooling according to the changeover criteria.

PROCESS-FLOW

For all loops other than DHW, specifies the flow associated with the PROCESS-LOAD. If not specified, the peak flow is calculated as a function of the PROCESS-LOAD, the PROCESS-LOAD-DT, and the fluid characteristics. The PROCESS-LOAD must be specified for this keyword to be used; otherwise it is ignored.

For DHW loops, the PROCESS-LOAD is not used; this keyword specifies the process flow, and the process load is calculated as a function of this flow, the supply temperature, and the make-up water temperature. This flow assumes no thermal losses in the piping; the actual load will be the sum of the load associated with this flow, plus the thermal losses.

PROCESS-SCH

Takes the U-name of a schedule with TYPE = MULTIPLIER that defines the usage profile for the process load. If not specified, the process load is constant all hours.

PROCESS-LOAD-DT

If PROCESS-FLOW is not defined, this is the change in temperature of the fluid serving the process load. The program uses this value to calculate the design fluid flow for the process load. If not specified, the default is the LOOP-DESIGN-DT. The sign of the temperature change is irrelevant; the program will make sure the calculated flow is positive.

Loop Auxiliary Load

The next set of keywords allows you to define an auxiliary load. This load may be associated with controls, heat tracing on pipes, etc. The auxiliary load consumes electricity, but does not appear as a load on the loop.

LOOP-AUX-KW

The auxiliary electrical load associated with this loop. The value entered should be the maximum (design) value. Hourly values are adjusted by the LOOP-AUX-SCH. This electrical load may be associated with controls, heat tracing on a pipe, or similar uses. The load is assumed to disappear; it does not show up as a load on the pipe, nor as a load in the space in which the pipe is located.

LOOP-AUX-SCH

Takes the U-name of a schedule with TYPE = MULTIPLIER that adjusts the LOOP-AUX-KW on an hourly basis. If you do not input a schedule, the load is constant all hours.

LOOP-AUX-METER

Accepts a code-word that specifies the electrical meter to which the LOOP-AUX-LOAD is attached. The default is MASTER-METER: ELEC-AUX-METER.

CIRCULATION-LOOP and the EQUIP-CTRL Command

By default, a circulation-loop will automatically allocate its load to the attached primary equipment. Alternatively, you can explicitly control the staging of equipment via one or more EQUIP-CTRL sequences.

Each CIRCULATION-LOOP can directly reference an EQUIP-CTRL command, and its associated control sequences, without the need for linking the EQUIP-CTRL command through a LOAD-MANAGEMENT command. This is convenient when you want to override the default load allocation logic for that loop, but you have no need to ever switch control sequences for this loop on a time of day or building peak load basis. If you want to switch sequences to control building peak loads, then the EQUIP-CTRL commands must be linked through the LOAD-MANAGEMENT command. Alternatively, you can attach an EQUIP-CTRL sequence locally, and then override the sequence under certain conditions via the LOAD-MANAGEMENT command.

You can attach an EQUIP-CTRL command directly to the CIRCULATION-LOOP and additionally link EQUIP-CTRL commands to the same CIRCULATION-LOOP through the LOAD-MANAGEMENT command. In this case, the LOAD-MANAGEMENT takes precedence over the directly referenced EQUIP-CTRL commands; in other words, if the LOAD-MANAGEMENT command activates a EQUIP-CTRL for a loop, any local EQUIP-CTRL commands for that loop will be ignored for that hour.

HEAT-EQUIP-CTRL

Takes the U-name of an EQUIP-CTRL command that specifies the control of the primary heating equipment attached to this loop. If not defined, the program will select the combination of equipment whose capacity best matches the load on an hourly basis. An EQUIP-CTRL sequence specified here may be overridden by a different

EQUIP-CTRL sequence selected by a LOAD-MANAGEMENT instruction on either a time, temperature, or load basis. This keyword applies to heating-type loops only. A cooling-type loop uses the COOL-EQUIP-CTRL keyword. A PIPE2 or WLHP loop may have both HEAT-EQUIP-CTRL and COOL-EQUIP-CTRL specified.

COOL-EQUIP-CTRL

Takes the U-name of an EQUIP-CTRL command that specifies the control of the primary cooling equipment attached to this loop. If not defined, the program will select the combination of equipment whose capacity best matches the load on an hourly basis. An EQUIP-CTRL sequence specified here may be overridden by a different EQUIP-CTRL sequence selected by a LOAD-MANAGEMENT instruction on either a time, temperature, or load basis. This keyword applies to cooling-type loops only. A heating-type loop uses the HEAT-EQUIP-CTRL keyword. A PIPE2 or WLHP loop may have both HEAT-EQUIP-CTRL and COOL-EQUIP-CTRL specified.

For heating-only or cooling-only loops, only the appropriate keyword is legal. The equipment referenced by the EQUIP-CTRL must be attached to this loop, and for this reason the same EQUIP-CTRL sequence cannot be attached to more than one CIRCULATION-LOOP; doing so will cause an ERROR to be issued.

For dual-mode loops that can provide, on a mutually exclusive basis each hour, heating and cooling/heat rejection (2-pipe and WLHP), either or both keywords can be specified. If only one EQUIP-CTRL command is specified for these dual-mode loops, then the program will default the equipment operation when in the other mode. (As described under EQUIP-CTRL, heating and cooling equipment cannot be mixed in the same EQUIP-CTRL command).

Other Loop Keywords

DHW-INLET-T

For DHW loops, the inlet temperature of the water supply to the heaters. The default is the hourly value of DHW-INLET-T-SCH, if defined, or the monthly ground temperature if not.

DHW-INLET-T-SCH

For DHW loops, takes the U-name of a schedule of TYPE = TEMPERATURE that gives the inlet temperature of the water supply to the heaters. The default is the DHW-INLET-T, if defined, or the monthly ground temperature if not.

COST-DATA

Takes the U-name of a MATERIALS-COST command. This command allows you to define first costs, maintenance costs, etc. for the loop.

EQUIPMENT-REPORTS

Accepts code-words YES or NO. When report PS-H of the PLANT-REPORTS is enabled, a report will print for this component unless this keyword is set to NO.

CURVE-FIT

Specifies the coefficients of a performance curve, or specifies a set of data points that the program will fit to determine the coefficients of a curve. The curve can then be assigned to a particular piece of HVAC equipment by referencing the U-name of the curve. This command should be used only if you find that the default curve is inappropriate. If CURVE-FIT is used with DIAGNOSTIC=COMMENTS, an output listing of the curve coefficients, input or calculated, will be printed.

TYPE

Takes a code-word that specifies the form of the curve.

LINEAR

The curve is linear in a single independent variable. It has the form

$$f(r) = c1 + c2*r,$$

where c1 and c2 are the coefficients and r is a dimensionless variable.

BI-LINEAR

The curve is bi-linear in 2 independent variables. It has the form

$$f(r1,r2) = c1 + c2*r1 + c4*r2,$$

where c1, c2, and c4 are coefficients and r1 and r2 are dimensionless variables.

Note that a bi-linear curve is treated by the program as if it were bi-quadratic with zero coefficients on the non-linear terms. Thus 4 coefficients should be input for a bi-linear curve; the 3rd coefficient c3 is ignored.

QUADRATIC

The curve is quadratic in one independent variable. It has the form

$$f(r1) = c1 + c2*r1 + c3*r1^2,$$

where c1, c2, and c3 are coefficients and r1 is a dimensionless variable.

BI-QUADRATIC

The curve is bi-quadratic in 2 independent variables. It has the form

$$f(r1,r2) = c1 + c2*r1 + c3*r1^2 + c4*r2 + c5*r2^2 + c6*r1*r2,$$

where c1, c2, c3, c4, c5, and c6 are coefficients and r1 and r2 are dimensionless variables.

CUBIC

The curve is cubic in one independent variable. It has the form

$$f(r1) = c1 + c2*r1 + c3*r1^2 + c4*r1^3,$$

where c1, c2, c3, and c4 are coefficients and r1 is a dimensionless variable.

BI-LINEAR-T

The curve is bi-linear in 2 independent variables. It has the form

$$f(T1,T2) = c1 + c2*T1 + c4*T2,$$

where c1, c2, and c4 are coefficients and T1 and T2 are variables with units of temperature.

QUADRATIC-T

The curve is quadratic in one independent variable. It has the form

$$f(T1) = c1 + c2*T1 + c3*T1^2,$$

where c1, c2, and c3 are coefficients and T1 is a variable with units of temperature.

BI-QUADRATIC-T The curve is bi-quadratic in 2 independent variables. It has the form

$$f(T1,T2) = c1 + c2*T1 + c3*T1^2 + c4*T2 + c5*T2^2 + c6*T1*T2,$$

where c1, c2, c3, c4, c5, and c6 are coefficients and T1 and T2 are variables with units of temperature.

BI-QUADRATIC-DT&T The curve is bi-quadratic in 2 independent variables. It has the form

$$f(dT1,T2) = c1 + c2*dT1 + c3*dT1^2 + c4*T2 + c5*T2^2 + c6*dT1*T2,$$

where c1, c2, c3, c4, c5, and c6 are coefficients and dT1 and T2 are variables with units of temperature difference and temperature, respectively.

BI-QUADRATIC-RATIO&T The curve is bi-quadratic in 2 independent variables. It has the form

$$f(r1,T1) = c1 + c2*r1 + c3*r1^2 + c4*T1 + c5*T1^2 + c6*r1*T1,$$

where c1, c2, c3, c4, c5, and c6 are coefficients. R1 is a dimensionless variable. T1 is a variable with units of temperature.

CUBIC-T The curve is cubic in one independent variable. It has the form

$$f(T1) = c1 + c2*T1 + c3*T1^2 + c4*T1^3,$$

where c1, c2, c3, and c4 are coefficients and T1 is a variable with units of temperature.

BI-QUADRATIC-T&RATIO The curve is bi-quadratic in 2 independent variables. It has the form

$$f(T1,r1) = c1 + c2*T1 + c3*T1^2 + c4*r1 + c5*r1^2 + c6*T1*r1,$$

where c1, c2, c3, c4, c5, and c6 are coefficients. T1 is a variable with units of temperature and r1 is a dimensionless variable.

QUADRATIC-DT The curve is quadratic in one independent variable. It has the form

$$f(DT1) = c1 + c2*DT1 + c3*DT1^2,$$

where c1, c2, and c3 are coefficients and DT1 is a variable with units of temperature difference.

CUBIC-DT The curve is cubic in one independent variable. It has the form

$$f(dT1) = c1 + c2*dT1 + c3*dT1^2 + c4*dT1^3,$$

where c1, c2, c3, and c4 are coefficients and dT1 is a variable with units of temperature difference.

BI-QUADRATIC-RATIO&dT The curve is bi-quadratic in 2 independent variables. It has the form

$$f(r1,dT) = c1 + c2*r1 + c3*r1^2 + c4*dT + c5*dT^2 + c6*r1*dT,$$

where c1, c2, c3, c4, c5, and c6 are coefficients. R1 is a dimensionless variable. dT is a variable with units of delta temperature.

INPUT-TYPE

Denotes whether the curve will be specified by coefficients or by data.

COEFFICIENTS The curve will be specified by inputting coefficients. The **COEFFICIENTS** keyword, as described below, should be used.

DATA The curve will be specified by inputting data. The keywords **INDEPENDENT** and **DEPENDENT** (for 1 independent variable) or **INDEPENDENT-1**, **INDEPENDENT-2**, and **DEPENDENT** (for 2 independent variables) should be used.

OUTPUT-MIN

The lower limit of the value of the curve. When the curve is evaluated in the simulation, if the result is less than **OUTPUT-MIN**, it is set to **OUTPUT-MIN**.

OUTPUT-MAX

The upper limit of the value of the curve. When the curve is evaluated in the simulation, if the result is greater than **OUTPUT-MAX**, it is set to **OUTPUT-MAX**.

INPUT-TYPE = COEFFICIENTS

COEFFICIENTS

Required when **INPUT-TYPE=COEFFICIENTS**. Takes a list of up to 6 coefficients - these correspond to c1 - c6 in the description of the keyword **TYPE** above. If too few coefficients are entered for a given curve **TYPE**, an error message will be issued. If too many are entered, the extra values will be ignored.

INPUT-TYPE = DATA

Up to 20 data points can be input to define a curve (The program will fit a curve of the specified **TYPE** through the points, arriving at a set of coefficients). A data point consists of a value for the dependent variable and 1 or 2 values for the independent variable(s). The keyword **DEPENDENT** is used to specify the set of values for the dependent variable. If there is only one independent variable, the keyword **INDEPENDENT** is used to specify the values for the independent variable. If there are 2 independent variables, the keywords **INDEPENDENT-1** and **INDEPENDENT-2** are used to specify the values of the first and second independent variables respectively. The abbreviations and the units for **INDEPENDENT**, **INDEPENDENT-1**, and **INDEPENDENT-2** vary depending upon the curve **TYPE**.

DEPENDENT

A list of up to twenty values of the dependent variable. The minimum number of values required depends on the **TYPE** of the curve to be fit to the data. A **LINEAR** curve requires at least 2 points, a **QUADRATIC** at least 3, and so forth. If not enough values have been entered, an error message will be issued.

INDEPENDENT

Used for all curves having only one independent variable. A list of up to twenty values of the independent variable. The number of values should be the same as for DEPENDENT.

INDEPENDENT-1

Used for all curves having two independent variables. A list of up to twenty values of the first independent variable. The number of values should be the same as for DEPENDENT.

INDEPENDENT-2

Used for all curves having two independent variables. A list of up to twenty values of the second independent variable. The number of values should be the same as for DEPENDENT.

Example 1: defining a curve by inputting a set of data points.

A packaged system (PZS) has cooling performance significantly different from that used in the default model. The manufacturer lists the data shown in Table 43, for cooling capacity, at 2000 cfm design air flow rate, as a function of outside dry-bulb temperature and entering wet-bulb temperature.

Table 43 Cooling capacity (kBtu/hr) vs. temperature

Outside Dry-bulb	Entering Wet-bulb		
	72F	67F	62F
85F	69	65	60
95F	68	63 (ARI)	57
105F	65	60	53
115F	62	55	49

In this example the independent variables are the entering wet-bulb temperature and the outside dry-bulb temperature. Because there are two independent variables and they have units of temperature, we input a curve of TYPE BI-QUADRATIC-T using the given data points. The dependent variable is not the cooling capacity listed in the table but rather the cooling capacity divided by the cooling capacity at the ARI rating point (95 F outside dry-bulb and 67 F entering wet-bulb). In other words, the capacities should be normalized to the ARI rating point, as shown in Table 44

Table 44 Normalized capacity vs. temperature

Outside Dry-bulb	Entering Wet-bulb		
	72F	67F	62F
85F	1.095	1.032	0.952
95F	1.079	1.0 (ARI)	0.905
105F	1.032	0.952	0.841
115F	0.984	0.873	0.778

The CURVE-FIT input will look like the following:

```

CAP-CURVE-1 = CURVE-FIT
  TYPE           = BI-QUADRATIC-T
  INPUT-TYPE     = DATA
  DEPENDENT      = (1.000,1.079,0.905,1.032,0.952,0.841,
                    0.984,0.873,0.778,1.095,1.032,0.952) ..
  IN-TEMP1       = ( 67, 72, 62, 72, 67, 62,
                    72, 67, 62, 72, 67, 62) ..
  IN-TEMP2       = ( 95, 95, 95, 105, 105, 105,
                    115, 115, 115, 85, 85, 85) ..

```

Example 2: Defining a curve by inputting coefficients

We want a furnace to have a constant efficiency as a function of part load. To do this we must replace the default FURNACE-HIR-FPLR with a curve that will give a constant efficiency. The curve TYPE is QUADRATIC in the part load ratio (PLR). PLR correction curves are always multiplied by the unit capacity, not the load, to obtain the energy (fuel or electricity) use. Thus the curve we want is: $0.0 + 1.0*PLR + 0.0*PLR*PLR$. The input will look like:

```

New-Furnace-HIR-fPLR = CURVE-FIT
  TYPE           = QUADRATIC
  INPUT-TYPE     = COEFFICIENTS
  COEFFICIENTS   = (0.0,1.0,0.0) ..

```

Then in the SYSTEM command we include:

```

FURNACE-HIR-FPLR = New-Furnace-HIR-fPLR

```

DW-HEATER

This command defines the operating parameters of a domestic water heater. Normally, the heater comes with a storage tank but you can also simulate instantaneous water heaters by setting the tank volume to a very small number. These heaters attach to a CIRCULATION-LOOP of TYPE=DHW and provide heated water for domestic purposes such as dish washing, showers, etc.

A U-name is mandatory for this command. .

Example Input:

```
DHW-1 = DW-HEATER
  TYPE           = GAS
  CAPACITY       = 0.03           $MBtu/hr
  DHW-LOOP       = DHW-LOOP-1
  TANK-VOLUME    = 100           $Gallons
  ..
```

TYPE

Takes a code-word that specifies the type of water heater. Available types are:

GAS	A gas-fired water heater.
ELEC	An electric resistance water heater.
HEAT-PUMP	A heat pump water heater with electric resistance backup.

TANK-VOLUME

The volume of the heater's storage tank. If not specified, the storage volume will default to the hourly capacity of the burner, immersion heater, or heat pump providing heat to the tank, at the design loop supply and inlet (makeup) temperature. This value will be rounded up to the nearest commonly available size (30, 40, 50, 75, 100, 150 gal, etc.)

CAPACITY

The heating capacity of the burner, immersion heater, or heat pump used to meet the DHW load and charge the tank. If you do not specify this keyword, the capacity will default to the design loop load, adjusted by the CAPACITY-RATIO. If no CAPACITY-RATIO is input, then the capacity will default to the loop capacity, divided by the number of DW-HEATERS attached to the loop.

CAPACITY-RATIO

When CAPACITY is not specified, this is the fraction of the design loop capacity that this heater will be sized to meet. There is no default. If you are defining two heaters of identical size that should just meet the design loop load, then CAPACITY-RATIO should be set to 0.5 for each heater. If you want to include a 20%, then the CAPACITY-RATIO of each heater is 0.6. If you do not specify either the CAPACITY or the CAPACITY-RATIO, then the capacity will default to the loop capacity divided by the number of heaters attached to the loop.

CAPACITY-FT

Takes the U-name of a curve that modifies the heater's capacity as a function of the supply temperature and the heater's environmental temperature. There is no default curve for GAS and ELEC heaters, so if CAPACITY-FT is not specified for these types, their capacity will be constant for all temperature conditions. For HEAT-PUMP water heaters, the default is curve DW-HeatPump-Cap-fSupplyT&EDB.

Energy Consumption

The next set of keywords defines the energy consumption of the water heater. Not all keywords are used for every heater type. For example, an electric water heater does not consume any fuel and so does not have an HIR.

However, a fuel-fired heater may have electrical usage, such as for a draft fan, and the electrical consumption of this fan may vary with load. Consequently, the fuel-fired heaters may use both the EIR and HIR set of keywords

AQUASTAT-SETPT-T

The setpoint of the domestic hot water heater's internal aquastat. The effective supply temperature is the larger of this value and the setpoint of the attached DHW loop. Range is 55.0 to 350.0 F (12.8 to 176.6 C) and the default is the attached DHW loop's HEAT-SETPOINT-T.

ELEC-INPUT-RATIO

The ratio of electric input power to nominal heater capacity. The EIR is dimensionless, so the same units for input and capacity should be used when calculating it. Note that "capacity" for a water heater refers to the burner, element, or heat-pump capacity and excludes the storage capacity of the tank.

EIR-FT

Takes the U-name of a curve that modifies the electric consumption as a function of the supply temperature and the environmental temperature. There is no default curve for GAS and ELEC heaters, so if EIR-FT is not specified for these types, their EIR will be constant for all temperature conditions.

EIR-FPLR

Takes the U-name of a curve that gives the EIR as a function of the heater part load ratio. If not specified, a default curve from the library will be used for electric and heat-pump water heaters. This curve must be normalized to 1.0 at full load.

HEAT-INPUT-RATIO

For GAS heaters only, this is the ratio of fuel heat input to heater capacity at full load (i.e., at the rated conditions). This is a dimensionless ratio, so you must convert heat input and heating capacity to the same units before dividing. Note that "capacity" for a water heater refers to the burner, element, or heat-pump capacity and excludes the storage capacity of the tank.

HIR-FT

Takes the U-name of a curve that modifies the HIR as a function of the supply temperature and the environmental temperature. There is no default. If HIR-FT is not specified, the HIR will be constant for all temperature conditions. The LOCATION keyword, below, determines whether the environmental temperature is the outdoor air temperature or a zone temperature.

HIR-FPLR

For GAS heaters only, takes the U-name of a curve that modifies the HIR as a function of the heater part load ratio. This curve must be normalized to 1.0 at full load.

TANK-UA

The overall heat loss coefficient (UA) of the heater. The heat loss is calculated as this value times the temperature difference between the water in the heater and the environmental temperature. TANK-UA should include conductive losses through the tank skin, as well as steady-state losses during times the burner is not firing. The default is calculated as follows:

For GAS heaters, the default is TANK-VOLUME (in gallons) times 0.3 Btu/hr-gal-F or TANK-VOLUME (in liters) times 0.042 W/l-K.

For ELEC and HEAT-PUMP heaters, the default is TANK-VOLUME (in gallons) times by 0.1 Btu/hr-gal-F or TANK-VOLUME (in liters) times 0.042 W/l-K. This is 1/3 the default loss of a gas heater.

LOCATION

Takes a code-word that specifies the location of the heater:

OUTDOOR	The heater is located outdoors or possibly in an unconditioned space, such as a garage, that has an average temperature close to the outdoor temperature.
ZONE	The heater is located in the zone specified by ZONE-NAME, below. <i>(Partially implemented; the program will use the zone temperature when calculating the tank losses or the performance of a HEAT-PUMP water heater, however these interactions do not have any effect on the zone temperature. For heat-pump water heaters, this can result in serious errors.)</i>

ZONE-NAME

Takes the U-name of the zone containing the heater when LOCATION = ZONE. You must specify the zone; if not, LOCATION will default to OUTDOOR. *(Partially implemented; the program will use the zone temperature when calculating the tank losses or the performance of a HEAT-PUMP water heater, however these interactions do not have any effect on the zone temperature. For heat-pump water heaters, this can result in serious errors.)*

AUX-KW

The auxiliary electrical consumption, such as for an internal pump that you do not wish to model explicitly, a draft fan, and/or controls.

AUX-MODE

Takes a code-word that specifies when the AUX-KW is consumed:

ALWAYS	Auxiliary power is consumed all hours.
WHEN-ON	Auxiliary power is consumed only during the hours the heater is operating.
WHEN-OFF	Auxiliary power is consumed only during the hours the heater is off.
SCHEDULED	Auxiliary power consumption is scheduled according to AUX-SCH.

AUX-SCHEDULE

When AUX-MODE = SCHEDULED, takes the U-name of a schedule of TYPE = MULTIPLIER that varies the AUX-KW on an hourly basis.

AUX-METER

Takes the U-name of a meter that supplies the auxiliary energy. This keyword defaults to the same meter as the heater's ELEC-METER.

ELEC-METER

Takes the U-name of the ELEC-METER to which the electricity consumption of the heater is assigned. Default is the MASTER-METER: DHW-ELEC-METER.

FUEL-METER

Takes the U-name of the FUEL-METER to which the fuel consumption of the heater is assigned. Default is the MASTER-METER: DHW-FUEL-METER.

Attachment to DHW Loop

DHW-LOOP

Takes the U-name of the primary DHW loop to which this heater is attached.

DHW-PUMP

Takes the U-name of a PUMP directly attached to the heater. Usually, if a domestic water loop has a pump, it will be a very small pump sized to circulate a small amount of water sufficient to offset the loop losses. This pump is located on the return leg of the loop (it does not pump the main supply flow, only the smaller recirculation flow). This type of pump should normally be specified within the CIRCULATION-LOOP command. If the heater has a pump that provides internal circulation, then this pump should be specified here. This pump would be in addition to the loop pump and would act to circulate water within the heater and not the loop. Also, if the loop has multiple heaters attached and each heater has its own loop recirculation pump (very unusual), then this pump should be specified here and no pump should be attached within the CIRCULATION-LOOP command. This pump will then act to circulate water within the heater and through the loop.

DHW-HEAD

The head loss through the heater at design flow. The default assumes that the relevant flow is for pumping the recirculated flow, not the supply flow (the program assumes that the pressure in the water main moves the supply flow).

DHW-STATIC-HEAD

The static head of the heater (non-varying with flow).

DW-MIN-FLOW

The minimum allowable fraction of the design recirculation flow for the pump.

DW-MAX-FLOW

The ratio of the maximum allowable supply flow to the design supply flow. The program will try to use more heaters if the flow is greater than this value.

HEAT-PUMP Water Heater

HP-SUPP-CAPACITY

For the HEAT-PUMP water heater only, this is the capacity of the backup immersion heater. The default is CAPACITY.

MAX-HP-TANK-T

For the HEAT-PUMP water heater only, this is the maximum water temperature that the heat pump can provide. Any additional boost to the supply temperature will be provided by the backup immersion heaters. For example, assume that a heater must provide 140F (60C) water to the DHW loop, the makeup water (inlet) temperature is 50F (10C) and the MAX-HP-TANK-T is 100F (37.8C). The heat pump will raise the temperature of the water entering the heater from 50F to 100F (10C to 37.8C) and the immersion heater will provide the final boost from 100F to 140F (37.8C to 60C).

Heat Recovery from Superheat

The next keyword defines the size of the tank-mounted heat-exchanger that recovers heat from the superheat of a direct-expansion air conditioning unit.

MAX-HTREC-RATE

The maximum hourly rate at which heat can be recovered. The default is no maximum limit. Heat will be recovered at this rate or the amount of superheat available, whichever is smaller, until the tank is heated to its CIRCULATION-LOOP setpoint temperature. This heater is referenced via the SYSTEM component from which desuperheat will be accomplished.

Energy for domestic water heating can also be recovered from the condensers of CHILLERS or the cooling jacket or exhaust of ELEC-GENERATORS. Unlike DX superheat recovery, this heat does not go directly into a water heater's storage tank; instead it is recovered on the makeup/return side of a domestic hot water CIRCULATION-LOOP and preheats the water entering the attached water heaters. Because the heat is recovered to the loop, no heat can be recovered during hours there is no loop flow. As a result, during times there is no loop flow, the burner in a DW-HEATER will have to operate to recharge the tank and/or offset thermal losses even though there may be waste heat available from the heat recovery devices.

For chiller heat recovery, refer to the HTREC keywords in the CHILLER component. For generators, refer to the HTREC keywords in the ELEC-GENERATOR component.

Space Heating from a Domestic Water Heater

Usually, hot water coils used for space heating are attached to a CIRCULATION-LOOP of TYPE = HW or PIPE2. There are some systems, however, that use the heat from a domestic water heater to provide space heating. These systems are typically in homes or apartments in climates requiring relatively little heating. To simulate this type of system, specify HEAT-SOURCE, ZONE-HEAT-SOURCE, PREHEAT-SOURCE, and/or BASEBOARD-SOURCE in the SYSTEM command to be of type DHW-LOOP. Then attach the coil to a domestic water loop using the SYSTEM's DHW-LOOP keyword or the ZONE's DHW-LOOP keyword (for a zonal coil). The program will take into account the required coil capacity when sizing the loop and auto-size the domestic water heaters attached to the loop. You should review the sizing parameters to make sure they are reasonable. Also, you should make sure that the heating coils entering water temperature is at least 10F (5.6K) warmer than the leaving air temperature, otherwise the program will not be able to size the coil correctly. Domestic water loops without any heating coils or recirculation do not need to be pumped; the program assumes the water main pressure is sufficient. The addition of heating coils to the loop requires the loop to be pumped. For DHW loops, this pump is located on the return side of the loop; it does not pump water that is used for dish washing or other domestic water uses, only water that returns to the water heaters. The pump is attached within the CIRCULATION-LOOP component, or alternatively, to each of the water heaters attached to the loop.

Miscellaneous**COST-DATA**

Takes the U-name of a MATERIALS-COST command, which allows you to define first costs, maintenance costs, etc. for this heater.

EQUIPMENT-REPORTS

Accepts the code-words YES or NO; the default is YES. When report PS-H of the PLANT-REPORTS is enabled, a report will print for this component unless the code-word is set to NO.

ELEC-GENERATOR

ELEC-GENERATOR defines all of the operating parameters of an electric generator. As with other plant components (boilers, chillers, etc.), each generator is specified separately, and has its own performance characteristics. In addition, generators may be stored in the library.

The generator is controlled with keywords in the ELEC-METER, EQUIP-CTRL, LOAD-MANAGEMENT, and CIRCULATION-LOOP commands. The ELEC-METER command contains keywords that control the operation of a generator and is analogous to a CIRCULATION-LOOP controlling the operation of a boiler. Depending on the specifications in these commands, the generator may be either off, tracking an electric load, tracking a thermal load, tracking the greater or lesser of an electric or thermal load, or may be running at maximum output.

The generator has distinctly different personalities, depending on its control mode. When tracking an electric load, the generator output is controlled by its ELEC-METER, and as a by-product produces waste heat that may be recovered to a heating CIRCULATION-LOOP and/or rejected to a heat rejection CIRCULATION-LOOP. When tracking a thermal load, the generator behaves like a boiler, is controlled by its CIRCULATION-LOOP, and as a "by-product" produces "waste" electricity that may be "recovered" to its ELEC-METER, and/or "rejected" to an electric utility via its SURPLUS-METER. The generator may switch control modes on an hourly basis.

U-name is required. This U-name will be used in the heading of the generator report to identify the generator.

TYPE

Accepts a code-word that specifies the type of generator. Available types are:

- ENGINE-GENERATOR specifies an engine-driven generator. The program does not distinguish between types of engines, but diesels may perform differently than natural-gas engines, etc. Therefore, you should confirm that the default performance data is representative of your engine.
- GAS-TURBINE-GENERATOR specifies a gas-turbine generator.
- STEAM-TURBINE-GENERATOR. specifies a steam-turbine generator.
- PV-ARRAY specifies a direct-current to alternating-current inverter, supplied with DC power via one or more PV-MODULEs. See the section describing this component for more information.

Note, for steam turbines, the program does not currently model steam loops. Instead, you attach the generator to a hot-water loop. The efficiency of the boiler should take into account the losses associated with de-aerators, blow down, etc.

CAPACITY

Accepts the capacity of the generator in kW. This is a mandatory entry, as the program does not size electrical loads.

CAPACITY-FT

Accepts the U-NAME of a curve that modifies the generator capacity as a function of the outdoor temperature.

MIN-RATIO

Accepts a numeric entry that specifies the ratio of the minimum possible output to the hourly operating capacity.

MAX-RATIO

The maximum fraction of rated load the generator is allowed to handle. If the generator is allowed to overload, MAX-RATIO may be greater than 1.0.

START-UP-TIME

Accepts a numeric entry specifying the equivalent amount of full-load run time necessary to bring the equipment up to operating conditions. If a generator is to be used in the current hour, but did not operate the previous hour, then a start-up load is presumed to exist. The equivalent full-load run time added to the current hour's load varies according to how many hours the generator has been shut down:

1 hour:	50% of this value
2 hours	80% of this value
3 or more hours	100% of this value

Energy Consumption of the Generator**HEAT-INPUT-RATIO**

Accepts a numeric entry specifying the ratio of design fuel consumption to design electrical output, when both are in the same units.

This keyword applies only to fuel consuming generators, i.e., engine-generators and gas-turbine generators. It does not apply to steam-turbine generators (see the section describing steam-turbine keywords for more information).

Note that this entry is in terms of the higher heating value of the fuel. Most generator data is tabulated in terms of the lower heating value, which allows fuel consumption to be relatively independent of the fuel type. The program does not correct for fuel type. Therefore, if you are specifying a generator that can use more than one fuel type, you must calculate fuel consumption rate for the actual fuel to be used, adjust it to the higher heating value, and base the HEAT-INPUT-RATIO on this value.

HIR-FT

Accepts the U-name of a curve that modifies the fuel consumption as a function of the outdoor temperature. There is no default; the HEAT-INPUT-RATIO is assumed constant for all temperature conditions if this keyword is not specified.

HIR-FPLR

Accepts the U-name of a curve that modifies the fuel consumption as a function of the part load ratio, where the part load ratio is defined as the ratio of the hourly load divided by the hourly operating capacity. For steam-turbine generators, this curve has a similar meaning, but modifies the steam consumption as a function of part load.

AUX-KW

Accepts a numeric entry that specifies any auxiliary electrical load associated with this generator. The default is 0. The value entered should be the maximum (design) value. Hourly values are adjusted by the AUX-SCH. This electrical load may be associated with controls, a heat-recovery pump, a heat-rejection radiator, or similar uses. The heat associated with the AUX-KW is presumed to disappear; it does not show up as a load on any component, nor as a load in the space in which the generator is located.

AUX-MODE

Accepts a code-word specifying when the AUX-KW is consumed.

ALWAYS	the default, indicates that the auxiliary power is consumed all hours.
--------	--

WHEN-ON Indicates that auxiliary power is consumed only during the hours the generator is operating.

WHEN-OFF indicates that auxiliary power is consumed only during the hours the generator is off.

SCHEDULED indicates that the power consumption is scheduled.

AUX-SCHEDULE

Accepts the U-name of a schedule (TYPE=FRAC^{TION} or MULTIPLIER) that adjusts the AUX-KW on an hourly basis. If you do not input a schedule, then the load is constant all hours.

AUX-METER

Accepts a code-word that specifies the electrical meter to which the AUX-KW is attached. The default is the MASTER-METER:AUX-ELEC-METER.

ELEC-METER

Accepts a code-word specifying the electric meter the generator will supply. The electric meter must be of type UTILITY or ELECTRIC-SALE. A generator cannot be attached to a BUILDING or SUB-METER level meter.

When this meter is of type UTILITY, power produced by the generator will be consumed on-site to meet this meter's demands. Depending on the operating mode of the generator(s), it might be possible for the generator(s) to produce more power than is demanded by this meter. In this case, you should also specify a SURPLUS-METER so that the power can be sold; otherwise the surplus power will be lost.

When this meter is of type ELECTRIC-SALE, then all power produced by the generator will be sold; none will be consumed on-site.

SURPLUS-METER

Accepts a code-word specifying the electric meter through which surplus power generation will be sold. The meter specified here must be of type ELECTRIC-SALE. The generator uses this keyword only if the meter specified under ELEC-METER is of type UTILITY. In this case, the generator's output will first be used to satisfy the demands of the ELEC-METER, with any surplus sold through the SURPLUS-METER.

FUEL-METER

Accepts a code-word specifying the fuel meter that supplies an engine generator or gas-turbine generator. The program does not adjust the generator's performance on the basis of fuel type; you should refer to the HEAT-INPUT-RATIO keyword for a discussion of the higher vs. lower heating value of a fuel.

Exhaust Heat Recovery to a Hot-Water, WLHP, or DHW Loop

EXH-LOOP

Accepts the U-name of the HW, WLHP or DHW loop to which this generator will recover exhaust heat. The default is that no heat will be recovered.

EXH-RCVR

Accepts a numeric entry specifying the fraction of full load fuel consumption that is recoverable from the exhaust gases.

EXH-RCVR-FPLR

Accepts the U-name of a CURVE-FIT instruction that specifies the variation in full-load recoverable exhaust heat with part load ratio. This curve must be normalized to 1.0 at a part load ratio of 1.0. When specifying this curve you

should verify that your curve is coordinated with the HIR-FPLR curve. Otherwise, the program may get into an unreal situation where more heat is being recovered at low loads than is consumed in fuel.

Jacket Heat Recovery to a Hot-Water, WLHP, or DHW Loop

JAC-LOOP

Accepts the U-name of the HW, WLHP or DHW loop to which this generator will recover engine jacket heat. The default is that no heat will be recovered.

JAC-RCVR

Accepts a numeric entry specifying the fraction of full load fuel consumption that is recoverable from the engine-jacket gases. This value should be coordinated with the HEAT-INPUT-RATIO and the EXH-RCVR keywords to keep the simulation realistic.

JAC-RCVR-FPLR

Accepts the U-name of a CURVE-FIT instruction that specifies the variation in full-load recoverable engine-jacket heat with part load ratio. This curve must be normalized to 1.0 at a part load ratio of 1.0. When specifying this curve you should verify that your curve is coordinated with the HIR-FPLR curve. Otherwise, the program may get into an unreal situation where more heat is being recovered at low loads than is consumed in fuel.

JAC-SETPT-T

Specifies the temperature setpoint of the engine temperature control. When coupled to a condenser water loop, the program uses this value to calculate the required flow through the engine jacket.

RCVR-TRACK-LOOP

Accepts a code word specifying the basis for the thermal tracking modes. The tracking mode is controlled by the electric meter specified in the ELEC-METER keyword.

TRACK-EXH-LOOP	specifies that, when thermal tracking, the engine will track the EXH-LOOP load. If jacket heat is recovered to the same loop as the exhaust, then it will track according to both. If jacket heat is recovered to a separate loop, then the engine will actively track the exhaust loop thermal demand, and heat-recovery to the jacket loop will be passive.
TRACK-JAC-LOOP	specifies that, when thermal tracking, the engine will track the JAC-LOOP load. If jacket heat is recovered to the same loop as the exhaust, then it will track according to both. If jacket heat is recovered to a separate loop, then the engine will actively track the jacket loop thermal demand, and heat-recovery to the exhaust loop will be passive.
TRACK-BOTH-LOOPS	specifies that the engine will thermal track both the engine and the jacket loop. Normally the thermal load requiring the greater capacity will be selected on an hourly basis. However, if the ELEC-METER:COGEN-TRACK-MODE = TRACK-LESSER, then the load requiring the smaller capacity will be selected.

Heat Rejection to a CW or WLHP Loop

CW-LOOP

Accepts a code-word specifying the circulation loop to which waste heat will be rejected. The loop must be of type CW or WLHP. This is an optional keyword; if you do not specify a waste-heat loop, then the heat-rejection device is assumed to be integral to the generator, and the energy consumed to reject heat is assumed to be included in the

generator's performance characteristics. For an engine-generator, only jacket heat is rejected to this loop. The model assumes that surplus exhaust heat will be diverted around the heat-exchanger and rejected to the outdoors.

CW-DT

Accepts a numeric value specifying the temperature change through the fluid that accepts the waste heat. This value is used to calculate the design loop flow. The default is the CIRCULATION-LOOP:LOOP-DESIGN-DT.

CW-HEAD

Accepts a numeric value which specifies the pressure drop of the coolant through the engine jacket or heat-exchanger at the design flowrate. This value should include the friction losses of any control valves, trim, and any piping associated with the generator and not included in the pressure drop of the loop which serves this generator.

CW-FLOW-CTRL

Accepts a code-word specifying the type of flow through the engine jacket.

CONSTANT-FLOW the default, indicates that the jacket flow is independent of the heat rejection load. This is accomplished using a three-way valve.

VARIABLE-FLOW indicates that the jacket flow varies linearly with the load.

Steam-Turbine Generators

STEAM-LOOP

Accepts a U-name of a circulation-loop that provides steam to the turbine. Since the program does not currently simulate steam loops, this loop must be of type HW.

STEAM-ENT-PRES

Specifies the steam pressure (psig) entering the turbine. The program uses this value to calculate both the steam enthalpy as well as the maximum possible thermodynamic efficiency of the turbine.

STEAM-SUPER-T

Specifies the degrees of superheat above saturation of the steam entering the turbine. The program uses this value, together with the STEAM-ENT-PRES, to calculate the steam enthalpy.

STEAM-EXH-PRES

Specifies the steam pressure exiting the turbine. The program uses this value to calculate both the steam enthalpy (assuming saturated steam) as well as the maximum possible thermodynamic efficiency of the turbine.

STEAM-ENTH-FP&P

Accepts the U-name of a CURVE-FIT that calculates the theoretical steam consumption rate (lbs/kWh) of the turbine as a function of the STEAM-ENT-PRES and the STEAM-EXH-PRES.

This theoretical rate assumes an isentropic expansion (reversible, adiabatic) and corresponds to the maximum possible efficiency of the turbine for the given inlet and outlet pressures. The actual steam rate is adjusted by the MECH-EFF. For part load performance, the steam rate is further adjusted by the HIR-FPLR curve.

Because the steam turbine algorithm calculates energy consumption using this approach, the HEAT-INPUT-RATIO is not used.

STEAM-CONDENSATE

Specifies the fraction of steam entering the turbine that returns as condensate.

MECH-EFF

Specifies the mechanical efficiency of the steam turbine at full load. The overall efficiency of the turbine is the product of the MECH-EFF and the maximum theoretical efficiency as calculated using the STEAM-ENT-PRES, STEAM-SUPER-T, STEAM-EXH-PRES, and STEAM-ENTH-FP&P.

Photovoltaic Arrays and Inverters

A photovoltaic "generator" consists of one or more PV-MODULEs, and a direct-current to alternating-current inverter. This generator type is treated and controlled in a manner identical to other generators:

You may specify that power be consumed on-site only, that power is consumed on-site with the surplus sold, or that all power consumed on-site is bought from the utility at one rate, and all power generated by the array is sold at a different rate (buy/sell arrangement).

You may specify EQUIP-CTRL sequences to coordinate this "generator" with other generators. For example, consider a remote facility independent of the power grid that has 24-hour electrical loads. The facility has a photovoltaic array that typically meets its daytime needs, and an engine-generator that runs at night and on cloudy days. You will need to use an EQUIP-CTRL sequence to preferentially load the inverter when it has power available.

You may specify more than one photovoltaic ELEC-GENERATOR. For example, if a building has two surfaces covered with photovoltaic modules, and the surfaces face in different directions, then you should model these as two separate ELEC-GENERATORS, as their performance will be quite different.

Please refer to the general discussions of the available control strategies in the ELEC-METER and ELEC-GENERATOR commands. Note that, if you do not specify otherwise, the inverter will track the on-site electrical load, with no surplus generated or sold.

The inverter capacity (output kW) is always a mandatory entry. The number of inverters, as well as the number of series vs. parallel photovoltaic modules in the array may be computed in a variety of ways:

You may directly specify all values.

You may allow the series/parallel configuration of photovoltaic modules to default based on the inverter capacity, the number of inverters, and the maximum tracking voltage of the inverter. In this case, the number of modules in series is computed as the maximum tracking voltage of the inverter, divided by the maximum power point voltage of the module, rounded down. The number of modules in parallel is the total inverter capacity, divided by the product of the capacity/module and number of modules in series, rounded down.

You may allow the number of inverters and the series/parallel module configuration to default based on a reference to a BUILDING-SHADE or EXTERIOR-WALL component. In this case, the program calculates the total number of modules and array capacity based on the shading surface area vs. module area. The number of inverters required is equal to the array capacity divided by the capacity per inverter rounded up. The number of modules in series is the maximum tracking voltage of the inverter, divided by the maximum power point voltage of the module, rounded down. The number of modules in parallel is the total number of modules, divided by the number of modules in series.

Because of the complexity of the defaulting sequences, we recommend that you turn on the BDL comments feature (DIAGNOSTIC COMMENTS ..) prior to entering this command. This will allow you to review the default number of inverters, the number of series vs. parallel modules, and other defaults.

Table 45 summarizes the units for both inverters and PV-MODULES. Note that, for a PV-MODULE, most performance data other than physical dimensions are reported by the manufacturers only in metric units. For this reason, most of the module units are metric, even when the rest of the input is in English.

The Sandia Laboratory in Los Alamos, New Mexico, USA maintains a database of PV modules that may be downloaded from their website. For convenience, the variable names used in that database are included in DOE-2 as the abbreviations to corresponding keywords. Where these variables exist, the Sandia abbreviation is identified using the format (Sandia database: 'xxx')

CAPACITY

specifies the capacity per inverter. This is a mandatory entry

NUM-INVERTERS

specifies the number of inverters that operate in parallel. All inverters have the same capacity (in this component; other photovoltaic ELEC-GENERATORS may also exist, but connect to a different set of PV modules). The net generator capacity is the capacity per inverter, multiplied by the number of inverters. If a BUILDING-SHADE or EXTERIOR-WALL surface is referenced, the number of inverters will default to the capacity required by the referenced surface. Otherwise, this entry is mandatory.

ELEC-INPUT-RATIO

specifies the ratio of direct-current input power to alternating-current output power. This number is the inverse of the full-load efficiency, and as such is always greater than 1.0.

EIR-FPLR

accepts the U-name of a curve that modifies the nominal electric input ratio as a function of the hourly part load ratio. This use of this curve is identical to part-load curves documented elsewhere in this manual.

INVERTER-CTRL

when NUM-INVERTERS is greater than one, specifies the staging control mechanism as the load varies:

RUN-ALL	the default, specifies that all inverters are to run, even at very low loads.
RUN-NEEDED	specifies that the inverters are to be staged as the load varies. This mechanism is generally more efficient than running more inverters than is necessary.

MIN-OPER-VOLTS

specifies the minimum input voltage below which the inverter will shut down.

MIN-TRACK-VOLTS

specifies the minimum input tracking voltage at which the inverter can operate efficiently. Below this value, the inverter can still operate, however its efficiency will drop linearly as a function of the actual input voltage divided by the minimum tracking voltage.

MAX-TRACK-VOLTS

specifies the maximum input tracking voltage at which the inverter can operate efficiently. Any input voltage above this value will be limited to this value in the power conversion calculations.

MIN-RATIO

specifies the minimum allowable operating ratio, below which the inverter will shut down. In other words, if the inverter cannot output at least this fraction of its CAPACITY, then inverter will not operate.

MAX-RATIO

specifies the maximum allowable operating ratio. The inverter will limit its output to be less than or equal to the CAPACITY*MAX-RATIO.

PV-MODULE

accepts the U-name of the photovoltaic module that comprises the array. This is a mandatory entry.

MODULES-SERIES

specifies the number of photovoltaic modules wired in series. Wiring modules in series increases the direct current voltage, with no change in current.

The default is the inverter maximum tracking voltage divided by the module maximum power point voltage.

MODULES-PARALLEL

specifies the number of photovoltaic modules wired in parallel. Wiring modules in parallel increases the current, with no change in voltage.

The default is the inverter capacity multiplied by the number of inverters, divided by the module capacity at the maximum power point, divided again by the number of modules in series.

MOUNT-TYPE

accepts a code-word specifying the mounting configuration of the photovoltaic array. This is a mandatory entry.

RACK	specifies that the array is mounted on a rack that does not shade the building.
STANDOFF	specifies that the array is mounted very closely to another surface, but that the surface does not shade the building.
INSULATED-RACK	specifies that the array is mounted directly to another surface, or that the back of the array is insulated. The surface does not shade the building.
BUILDING-SHADE	specifies that the array is mounted on a rack that shades the building roof and/or other building surfaces. The program will require you to reference a previously defined shading surface, and the number of modules will default to a function of the area of this surface, modified by the ARRAY-FRACTION.
BUILDING-SURFACE	specifies that the array is directly mounted on an exterior wall or roof. The program will require you to reference a previously defined exterior wall or roof, and the number of modules will default to a function of the area of this surface, modified by the ARRAY-FRACTION.

BUILDING-SHADE

when MOUNT-TYPE = BUILDING-SHADE, accepts the U-name of a previously defined shading surface. The module orientation will default to the orientation of this surface, and the default number of modules will be a function of the area of this surface, modified by the ARRAY-FRACTION.

A building shade may be shaded by other surfaces, and the program will automatically generate a shading report for any building shade having an attached PV array. Note however, that the program ignores any shading effects when calculating the performance of the array. It is important that you review this report to determine shading will degrade the actual performance of the array.

EXTERIOR-WALL

when MOUNT-TYPE = BUILDING-SURFACE, accepts the U-name of a previously defined exterior wall or roof. The module orientation will default to the orientation of this surface, and the default number of modules will be a function of the area of this surface, modified by the ARRAY-FRACTION.

You should specify the characteristics of the wall (LAYERS, ABSORPTANCE, ROUGHNESS) taking the effect of the photocells and their glazing into account. For example, if the average efficiency of the photocells is 0.07, the ABSORPTANCE of the wall's CONSTRUCTION should be reduced by this amount.

An exterior-wall may be shaded by other surfaces, and the program will automatically generate a shading report for any wall having an attached PV array. Note however, that the program ignores any shading effects when calculating the performance of the array. It is important that you review this report to determine shading will degrade the actual performance of the array.

EXTERIOR-ROOF

when MOUNT-TYPE = BUILDING-SURFACE, accepts the U-name of a previously defined exterior wall or roof. This entry is an alternative to specifying the surface using EXTERIOR-WALL.

An exterior-roof may be shaded by other surfaces, and the program will automatically generate a shading report for any roof having an attached PV array. Note however, that the program ignores any shading effects when calculating the performance of the array. It is important that you review this report to determine shading will degrade the actual performance of the array.

ARRAY-FRACTION

when MOUNT-TYPE = BUILDING-SHADE or BUILDING-SURFACE, specifies the fraction of the surface that is covered by photovoltaic modules. The default is 1.0, meaning that the entire surface is covered with photovoltaic modules.

Note that the program defaults the number of photovoltaic modules in series according to the inverter's maximum tracking voltage divided by the module's maximum power point voltage, rounded down. The number in parallel is then defaulted to the total number that will fit on the surface, divided by the number in series, rounded down. For these reasons, the actual number of modules calculated may not completely cover the surface.

MOUNT-HEIGHT

specifies the average distance between the back of the array and the surface to which it is mounted. The default varies according to the MOUNT-TYPE.

The defaults for the WIND-COEF, OFFSET-T, and CELL-T-COEF all vary in accordance with this distance.

MOUNT-AZIMUTH

specifies the azimuth of the array rack, where 180° is due south, relative to the building coordinate system. If MOUNT-TYPE = BUILDING-SHADE or BUILDING-SURFACE, the azimuth defaults to the azimuth of the referenced surface, relative to the building coordinate system. Otherwise, the azimuth defaults to 180°.

MOUNT-TILT

specifies the tilt of the array rack, where 0° is horizontal (surface outward normal pointing straight up). If MOUNT-TYPE = BUILDING-SHADE or BUILDING-SURFACE, the tilt defaults to the tilt of the referenced surface. Otherwise, the tilt is a mandatory entry.

GND-REFLECTANCE

specifies the ground reflectance on the array rack. If MOUNT-TYPE = BUILDING-SHADE or BUILDING-SURFACE, the ground reflectance defaults to the ground reflectance of the referenced surface. Otherwise, the default is 0.20.

WIND-COEF-A

This keyword is given the value of the “a” coefficient or term used to modify the back-surface cell temperature in the Sandia equation:

$$T_m = E * \text{Exp}(A+B*WS) + T_{\text{amb}}$$

where

T_m = the back-surface cell temperature, °C

T_{amb} = Ambient air temperature, °C

E = plane-of-array solar irradiance on module, W/m²

WS = wind speed, m/sec

A = empirical coefficient determining upper temperature limit at low wind speeds

B = empirical coefficient determining the temperature drop with wind

The default varies according to the MOUNT-HEIGHT.

WIND-COEF-B

This keyword is given the value of the “b” coefficient or term used to modify the back-surface cell temperature in the Sandia equation:

$$T_m = E * \text{Exp}(A+B*WS) + T_{\text{amb}}$$

The default varies according to the MOUNT-HEIGHT. See WIND-COEF-A for more information.

WIND-COEF

replaced by WIND-COEF-A and WIND-COEF-B in August 2003.

OFFSET-T

replaced by WIND-COEF-A and WIND-COEF-B in August 2003.

CELL-T-COEF

replaced by WIND-COEF-A and WIND-COEF-B in August 2003.

ELEC-METER

accepts a code-word specifying the electric meter the generator will supply. The electric meter must be of type UTILITY or ELECTRIC-SALE. A generator cannot be attached to a BUILDING or SUB-METER level meter.

When this meter is of type ELECTRIC-SALE, then all power produced by the generator will be sold; none will be consumed on-site.

When this meter is of type UTILITY, power produced by the generator will be preferentially consumed on-site to meet this meter's demands. Depending on the operating mode of the generator(s), it might be possible for the generator(s) to produce more power than is demanded by this meter. During these times, the meter will attempt to "run backwards", if allowed to by the meter's associated UTILITY-RATE. In this case, the surplus energy will be sold back to the utility at the same energy rate at which energy is bought. Please refer to the UTILITY-RATE component for more information on running a meter backwards.

If you wish to preferentially consume the generator power on-site, and sell any surplus at a rate different than which power is bought, then this meter should be of type UTILITY, and you should also specify the SURPLUS-METER.

SURPLUS-METER

accepts a code-word specifying the electric meter through which surplus power generation will be sold. The meter specified here must be of type ELECTRIC-SALE. The generator uses this keyword only if the meter specified under ELEC-METER is of type UTILITY. In this case, the generator's output will first be used to satisfy the demands of the ELEC-METER, with any surplus sold through the SURPLUS-METER.

Table 45 PV Inverter and PV Module Units

Keyword	English Default	English	Metric	English to Metric
ELEC-GENERATOR				
MIN-OPER-VOLTS	none	Volts	Volts	-
MIN-TRACK-VOLTS	none	Volts	Volts	-
MAX-TRACK-VOLTS	none	Volts	Volts	-
ARRAY-FRACTION	1.0	fraction	fraction	-
MOUNT-HEIGHT	varies	feet	meters	0.3048
MOUNT-AZIMUTH	Surface Az or required	degrees	degrees	-
GND-REFLECTANCE	0.2	fraction	fraction	-
WIND-COEF-A	varies w/ mount height	(°C-m²)/W	(°C-m²)/W	-
WIND-COEF-B	varies w/ mount height	(°C-sec-m)/W	(°C-sec-m)/W	-
PV-MODULE				
HEIGHT	none	feet	meters	0.3048
WIDTH	none	feet	meters	0.3048
CELL-BACK-DT	2.	°C	°C	-
VOLTS-OPEN-CKT	none	Volts	Volts	-
VOLTS/T-OPEN-CKT	none	Volts/°C	Volts/°C	-
AMPS-SHORT-CKT	none	Amps	Amps	-
AMPS/T-SHORT-CKT	none	1/°C	1/°C	-
VOLTS-MAX-PWR	none	Volts	Volts	-
VOLTS/T-MAX-PWR	none	Volts/°C	Volts/°C	-
VOLTS/E-MAX-PWR	none	Volts/°C	Volts/°C	-
AMPS-MAX-PWR	none	Amps	Amps	-
AMPS/T-MAX-PWR	none	1/°C	1/°C	-
C0, C1, C2	none	none	none	-
C3	none	1/Volts	1/Volts	-
FDIODE	none	none	none	-

Miscellaneous

COST-DATA

Accepts the U-name of a MATERIALS-COST command. This command allows you to define first costs, maintenance costs, etc. for the loop.

EQUIPMENT-REPORTS

Accepts the codewords YES or NO. The default is YES. When report PS-H of the PLANT-REPORTS is enabled, a report will print for this component unless this keyword is set to NO.

ELEC-METER

Defines a meter to which an electrical end use can be attached. A meter reports the energy consumption and demand for the end uses attached to it. Also, you can associate a utility rate schedule to a meter so that the ECONOMICS program can calculate the energy cost associated with the meter. Multiple meters can be defined, allowing you to disaggregate energy use and cost.

Three types of meters can be defined: UTILITY, BUILDING, and SUB-METER. These types correspond to three different levels, with SUB-METER being the lowest, BUILDING being the middle, and UTILITY being the highest. The intention is that all meters that are to be connected to a UTILITY-RATE should be of TYPE = UTILITY. (This restriction is not enforced, but if another type of meter is connected to a UTILITY-RATE there will most likely be double counting of energy consumption by the ECONOMICS program. Note, however, that you might want to take advantage of listing BUILDING or SUB-METERS in a UTILITY-RATE if submeters exist for various tenants in a building, and you wish to have the program calculate the charges for each tenant.)

A fourth TYPE of ELEC-METER also exists: ELECTRIC-SALE. This type of meter accepts the output of electric generators that will be sold to a utility. It is not possible to attach any electric demands (such as lighting) to this meter. Only generators can attach to this type of meter, so that their power can be sold. Each meter type, including ELECTRIC-SALE, can have associated transformers which can include losses and part-load performance characteristics.

All non-UTILITY types of meters must be attached to an ELEC-METER of a higher level; each SUB-METER must be attached to one (and only one) BUILDING or UTILITY meter, and each BUILDING meter must be attached to one (and only one) UTILITY meter. In this way a three-level tree is constructed that contains all the meters. The consumption/demand for the BUILDING and SUB-METER levels is summed into their parent ELEC-METER; thus, reports for UTILITY and BUILDING meters contain the component consumption/demand of all lower level (child) meters.

This structure allows you to describe a site (with a site substation transformer) with multiple buildings, each with its own BUILDING meter plus transformer and, possibly, floor-by-floor SUB-METERS and transformer.

Example input:

```

BANKinB1 = ELEC-METER
  TYPE           = SUB-METER
  TRANSFORMER-SIZE = 15 ..

FLOOR2inB1 = ELEC-METER
  TYPE           = SUB-METER
  TRANSFORMER-SIZE = 10 ..

FLOOR3inB1 = ELEC-METER
  TYPE           = SUB-METER
  TRANSFORMER-SIZE = 10 ..

STOREinB2  = ELEC-METER
  TYPE           = SUB-METER
  TRANSFORMER-SIZE = 20 ..

FLOOR2inB2 = ELEC-METER
  TYPE           = SUB-METER
  TRANSFORMER-SIZE = 10 ..

```

```

OFFICE-BUILDING-1 = ELEC-METER
  TYPE              = BUILDING
  TRANSFORMER-SIZE = 30
  SUB-METERS        = (BANKinB1, FLOOR2inB1, FLOOR3inB1) ..

OFFICE-BUILDING-2 = ELEC-METER
  TYPE              = BUILDING
  TRANSFORMER-SIZE = 25
  SUB-METERS        = (STOREinB2, FLOOR2inB2) ..

SUBSTATION = ELEC-METER                $ utility-owned
  TYPE      = UTILITY                   $ no transformer;
  BLDG/SUB-METERS = (OFFICE-BUILDING-1,
                    OFFICE-BUILDING-2) ..
    
```

TYPE

Takes a code-word that defines the level of the meter. This is a required keyword. Allowed code-words are:

- UTILITY The meter is intended to be connected to a UTILITY-RATE. Its children are connected by use of the BLDG/SUB-METERS keyword. This type of meter is intended to be the main meter for a site (although you may define several meters of this type).
- BUILDING The meter is intended to be one, of possibly many, building or "client" meters at a site. This type of meter must be connected to an ELEC-METER of TYPE = UTILITY. Its children are connected by use of the SUB-METERS keyword.
- SUB-METER This type of meter should be connected to an ELEC-METER of TYPE = BUILDING, but may instead be attached to an ELEC-METER of TYPE = UTILITY. This type of meter is intended to be one, of possibly many, sub-meters or "client" meters at a site.
- ELECTRIC-SALE This type of meter is a special meter that accepts electricity produced by ELEC-GENERATORS for sale to a utility. No other types of loads, such as lighting, may attach to this meter.

UNIT-INDEX

An integer value that defines the billing unit as listed in the units table (see Appendix A). This value is used in the reports, and allows English units to be converted to the correct metric units. The default is 54, which corresponds to kWh in both English and metric units.

DEM-UNIT-INDEX

An integer value that defines the billing unit of peak demand as listed in the units table (see Appendix A). This value is used in the reports and allows English units to be converted to the correct metric units. The default is 28, which corresponds to kW in both English units and metric units.

SOURCE-SITE-EFF

The ratio between the energy delivered to the building site and the source energy (the energy used by the utility to generate the energy delivered to the building).

INTERIOR-POWER

Accepts a list of up to 10 values of hourly electrical energy consumed by miscellaneous uses inside the building that do not show up anywhere else. This energy shows up as a load on the meter, but does not appear as either a space load or as a circulation loop load. Use INTERIOR-SCH, below, to schedule interior power.

INTERIOR-SCH

Accepts a list of up to 10 U-Names of schedules with TYPE = MULTIPLIER that modify the INTERIOR-POWER values on an hourly basis.

INTERIOR-EU

Accepts a list of up to 10 code-words specifying the end-use category of the INTERIOR-POWER. The code-words correspond to the end-use categories in the end-use reports (PS-E, PS-F, BEPS, BEPU). Acceptable entries are LIGHTS, TASK-LIGHTS, MISC-EQUIP, SPACE-HEATING, SPACE-COOLING, HEAT-REJECT, PUMPS&AUX, VENT-FANS, REFRIG-DISPLAY, HT-PUMP-SUPPLEM, DOMEST-HOT-WTR, and EXT-USAGE.

Note that, while exterior energy can be entered via the EXTERIOR-POWER keyword, it may also be entered via the INTERIOR-POWER and INTERIOR-EU = EXT-USAGE keywords. The same is true for REFG-POWER

EXTERIOR-POWER

Accepts a list of up to 10 values of hourly electrical energy consumed by miscellaneous uses outside the building that do not show up anywhere else. This energy shows up as a load on the meter, but does not appear as either a space load or as a circulation loop load. Use EXTERIOR-SCH, below, to schedule exterior power.

EXTERIOR-SCH

Accepts a list of up to 10 U-Names of schedules with TYPE = MULTIPLIER that modify the EXTERIOR-POWER values on an hourly basis.

EXTERIOR-EU

Accepts a list of up to 10 code-words specifying the end-use category of the EXTERIOR-POWER. The code-words correspond to the end-use categories in the end-use reports (PS-E, PS-F, BEPS, BEPU, TDV1 TDV2). Acceptable entries are LIGHTS, TASK-LIGHTS, MISC-EQUIP, SPACE-HEATING, SPACE-COOLING, HEAT-REJECT, PUMPS&AUX, VENT-FANS, REFRIG-DISPLAY, HT-PUMP-SUPPLEM, DOMEST-HOT-WTR, and EXT-USAGE.

Note that, while exterior energy can be entered via the EXTERIOR-POWER keyword, it may also be entered via the INTERIOR-POWER and INTERIOR-EU = EXT-USAGE keywords.

REFG-POWER

Accepts numeric entry of the hourly electrical energy consumed by miscellaneous refrigeration applications that do not show up anywhere else. This energy shows up as a load on the meter, but does not appear as either a space load or as a circulation loop load. Use REFG-SCH, below, to schedule exterior power.

REFG-SCH

Accepts the U-Name of a schedule with TYPE = MULTIPLIER that modifies the REFG-POWER value on an hourly basis.

METER-REPORT

Takes a code-word YES (the default) or NO that determines if reports are to be output for this meter.

TRANSFORMER-SIZE

The capacity of the transformer for this meter. There is no default; if no value is specified then no transformer is simulated for this meter (and thus the keywords TRANSFORMER-LOSS and TRANS-LOSS-FPLR are not used).

TRANSFORMER-LOSS

The fraction of output power that is lost at the transformer at full load conditions (full load is equal to TRANSFORMER-SIZE).

TRANS-LOSS-FPLR

Takes the U-name of a curve that gives the multiplier on TRANSFORMER-LOSS as a function of the part load ratio (current hour load on the meter divided by TRANSFORMER-SIZE). The transformer loss is calculated hourly as

$$(\text{TRANSFORMER-SIZE}) \times (\text{TRANSFORMER-LOSS}) \times (\text{TRANS-LOSS-FPLR value})$$

The load is the sum of that due to all directly connected equipment and, for TYPE = UTILITY and BUILDING, other ELEC-METERS. The default curve is linear from 0.1 at zero load to 1.0 at full load.

BLDG/SUB-METERS

Accepts a list of U-names of ELEC-METER commands that are supplied from this meter. This keyword is only used for ELEC-METERS of TYPE = UTILITY. The ELEC-METERS that are in this list can only be of TYPE = BUILDING or SUB-METER. Each ELEC-METER of TYPE = BUILDING must appear in this list for one of the ELEC-METERS of TYPE = UTILITY. A BUILDING meter cannot be listed as a child for more than one UTILITY meter, as this would cause power to be double-counted. The program checks for this condition and will generate an error if you attempt to do so. Each ELEC-METERS of TYPE = SUB-METER must appear in either this list for one of the ELEC-METERS of TYPE = UTILITY, or in the SUB-METERS list for one of the ELEC-METERS of TYPE = BUILDING. As for BUILDING type meters, a given SUB-METER cannot be a child of more than one meter, or power will be double-counted.

SUB-METERS

Accepts a list of U-names of ELEC-METERS of TYPE = SUB-METER that are supplied from this meter. This keyword is only used for ELEC-METERS of TYPE = BUILDING. There is no default for this keyword. Each ELEC-METER of TYPE = SUB-METER must be included in a list for either a BUILDING meter or a UTILITY meter. Each SUB-METER can only be attached to one higher level meter to avoid double-counting energy.

Electric generators

The following set of keywords applies only to meters having attached electric generators. The program can model relatively complex cogeneration control schemes. Please refer to the *DOE-2.2 Topics* for more information on generator control.

COGEN-TRACK-MODE

For UTILITY and ELEC-SALE types, accepts a code-word that describes how the cogeneration equipment attached to this meter is to be controlled. This keyword can be overridden by the COGEN-TRACK-SCH keyword. In the following, each code-word is followed by a number in parenthesis. The code-word applies to this keyword, and the number in parenthesis the flag value that is equivalent to the code-word when the COGEN-TRACK-SCH is used:

DONT-RUN (0)	Specifies that the generators are shut off. This mode of operation allows a COGEN-TRACK-SCH to shut off the generators during certain times of the day or year.
--------------	---

- TRACK-ELEC (1)** Specifies that the generators are to track the meter's electrical load. This mode works only for UTILITY electric meters, as ELECTRIC-SALE meters do not have any demands that can be tracked.
- TRACK-THERMAL (2)** Specifies that the generators are to track the thermal load of an attached CIRCULATION-LOOP. For this mode to work, each attached generator must also be attached to a CIRCULATION-LOOP. Note that, while multiple generators may be on the same ELEC-METER, each of these generators may be attached to the same or different CIRCULATION-LOOPS, and may therefore be tracking the same or different thermal loads when operating in this mode.
- When using this mode with a UTILITY meter, it is possible that the generators might produce more electricity than this meter demands. In this case, you should also attach each generator to a meter of type ELECTRIC-SALE (via the generator's SURPLUS-SALE keyword); otherwise the surplus power will be lost.
- When using this mode with an ELECTRIC-SALE meter (as the ELEC-METER, not the SURPLUS-METER), all power will be sold. The amount generated and sold will then be a function of the thermal demands.
- TRACK-LESSER (3)** Specifies that each generator is to track the smaller of this meter's electric demand, and the thermal demand of the generator's attached CIRCULATION-LOOP. This mode works only for UTILITY electric meters, and only when the generators are also attached to CIRCULATION-LOOP(s).
- TRACK-GREATER (4)** Specifies that each generator is to track the greater of this meter's electric demand, and the thermal demand of the generator's attached CIRCULATION-LOOP. This mode works only for UTILITY electric meters, and only when the generators are also attached to CIRCULATION-LOOP(s).
- When using this mode, it is possible that the generators might produce more electricity than this meter demands. In this case, you should also attach each generator to a meter of type ELECTRIC-SALE (via the generator's SURPLUS-SALE keyword); otherwise the surplus power will be lost.
- MAX-OUTPUT (5)** Specifies that the generators are to run at maximum output. When using this mode with a UTILITY meter, it is possible that the generators might produce more electricity than this meter demands. In this case, you should also attach each generator to a meter of type ELECTRIC-SALE (via the generator's SURPLUS-SALE keyword); otherwise the surplus power will be lost.

COGEN-TRACK-SCH

For UTILITY and ELEC-SALE types, accepts the U-name of a SCHEDULE of TYPE = FLAG. Acceptable flag values are 0, 1, 2, 3, 4, and 5, and have the meaning as described for COGEN-TRACK-MODE. When specified, this schedule will override any value given for COGEN-TRACK-MODE. This keyword allows the operational mode of generators to shift according to the time of day or year.

EQUIP-CTRL

For a UTILITY meter, accepts the U-name of an EQUIP-CTRL of TYPE = ELECTRICAL that coordinates the operation of multiple generators attached to this meter. In addition, this sequence can operate the generator(s) in a peak shaving mode so that the generators only pick up the load above some upper limit. A LOAD-MANAGEMENT command can select an EQUIP-CTRL sequence that overrides this sequences on the basis of a

schedule, outdoor air temperature, etc. This keyword can be used with any of the electric tracking modes (TRACK-ELEC, TRACK-LESSER, TRACK-GREATER); it is ignored for all of the other modes (DONT-RUN, TRACK-THERMAL, MAX-OUTPUT). If not specified, then the program will automatically select the mix of generators that best matches the hourly load. Note that, when tracking thermal loads (TRACK-THERMAL, TRACK-LESSER, TRACK-GREATER), the generator acts as though it were a boiler, and its operation can be coordinated with boilers and/or other generators via the HEAT-EQUIP-CTRL keyword in the CIRCULATION-LOOP command.

EQUIP-CTRL

Specifies how primary heating and cooling equipment is to be used to meet the loads on a CIRCULATION-LOOP or ELEC-METER to which this equipment is attached. For example, an EQUIP-CTRL sequence can be defined to specify the sequence of chillers used for each of several different chilled water load ranges. This command allows you to override the default load allocation routines (in which the program automatically selects the mix of equipment with a combined capacity most closely matching the load but preventing an overload condition).

If you wish to use the same EQUIP-CTRL sequence all year for a given CIRCULATION-LOOP or ELEC-METER, then you can define a single EQUIP-CTRL sequence and reference it directly from the CIRCULATION-LOOP command. On the other hand, to change control strategies on a time-of-use basis or to implement an electrical peak shaving strategy, then you must define multiple EQUIP-CTRL sequences for a given loop and use the LOAD-MANAGEMENT command to select the appropriate sequence on an hourly basis.

An EQUIP-CTRL command can apply to only one CIRCULATION-LOOP or ELEC-METER. This is a direct consequence of the fact that any given piece of primary equipment can be attached to only one load.

Example input:

```
"EM1" = ELEC-METER
  TYPE                = UTILITY
  COGEN-TRACK-MODE    = TRACK-ELEC
  EQUIP-CTRL          = "Gen Ctrl" ..

"FM1" = FUEL-METER
  TYPE                = NATURAL-GAS ..

MASTER-METERS
  MSTR-ELEC-METER     = "EM1"
  MSTR-FUEL-METER     = "FM20" ..

"Generator 100" = ELEC-GENERATOR
  TYPE                = GAS-TURBINE-GENERATOR
  CAPACITY            = 100                $ kW
  ELEC-METER          = "EM1"
  EXH-LOOP            = "Heating Loop" ..

"Generator 200" = ELEC-GENERATOR
  TYPE                = GAS-TURBINE-GENERATOR
  CAPACITY            = 200                $ kW
  ELEC-METER          = "EM1"
  EXH-LOOP            = "Heating Loop" ..

"Gen Ctrl" = EQUIP-CTRL
  TYPE                = ELECTRICAL
  ELEC-METER          = "EM1"
  METER-SEQ-1         = 1                  $ 1st 30 kW
  METER-MAX-LOAD-1    = 30                $ no equipment
  GENERATORS-2        = ("Generator 100")  $ ~ 30-100 kW
  GENERATORS-3        = ("Generator 200",  $ ~100+ kW
                        "Generator 100") .. $ ~200+ kW
```

TYPE

Takes a code-word that specifies the type of equipment and circulation loop to which this control sequence will be linked. This is a required keyword. Allowed values are:

COOLING	Controls CHILLERS, cold THERMAL-STORAGE equipment and CHW-METERS on loops of type CHW and PIPE2.
HEATING	Controls BOILERS, the heating mode of CHILLER/HEATERS, the thermal-tracking mode of ELEC-GENERATORS, hot THERMAL-STORAGE equipment and STEAM-METERS on loops of type HW, PIPE2, and WLHP.
DW-HEATING	Controls DW-HEATERS, the thermal-tracking mode of ELEC-GENERATORS and STEAM-METERS on DHW loops.
HEAT-REJECTION	Controls COOLING-TWRs and GROUND-LOOP-HXs on loops of type CW and WLHP.
ELECTRICAL	Controls ELEC-GENERATORS and ELEC-METERS.

The following keyword groups, which depend on the control type, are used to define the equipment control sequence:

TYPE = COOLING

CIRCULATION-LOOP

Takes the U-name of the CIRCULATION-LOOP to which this EQUIP-CTRL applies. This keyword is mandatory; the program uses this information to ensure that all equipment referenced by this command is also attached to the same loop.

CHILLERS-1

CHILLERS-2

CHILLERS-3

CHILLERS-4

CHILLERS-5

CHILLERS-n accepts a list of U-names of up to 10 CHILLERS that are to be used to meet the nth load range, where the load range is the sum of the hourly operating capacities of the equipment listed here. All of the CHILLERS listed must be attached to the same loop.

CHILLERS-SEQ-1

CHILLERS-SEQ-2

CHILLERS-SEQ-3

CHILLERS-SEQ-4

CHILLERS-SEQ-5

CHILLERS-SEQ-n accepts a list of integer values between 1 and 10 that correspond to the equipment listed in CHILLERS-n. These values specify the order in which the equipment is to be started.

MAX-LOAD-1

MAX-LOAD-2

MAX-LOAD-3

MAX-LOAD-4

MAX-LOAD-5

MAX-LOAD-n accepts a list of values that correspond to the equipment listed in CHILLERS-n. These values are the maximum load that each unit is to be given. The default is no limit. You can specify up to five sets of load range keywords; the second load range is the sum of the hourly operating capacities of the equipment listed in CHILLERS-2, etc.

Example input: Several load ranges using CHILLERS-n and MAX-LOAD-n

Assume a loop has four chillers named CHLR-A, CHLR-B, CHLR-C and CHLR-D. Only three of the chillers are to be used in the first load range; they are listed as CHILLERS-1 = (CHLR-A, CHLR-B, CHLR-C). Note that CHLR-D has not been listed because it is not used in this load range. The EQUIP-SEQ-n may have a variety of values:

- (default, or 1, 2, 3) CHLR-A will be started first. If CHLR-A cannot handle the entire load then CHLR-B will also run. If CHLR-A and CHLR-B cannot handle the load, then CHLR-C will also run. The load will be prorated to all active units based upon their capacity. For example, assume that CHLR-A is a 100-ton unit, CHLR-B is a 200-ton unit and CHLR-C is a 500-ton unit. If the load is 90 tons, then only CHLR-A will run. If the load is 120 tons, then CHLR-A and CHLR-B will both start, and will operate at 40 and 80 tons respectively. If the load is 500 tons, then all three chillers will run, with loads of 62.5 tons, 125 tons, and 312.5 tons, respectively. (If in reality you only want CHLR-C operating to handle a 500 ton load, then this sequence should be entered in a separate load range.)
- (3, 2, 1) CHLR-C will start first, then CHLR-B, and finally CHLR-A.
- (1, 3, 2) CHLR-A will start first, then CHLR-C, and finally CHLR-B.
- (1, 1, 2) CHLR-A and CHLR-B will always start and run together, followed by CHLR-C. Using the above example, if the cooling load is only 90 tons, then both CHLR-A and CHLR-B will start and run at 30 tons and 60 tons, respectively, even though CHLR-A could handle the load by itself.
- (1, 2, 1) CHLR-A and CHLR-C will always start and run together, followed by CHLR-B.

EQUIP-MAX-LOAD-1 can now be used to limit the load on each piece of equipment in the above cases. For example, to limit CHLR-B to a load of 150 tons (1.8x106 Btuh), while the other units are to be unrestricted, you can input EQUIP-MAX-LOAD = (999.0, 1.8, 999.0). The loop load will then be prorated to each unit on the basis of unit capacity, or these values, whichever are less.

As mentioned in the above examples, you might want to only allow CHLR-C to run when the load is larger than the combined capacity of CHLR-A and CHLR-B, and then stage CHLR-A and CHLR-B back on as the load continues to increase beyond what CHLR-C can handle. The following input illustrates this concept.

```

CHILLERS-1          = (CHLR-A,CHLR-B)          $ Up to 300 tons
CHILLERS-SEQ-1      = (      1,      2)        $ 100, 200 tons cap
                                                            $ CHLR-A first,
                                                            $ then A+B

                                                            $ Over 300 tons, use
                                                            $ CHLR-C first, then
                                                            $ C+B, then C+B+A
CHILLERS-2          = (CHLR-A,CHLR-B,CHLR-C)
CHILLERS-SEQ-2      = (      3,      2,      1)
..
    
```

Assignment of Thermal Storage Equipment

The EQUIP-CTRL command is also used to coordinate the assignment of THERMAL-STORAGE equipment along with conventional equipment to meet a loop load. An EQUIP-CTRL command must be defined in order to use a THERMAL-STORAGE device; there are no default allocation algorithms for this class of equipment. The major difference between the assignment of storage and conventional equipment is that, while a loop may be supplied by multiple chillers, it may be supplied by only one storage device. For this reason, the storage device is not explicitly named in the EQUIP-CTRL sequences, instead it is attached to the loop through the use of the SUPPLY-TO-LOOP keyword in a previously defined THERMAL-STORAGE command. The following two keywords are used for thermal storage devices.

- STORE-SEQ-1**
- STORE-SEQ-2**
- STORE-SEQ-3**
- STORE-SEQ-4**
- STORE-SEQ-5**

An integer value that specifies the loading sequence for the storage device. This value must be coordinated with the values in the CHILLERS-SEQ-1 keyword to allow the storage device to be used in the desired sequence with the conventional equipment (see the following example).

- STORE-MAX-LOAD-1**
- STORE-MAX-LOAD-2**
- STORE-MAX-LOAD-3**
- STORE-MAX-LOAD-4**
- STORE-MAX-LOAD-5**

The maximum load that the storage device can supply to the loop. If not specified, the device will give up to its maximum output as specified by the THERMAL-STORAGE command. Unlike chillers, the load assigned to a storage device is not prorated based on capacity. Instead, the assigned load depends on the order in which the storage device is activated relative to the other equipment.

For example, assume that CHLR-A and CHLR-B are 100 tons and 200 tons, respectively, and that a cold storage device is also attached to the loop. If the chillers are to handle the first 300 tons and cold storage is to handle the load above 300 tons, input is as follows:

```

CHILLERS-1          = (CHLR-A,CHLR-B)
CHILLERS-SEQ-1     = (    1,    2)      $ CHLR-A first,
                                           $ then A+B
STORE-SEQ-1        = (3)              $ all loads above
                                           $ what the chillers
                                           $ can handle
    
```

If, instead, the cold storage device is to handle the first 300 tons, with the rest picked up by the chillers, the input would be:

```

CHILLERS-1          = (CHLR-A,CHLR-B)
CHILLERS-SEQ-1     = (    2,    3)
STORE-SEQ-1        = (1)              $ The tank loads
STORE-MAX-LOAD-1   = (3.6)           $ first up to 300
                                           $ tons; chillers pick
                                           $ up the remainder
    
```

Note that, for clarity, the order of these keywords can be changed and give the same result:

```

STORE-SEQ-1      = ( 1 )           $ The tank loads
STORE-MAX-LOAD-1 = ( 3.6 )         $ first to 300 tons;
CHILLERS-1       = ( CHLR-A,CHLR-B) $ chillers pick up
CHILLERS-SEQ-1   = (      2,      3) $ the remainder
    
```

To force the load to be prorated to all devices, give them the same sequence number:

```

STORE-SEQ-1      = ( 1 )           $ The tank loads
STORE-MAX-LOAD-1 = ( 3.6 )         $ simultaneously with
CHILLERS-1       = ( CHLR-A,CHLR-B) $ the chillers
CHILLERS-SEQ-1   = (      2,      3)
    
```

Coordinating Equipment Usage with a Chilled-Water Meter

The EQUIP-CTRL command allows equipment usage to be coordinated with a chilled-water meter in a manner analogous to thermal storage. As with storage, the meter is not explicitly named here but is attached to the loop via the CHW-METER keyword in the CIRCULATION-LOOP command; a loop can have at most one meter. Note that, by default, a meter will meet any load not already satisfied by other equipment (typically, there will be no other equipment when you use a meter). The only time you need to reference the meter within an EQUIP-CTRL command is when you want to coordinate the meter usage with other equipment.

- METER-SEQ-1**
- METER-SEQ-2**
- METER-SEQ-3**
- METER-SEQ-4**
- METER-SEQ-5**

An integer value that specifies the loading sequence for the meter. This value should be coordinated with the values in the CHILLERS-SEQUENCE-1 keyword.

- METER-MAX-LOAD-1**
- METER-MAX-LOAD-2**
- METER-MAX-LOAD-3**
- METER-MAX-LOAD-4**
- METER-MAX-LOAD-5**

The maximum load that the meter can supply to the loop. If not specified, the meter will give up to its maximum output as specified by the MAX-SUPPLY-RATE keyword in the CHW-METER command. For example, assume that CHLR-A and CHLR-B are 100 tons and 200 tons, respectively, and that a CHW-METER has been attached to the loop. If the chillers are to handle the first 300 tons, and the meter is to handle the portion of the load above 300 tons, input is as follows.

```

CHILLERS-1      = ( CHLR-A,CHLR-B) $ 100 and 200 tons
CHILLERS-SEQ-1  = (      1,      2) $ CHLR-A first,
                                     $ then A+B
    
```

In this example the meter could have been listed, but there is no need to do this since, by default, an assigned meter will always pick up any load not satisfied by other equipment. If, instead, the meter is to handle the first 300 tons, with the rest picked up by the chillers, the input would be:

```

METER-SEQ-1      = ( 1 )           $ Meter loads first
METER-MAX-LOAD-1 = ( 3.6 )         $ up to 300 tons,
CHILLERS-1       = ( CHLR-A,CHLR-B) $ chillers pick up
CHILLERS-SEQ-1   = (      2,      3) $ the remainder
    
```

PRORATE-LOAD

accepts a code-word specifying whether the load should be prorated to all active equipment units, or allocated according to the sequence number.

When an EQUIP-CTRL sequence finds it necessary to use more than one equipment unit, the program will normally prorate the load to all units activated based on their hourly operating capacity. For example, if a heating load is 100,000 Btuh and two boilers are selected having capacities of 50,000 and 75,000 Btuh, then the program will give the two boilers 40,000 and 60,000 Btuh loads respectively. The following keyword allows you to override this proration, and load the units according to their sequence number

YES	the default, means the load will be prorated. For example, if a heating load is 100,000 Btuh and two boilers are selected having capacities of 50,000 and 75,000 Btuh, then the program will give the two boilers 40,000 and 60,000 Btuh loads respectively.
NO	means the load will not be prorated, but will be assigned in the according to the sequence number. In the previous example, if the smaller boiler had a sequence number of 1 and the larger boiler a sequence number of two, then the smaller boiler would be fully loaded to 50,000 Btuh (or up to the unit's maximum operating capacity), and the larger boiler given the remaining 50,000 Btuh.

Note that if two units have the same sequence number, then the program will sequentially load any units having a lower sequence number, then prorate the load to any units having the same sequence number (up to fully loaded if necessary), and then sequentially load any remaining units having a higher sequence number.

Other EQUIP-CTRL Types

The above description was for EQUIP-CTRL commands of TYPE = COOLING. Other EQUIP-CTRL types have identical or similar keywords, with the following exceptions:

TYPE = HEATING

The storage and meter keywords are identical, and have identical functions. Other keywords are:

BOILERS-1
BOILERS-2
BOILERS-3
BOILERS-4
BOILERS-5

BOILERS-n accepts a list of U-names of up to 10 BOILERS that are to be used to meet the nth load range, where the load range is the sum of the hourly operating capacities of the equipment listed here. All of the BOILERS listed must be attached to the same loop.

BOILERS-SEQ-1
BOILERS-SEQ-2
BOILERS-SEQ-3
BOILERS-SEQ-4
BOILERS-SEQ-5

BOILERS-SEQ-n accepts a list of integer values between 1 and 10 that correspond to the equipment listed in BOILERS-n. These values specify the order in which the equipment is to be started.

CHLR/HTRS-1**CHLR/HTRS-2****CHLR/HTRS-3****CHLR/HTRS-4****CHLR/HTRS-5**

CHLR/HTRS-n takes a list of U-names of up to 10 CHILLERS that can *actively operate in a heating mode*, and whose heat output is to be used to meet the heating load. *Actively operate in a heating mode* means a chiller that can directly produce heat that is not a byproduct of cooling, such as a gas-fired chiller/heater, air-source heat pump, water-source heat pump, and loop-to-loop heat pump (GAS-ABSOR, AIR-SOURCE-HP, WATER-SOURCE-HP, LOOP-TO-LOOP-HP). Heat recovered from other types of chillers is available only as a byproduct of cooling and is considered *passive heat*. Passive heat recovery, when available to a loop, is always used prior to boilers, etc. and is not controlled via an EQUIP-CTRL sequence.

When used together with BOILERS-1 through BOILERS-5, this keyword allows you (1) to enable a CHILLER in the heating mode, or (2) to coordinate the heat output of chiller/heaters with boilers, electric generators, thermal storage, and steam meters. Note that this keyword applies only to an EQUIP-CTRL of TYPE = HEATING, and applies only to the heating output of a chillers that can actively operate in a heating mode. It does not apply to cooling; for cooling you control a chiller/heater like any other chiller using the CHILLERS-1 through CHILLERS-5 keywords in an EQUIP-CTRL:TYPE = COOLING.

CHLR/HTRS-SEQ-1**CHLR/HTRS-SEQ-2****CHLR/HTRS-SEQ-3****CHLR/HTRS-SEQ-4****CHLR/HTRS-SEQ-5**

Accept a list of integer values between 1 and 10 that correspond to the equipment listed in CHLR/HTRS-1 through CHLR/HTRS-5. These values specify the order in which the equipment is to be started. Used in addition to BOILERS-SEQ-1 through BOILERS-SEQ-5 to coordinate the sequencing of chillers that can actively provide heat with the other heating equipment that may exist.

CHLR/HTRS-MAX-1**CHLR/HTRS-MAX-2****CHLR/HTRS-MAX-3****CHLR/HTRS-MAX-4****CHLR/HTRS-MAX-5**

Accepts a list of values that correspond to the equipment listed in CHLR/HTRS-1 through CHLR/HTRS-5. The values are the maximum heating load that each unit is to be given.

Coordinating Electric Generators in the Thermal Tracking Mode with Other Equipment

The following three keywords allow you to coordinate the use of one or more electric generators in the thermal tracking mode with other generators in the same mode, with boilers, and/or with chiller/heaters. These keywords apply only when the EQUIP-CTRL:TYPE = HEATING and generators are attached to the loop. These keywords apply only when the generators are thermal tracking as specified in their parent ELEC-METER; the electric tracking mode of these devices is controlled using EQUIP-CTRL:TYPE = ELECTRICAL.

GENERATORS-1
GENERATORS-2
GENERATORS-3
GENERATORS-4
GENERATORS-5

Accepts a list of U-names of the electric generators whose heating mode will be used to match the sets of load ranges. There is no default. The equipment listed must be attached to the same loop as this EQUIP-CTRL sequence; otherwise serious errors will result. Currently, the program does not check to see if this requirement is met.

GENERATORS-SEQ-1
GENERATORS-SEQ-2
GENERATORS-SEQ-3
GENERATORS-SEQ-4
GENERATORS-SEQ-5

Accepts a list of integers from 1 to 10 corresponding to and entered in the same order as the equipment listed in GENERATORS-1 through GENERATORS-5. These numbers specify the order in which the equipment will start to satisfy the load. The default is that the equipment will start in the order listed.

All rules for sequencing described under EQUIP-CTRL:EQUIP-SEQ-1 through EQUIP-SEQ-5 also apply here. The program will coordinate the sequence numbers listed here for generators with any sequence numbers entered for boilers under EQUIP-CTRL:EQUIP-SEQ-1 through EQUIP-SEQ-5 and any sequence number entered for chiller/heaters under EQUIP-CTRL:CHLR/HTRS-SEQ-1 through CHLR/HTRS-SEQ-5.

GENERATORS-MAX-1
GENERATORS-MAX-2
GENERATORS-MAX-3
GENERATORS-MAX-4
GENERATORS-MAX-5

Accepts a list of values corresponding to and entered in the same order as the equipment listed in GENERATORS-1 through GENERATORS-5. These numbers specify the maximum load that each equipment unit will be given. If not specified, the maximum load will default to each unit's maximum hourly operating capacity. If specified, this value will act as an upper limit on each unit's load. In no case, however, will a unit be assigned a load greater than its hourly operating capacity.

TYPE = DW-HEATING

No thermal storage keywords are allowed for this TYPE since water heaters already have internal storage tanks. STEAM-METERS can be controlled using the meter keywords described for cooling. Generators can also provide heat to domestic hot water loop, and are controlled using the keywords described for HEATING. Other keywords are:

DW-HEATERS-1
DW-HEATERS-2
DW-HEATERS-3
DW-HEATERS-4
DW-HEATERS-5

For TYPE = DW-HEATING, accepts a list of U-names of the DW-HEATERS that will be used to match the sets of load ranges. There is no default. The equipment listed must be attached to the same loop as this EQUIP-CTRL sequence; otherwise serious errors will result. Currently, the program does not check to see if this requirement is met.

DW-HEATERS-SEQ-1**DW-HEATERS-SEQ-2****DW-HEATERS-SEQ-3****DW-HEATERS-SEQ-4****DW-HEATERS-SEQ-5**

Accepts a list of integers from 1 to 10 corresponding to and entered in the same order as the equipment listed in DW-HEATERS-1 through DW-HEATERS-5. These numbers specify the order in which the equipment will start to satisfy the load. The default is that the equipment will start in the order listed.

TYPE = HEAT-REJECTION

No thermal storage keywords or meters are used for this TYPE. Other keywords are:

HEAT-REJ-1**HEAT-REJ-2****HEAT-REJ-3****HEAT-REJ-4****HEAT-REJ-5**

For TYPE = HEAT-REJECTION, accepts a list of U-names of the HEAT-REJECTION components that will be used to match the set of load ranges. There is no default. The equipment listed must be attached to the same loop as this EQUIP-CTRL sequence; otherwise serious errors will result. Currently, the program does not check to see if this requirement is met.

HEAT-REJ-SEQ-1**HEAT-REJ-SEQ-2****HEAT-REJ-SEQ-3****HEAT-REJ-SEQ-4****HEAT-REJ-SEQ-5**

Accepts a list of integers from 1 to 10 corresponding to and entered in the same order as the equipment listed in HEAT-REJ-1 through HEAT-REJ-5. These numbers specify the order in which the equipment will start to satisfy the load. The default is that the equipment will start in the order listed.

MAX-LOAD-1**MAX-LOAD-2****MAX-LOAD-3****MAX-LOAD-4****MAX-LOAD-5**

are unused for this TYPE = HEAT-REJECTION.

TYPE = ELECTRICAL**ELEC-METER**

Takes the U-name of an ELEC-METER command. This keyword is used instead of CIRCULATION-LOOP. The meter will typically be of TYPE = UTILITY, although it may also be of type BUILDING or SUBMETER. Note that both the UTILITY and BUILDING meters may actually represent a grouping of submeters.

GENERATORS-1
GENERATORS-2
GENERATORS-3
GENERATORS-4
GENERATORS-5

GENERATORS-n accepts a list of U-names of up to 10 GENERATORS that are to be used to meet the nth load range, where the load range is the sum of the hourly operating capacities of the equipment listed here. All of the GENERATORS listed must be attached to the same loop.

GENERATORS-SEQ-1
GENERATORS-SEQ-2
GENERATORS-SEQ-3
GENERATORS-SEQ-4
GENERATORS-SEQ-5

GENERATORS-SEQ-n accepts a list of integer values between 1 and 10 that correspond to the equipment listed in GENERATORS -n. These values specify the order in which the equipment is to be started.

MAX-LOADS-1
MAX-LOADS-2
MAX-LOADS-3
MAX-LOADS-4
MAX-LOADS-5

The maximum electrical load corresponding to each generator in GENERATORS-1,5.

Ground-Loop Heat-Exchangers and Fluid Coolers in parallel on WLHP loops

The program can simulate GROUND-LOOP-HXs together with cooling towers. Often, it may not be economical to size the well field large enough to handle the peak cooling loads, especially for buildings that are cooling-dominated. In this case, it may be desirable to install a fluid cooler in parallel with the well field. A common control strategy would be to allocate as much of the flow to the well field as can be cooled to the loop setpoint, and pass the rest of the flow to the fluid cooler. An example follows.

Note that ground-loop heat-exchangers can be integrated with heat-rejection devices only; they cannot be satisfactorily integrated with boilers.

The following keywords allow you to coordinate the use of one or more ground-loop heat-exchangers (GLHX) with one or more heat-rejection components, such as a fluid cooler. These keywords apply only when the EQUIP-CTRL:TYPE = HEAT-REJECTION. These keywords apply only to the heat-rejection mode of a CW or WLHP loop; they cannot be used to control GLHXs in the heating mode.

GLHX-1
GLHX-2
GLHX-3
GLHX-4
GLHX-5

for TYPE = HEAT-REJECTION, accepts a list of U-names of the GLHXs whose heat-rejection mode will be used in sets of load ranges. There is no default.

The equipment listed must be attached to the same loop as this EQUIP-CTRL sequence. Serious errors will result otherwise. Currently, the program does not check to see if this requirement is met.

GLHX-SEQ-1**GLHX-SEQ-2****GLHX-SEQ-3****GLHX-SEQ-4****GLHX-SEQ-5**

accepts a list of whole numbers (integer 1-10) corresponding to and entered in the same order as the equipment listed in GLHX-1,5. These numbers specify the order in which the equipment will start to satisfy the load. The default is that the equipment will start in the order listed.

All rules for sequencing described under EQUIP-SEQ-1 also apply here. The program will coordinate the sequence numbers listed here for GLHXs with any sequence numbers entered for fluid coolers.

GLHX-MAX-1**GLHX-MAX-2****GLHX-MAX-3****GLHX-MAX-4****GLHX-MAX-5**

accepts a list of values corresponding to and entered in the same order as the equipment listed in GLHX-1,5. These numbers specify the maximum flow that each equipment unit will be given. If not specified, the maximum flow will default to each unit's maximum hourly operating capacity. If specified, this value will act as an upper limit on each unit's flow. In no case, however, will a unit be assigned a flow greater than its hourly operating capacity.

Example Input

A building has a ground-loop heat-exchanger that is supplemented by a fluid cooler. When rejecting heat, the well field is to be loaded as fully as possible, and only the surplus load allocated to the fluid cooler.

```
"WLHP Pump" = PUMP
..

"WLHP Loop" = CIRCULATION-LOOP
  LIBRARY-ENTRY      = "DEFAULT-WLHP"
  TYPE               = WLHP
  LOOP-OPERATION     = DEMAND
  MIN-ALARM-T        = 20
  COOL-EQUIP-CTRL    = "Htrej Ctrl"
..

"Fluid Cooler" = HEAT-REJECTION
  TYPE               = FLUID-COOLER
  CW-LOOP            = "WLHP Loop"
  CAPACITY-RATIO     = 1.0
..

"Ground Loop HX" = GROUND-LOOP-HX
  TYPE               = VERT-WELL-FIELD
  CONFIGURATION      = RECTANGLE-4X3
  DEPTH              = 225
  SPACING            = 20
  PIPE-OUTSIDE-DIA   = 1.315
  PIPE-INSIDE-DIA    = 1.075
  U-TUBE-LEG-SEP     = 1
  PIPE-COND          = 0.226
  FIELD-MULTIPLIER   = 4
```

```

REF-GRND-TEMP      = 60
GRND-DIFFUSIVITY   = 0.84
GRND-COND          = 1.4
CIRCULATION-LOOP   = "WLHP Loop"
..

$ Fully load unit having sequence #1, before loading
$ unit having sequence #2

"Htrej Ctrl" = EQUIP-CTRL
TYPE          = HEAT-REJECTION
CIRCULATION-LOOP = "WLHP Loop"
PRORATE-LOAD  = NO
GLHX-1       = ( "Ground Loop HX" )
GLHX-SEQ-1   = ( 1 )
HEAT-REJ-1   = ( "Fluid Cooler" )
HEAT-REJ-SEQ-1 = ( 2 )
..

```

Additional EQUIP-CTRL Rules

For 2-pipe loops that do both heating and cooling, or WLHP loops that do both heating and heat-rejection, you can define two EQUIP-CTRL commands, one for the heating mode and the other for the cooling or heat-rejection mode. You attach both control sequences to the loop using the HEAT-EQUIP-CTRL and COOL-EQUIP-CTRL keywords within the CIRCULATION-LOOP command. If you specify control sequences for ONLY one mode of the loop (such as heating), the operation of the other mode will default.

For 2-pipe loops that do both heating and cooling, you may specify a STEAM-METER and/or a CHW-METER in the CIRCULATION-LOOP command. If you use these meters in the EQUIP-CTRL sequences, the program automatically selects the correct meter depending on the TYPE of the EQUIP-CTRL sequence. The same idea applies to WLHP loops, but only a STEAM-METER is available.

FUEL-METER

Defines a meter to which fuel use can be attached. A meter reports the energy consumption and demand for the end uses attached to it. Also, you can associate a utility rate schedule to a meter so that the ECONOMICS program can calculate the energy cost associated the meter. Multiple meters can be defined, allowing you to disaggregate energy use and cost.

Example input:

```
FM20 = FUEL-METER
      TYPE           = NATURAL-GAS
      SOURCE-SITE-EFF = 0.98 ..
```

TYPE

The type of fuel being metered. This is a required keyword. Acceptable entries are:

NATURAL-GAS	Natural gas
LPG	Liquified petroleum gas. The program assumes this is propane
FUEL-OIL	Fuel oil
DIESEL-OIL	Diesel oil
COAL	Coal
METHANOL	Methyl alcohol
OTHER-FUEL	Allows you to define the characteristics of a less common fuel, such as wood chips or biomass.

ENERGY/UNIT

The size of the billing unit in Btu or Wh in which consumption is measured.

UNIT-INDEX

An integer value that defines the billing unit as listed in the units table (see Appendix A). This value is used in the reports, and allows English units to be converted to the correct metric units. The default varies by fuel type.

DEM-UNIT-INDEX

An integer value that defines the billing unit of peak demand as listed in the units table. This value is used in the reports and allows English units to be converted to the correct metric units. The default varies by fuel type.

SOURCE-SITE-EFF

The ratio between the energy delivered to the building site and the source energy (the energy used by the utility to generate the energy delivered to the building). The program uses this conversion factor in calculating the source energy reported in the BEPS report.

INTERIOR-POWER

Accepts a list of up to 5 values of hourly fuel energy consumed by miscellaneous uses inside the building that do not show up anywhere else. This energy shows up as a load on the meter, but does not appear as either a space load or as a circulation loop load. Use INTERIOR-SCH, below, to schedule interior power.

INTERIOR-SCH

Accepts a list of up to 5 U-Names of schedules with TYPE = MULTIPLIER that modify the INTERIOR-POWER values on an hourly basis.

INTERIOR-EU

Accepts a list of up to 10 code-words specifying the end-use category of the INTERIOR-POWER. The code-words correspond to the end-use categories in the end-use reports (PS-E, PS-F, BEPS, BEPU). Acceptable entries are LIGHTS, TASK-LIGHTS, MISC-EQUIP, SPACE-HEATING, SPACE-COOLING, HEAT-REJECT, PUMPS&AUX, VENT-FANS, REFRIG-DISPLAY, HT-PUMP-SUPPLEM, DOMEST-HOT-WTR, and EXT-USAGE.

Note that, while exterior energy can be entered via the EXTERIOR-POWER keyword, it may also be entered via the INTERIOR-POWER and INTERIOR-EU = EXT-USAGE keywords.

EXTERIOR-POWER

Accepts a list of up to 5 values of hourly energy consumed by miscellaneous uses outside the building that do not show up anywhere else. This energy shows up as a load on the meter, but does not appear as either a space load or as a circulation loop load. Use EXTERIOR-SCH, below, to schedule exterior power.

EXTERIOR-SCH

Accepts a list of up to 5 U-Names of schedules with TYPE = MULTIPLIER that modify the EXTERIOR-POWER values on an hourly basis.

EXTERIOR-EU

Accepts a list of up to 10 code-words specifying the end-use category of the EXTERIOR-POWER. The code-words correspond to the end-use categories in the end-use reports (PS-E, PS-F, BEPS, BEPU, TDV1 TDV2). Acceptable entries are LIGHTS, TASK-LIGHTS, MISC-EQUIP, SPACE-HEATING, SPACE-COOLING, HEAT-REJECT, PUMPS&AUX, VENT-FANS, REFRIG-DISPLAY, HT-PUMP-SUPPLEM, DOMEST-HOT-WTR, and EXT-USAGE.

Note that, while exterior energy can be entered via the EXTERIOR-POWER keyword, it may also be entered via the INTERIOR-POWER and INTERIOR-EU = EXT-USAGE keywords.

METER-REPORT

Takes a code-word YES (the default) or NO that determines if reports are to be output for this meter.

GROUND-LOOP-HX

Defines a heat-exchanger between a water loop and the ground, and, with proper choice of keywords, between a water loop and a pond, river or well.

Water-loop heat-pump systems sometimes use the ground as a heat source and sink. In this case you use GROUND-LOOP-HX to specify the characteristics of the heat pump's ground loop heat-exchanger. This command can also be used to specify the heat-exchanger when the ground is used as a heat sink to cool condenser water.

Chillers may also utilize lake or well water as their heat source/sink. In this case, they utilize a CIRCULATION-LOOP of TYPE = LAKE/WELL, and a GROUND-LOOP-HX also of TYPE = LAKE/WELL.

You can define one or more GROUND-LOOP-HXs, and these components can be attached to the same or different CIRCULATION-LOOPS.

The program models fields of vertical wells as well as trenches containing horizontal piping. Horizontal piping can consist of either straight runs or "slinky" spirals. The ground models, like the rest of the program, use an hourly time step to calculate the ground loop performance.

The models can simulate newly-installed as well as existing systems. You can specify the number of years the system has been installed to allow more accurate ground field initialization. In this way the effects of ground temperature drift can be estimated. The initialization of the ground is done using a 24-hour profile of heat exchange to the ground on the heating and cooling design days. You can provide this profile or let the program calculate it from the building simulation on the design days. If no design days have been specified then the profiles are set to a constant value, from hour 7 to hour 18, equal to the steady state peak heating and cooling loop loads calculated during the sizing of the loop pumps. These heat exchange profiles are used, along with specified heating and cooling peak day numbers, to create one or more years of "history" for the initialization of the ground coupled system.

You specify the ground loop return water temperature as a schedule (LOOP-TEMP-SCH); otherwise it defaults to the ground temperature from the weather file.

You can also specify a "field multiplier." This allows you to define large heat-exchanger systems that consist of two or more identical subsystems with small subsystem-to-subsystem interaction.

Important: unlike other HVAC components, the program cannot currently design a ground loop heat-exchanger system based on the predicted heating and cooling loads. Except for the design flow, you must input all necessary design parameters, such as the number and depth of vertical wells, horizontal trenches, etc. Under-specifying these parameters can result in extreme temperature swings in the outlet temperature of the well field. This may cause the WLHP loop to shut down (if the outlet temperature exceeds CIRCULATION-LOOP:MAX-ALARM-T or MIN-ALARM-T), or may cause the heat-pump performance curves to extrapolate to unreasonable values, yielding results badly in error or possibly fatal to the simulation. You should always specify an hourly report for this component and review the predicted outlet temperature for both winter and summer intervals.

The ground loop heat-exchanger model is considered a test capability at this time (except LAKE/WELL, which is well-tested). We suggest it be used for production work only with very careful examination of the results. You should apply careful engineering judgment to be sure all predictions are reasonable since this feature has not yet been validated against field measurements.

Simulation of Vertical Wells

You can simulate a single vertical well or multiple, parallel vertical wells, used with a ground-source heat pump. A U-tube configuration is assumed. Transient effects in the well and the above-ground loop are neglected. The well is assumed to be in good contact with soil that has uniform properties and is at a constant far-field temperature.

To simulate a ground-coupled water-loop heat-pump system, you define a CIRCULATION-LOOP of TYPE = WLHP and attach heat pumps to the loop in a manner identical to conventional WLHP systems. Instead of attaching a boiler and tower to the loop, you define a GROUND-LOOP-HX and attach it to the loop. The main purpose of the simulation is to determine the temperature of the water loop based on the net heat transfer to the loop during the hour. The ground-loop calculation and the heat pump performance calculation are done separately. This is because of the structure of the program and the possibility of having multiple heat pumps on the same loop, some of which may be in a cooling mode while others are in a heating mode. The performance of the heat pumps is based on the ground-loop temperature return temperature at the end of the previous hour. Alternatively, it can be based on loop temperature setpoints. There are two alternative vertical well modeling methods: a simplified model developed for DOE-2 with 19 different vertical well configurations; a more detailed model based upon the G-function approach utilizing G-functions based upon the techniques developed by researchers in Sweden and calculated via the EED program.

Simulation of Horizontal Loops

You can also simulate a horizontal loop ground heat-exchanger for use with a ground-source heat pump. Both straight tubes and slinky coils can be modeled. Transient effects in the loop are neglected. The loop is assumed to be in good contact with a soil that has uniform properties. As with the vertical well, you define a CIRCULATION-LOOP of TYPE = WLHP and attach heat pumps to the loop in a manner identical to conventional WLHP systems. Instead of a boiler and tower, you define a GROUND-LOOP-HX and attach it to the loop.

As with vertical loops, the ground loop and heat pump are simulated separately; the heat pump calculation uses the previous-hour loop temperature or user-specified loop temperature setpoints.

Six different horizontal straight-tube configurations and two slinky configurations are available. Multiple, parallel trenches can be specified.

Keywords

Care should be taken to specify all parameters relevant to a particular configuration as the program defaults are not robust. It is also suggested that the SYSTEM command default HP unit performance curves be replaced with ones that properly represent the units planned for use; the default curves may not accurately represent the more extreme temperature deviations that a ground-coupled system may experience.

TYPE

Accepts a code-word that specifies the type of ground-coupled heat-exchanger. This keyword is required and should be the first entered. Acceptable values are:

VERT-WELL-FIELD	One or more vertical wells in a field of wells.
VERT-WELL-NEW	One or more vertical wells in a field of wells. This modeling approach is based on the G-function method developed by researchers in Sweden and utilized in the Earth Energy Designer (EED) borehole heat exchanger design software package..
HORIZ-STRAIGHT-LOOP	One or more horizontal trenches with straight-tubes.
HORIZ-SLINKY-LOOP	One or more horizontal trenches with slinky tubing.
LAKE/WELL	The loop return temperature is set equal to the temperature given by LOOP-TEMP-SCH, if specified. If LOOP-TEMP-SCH is not specified the monthly

ground temperature from the weather file is used. This option allows you to simulate water-wells, lakes, and rivers, where the temperature of these sources is driven by factors other than the loop thermal demands. Since the supply temperature is fixed by the schedule, all keywords pertaining to the ground field definition are ignored.

Note that a GROUND-LOOP-HX of TYPE = LAKE/WELL can be attached to CIRCULATION-LOOPs of TYPE = WLHP, CW (condenser water), or LAKE/WELL. This allows chillers or other water-cooled components to be attached to heat sinks like a lake, well, or river rather than a cooling tower or outside air.

LOOP-TEMP-SCH

When the TYPE is equal to LAKE/WELL, this keyword is the U-name of a SCHEDULE of TYPE equal to TEMPERATURE. This schedule sets the hourly return temperature from the ground-loop heat-exchanger. If you do not specify a schedule, the temperature will default to the monthly ground temperature on the weather file.

Vertical Well Systems

The following keywords specify the properties of the well field for a vertical well system.

CONFIGURATION

For TYPE = VERT-WELL-FIELD, accepts a code-word specifying the configuration of the well-field. Acceptable entries are:

SINGLE-WELL	A single well. May be used with one or several heat pumps of relatively low tonnage. Note that other heat pumps may be attached to other loops and other GROUND-LOOP-HXs.
LINE-2	2 wells in a line.
LINE-3	3 wells in a line.
LINE-4	4 wells in a line.
LINE-6	6 wells in a line.
LINE-8	8 wells in a line.
LINE-10	10 wells in a line.
TRIANGLE-3	3 wells arranged in a triangle.
SQUARE-2X2	4 wells arranged in a square.
RECTANGLE-3X2	6 wells in a 3x2 grid.
SQUARE-3X3	9 wells in a 3x3 grid.
RECTANGLE-5X3	15 wells in a 5x3 grid.
SQUARE-4X4	16 wells in a 4x4 grid.
RECTANGLE-4X3	12 wells in a 4x3 grid.
RECTANGLE-6X2	12 wells in a 6x2 grid.
RECTANGLE-8X2	16 wells in a 8x2 grid.
RECTANGLE-10X2	20 wells in a 10x2 grid.
RECTANGLE-6X3	18 wells in a 6x3 grid.
RECTANGLE-8X4	32 wells in an 8x4 grid.

For TYPE = VERT-WELL-NEW, accepts a code-word specifying the configuration of the well-field. Acceptable entries are:

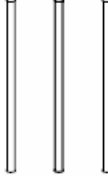
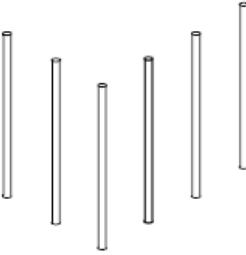
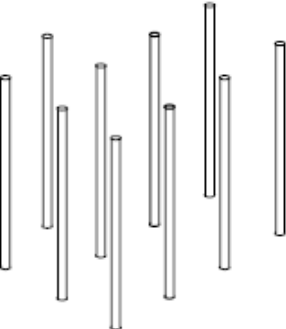
<u>Geometry & Illustration</u>	<u>Configuration</u>	<u># Bores</u>
<p>Single</p> 	<p>Single</p>	<p>1</p>
<p>Straight Line</p> 	<p>Line-Of-2 Line-Of-3 Line-Of-4 Line-Of-5 Line-Of-6 Line-Of-7 Line-Of-8 Line-Of-9 Line-Of-10</p>	<p>2 3 4 5 6 7 8 9 10</p>
<p>One L-shaped Line</p> 	<p>L-Config-2x2 L-Config-2x3 L-Config-2x4 L-Config-2x5</p>	<p>3 4 5 6</p>
<p>Two Parallel L-shaped Lines</p> 	<p>L2-Config-3x3 L2-Config-3x4 L2-Config-3x5</p>	<p>8 10 12</p>

<u>Geometry & Illustration</u>	<u>Configuration</u>	<u># Bores</u>
------------------------------------	----------------------	----------------

U-shaped Lines

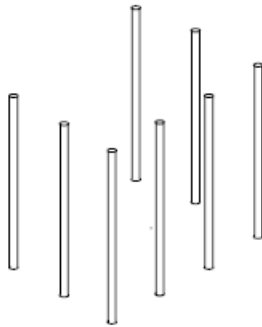

U-Config-3x2	5
U-Config-3x3	7
U-Config-3x4	9
U-Config-3x5	11

Open Rectangle

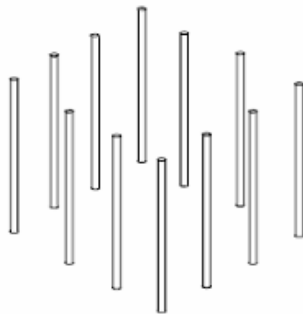

	8
	10
	12
Open-Rectangle-3x3	
Open-Rectangle-3x4	
Open-Rectangle-3x5	

Rectangle

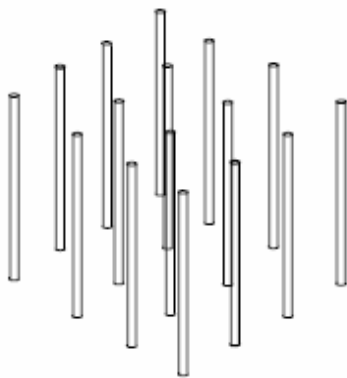

Rectangle-2x2	4
Rectangle-2x3	6
Rectangle-2x4	8
Rectangle-2x5	10
Rectangle-2x6	12
Rectangle-2x7	14
Rectangle-2x8	16
Rectangle-2x9	18
Rectangle-2x10	20
Rectangle-3x3	9
Rectangle-3x4	12
Rectangle-3x5	15
Rectangle-3x6	18
Rectangle-4x4	16
Rectangle-4x5	20
Rectangle-4x6	24
Rectangle-4x7	28
Rectangle-4x8	32

Custom-CM

Only used when the G-FUNCTION-FROM keyword is CUSTOM. Allows election from over 300 “custom” configurations created using GLHX G-Funtion software and made available via the LTS_gfnc.bin library. This library can only be obtained from ClimateMaster. This codeword value requires that the G-FUNCTION-NUM keyword be set equal the integer number of the G-Function that is desired to be retrieved from the library. See G-FUNCTION-NUM for more information on this library.

G-FUNCTION-FROM

Accepts a code-word that specifies the location of the G-Functions to be used for modeling this ground-loop heat exchanger. Used for TYPE = VERT-WELL-NEW only. Acceptable entries are:

LIBRARY	Specifies that one of the 43 G-functions found in the DOE-2.2 default library, as listed under the CONFIGURATION keyword, are to be used to model the well field..
CUSTOM	Specifies that G-functions are to be retrieved from the custom library (LTS_gfnc.bin) with the specific G-functions to be used specified via the G-FUNCTION-NUM keyword.

G-FUNCTION-NUM

Accepts a integer value that specifies the G-Functions number, from the LTS_gfnc.bin library, to be used for modeling this ground-source heat exchanger.. Used for TYPE = VERT-WELL-NEW only. Only used when the G-FUNCTION-FROM keyword is CUSTOM. This library is not part of the standard DOE-2.2 release; it is produced using the Earth Energy Designer (EED) borehole heat exchanger design software package . A DOE-2.2/eQUEST compatible version of this library, containing over 300 configurations, is available; information about this library can be obtained by contacting Xiaobing Liu at ClimateMaster (405) 745-6000 x335.

DEPTH

The distance between the ground surface and the bottom of the well. This is a required keyword.

SPACING

The distance between the centerlines of the wells. This is a required keyword.

BOREHOLE-DIAM

The diameter (in inches) of the borehole. Used for TYPE = VERT-WELL-NEW only.

FIELD-MULTIPLIER

The number of identical fields. The program assumes that these fields do not interact with each other.

Horizontal Well Systems

The following keywords specify the properties of the trench for a horizontal well.

CONFIGURATION

Accepts a code-word that specifies the configuration of the piping in the trench.

For TYPE = HORIZ-STRAIGHT-LOOP (Figure 35), allowed values are as follows:

HORIZ-U-TUBE	A single horizontal U-tube in a trench.
SINGLE-PIPE	A single pipe in a trench.
VERT-XO	Two-pipes in a trench, arranged vertically, with the flow in series.
VERT-XO-XO	Two sets of two-pipes in a trench, arranged vertically, with the flow of each set in series, and the flow between sets in parallel.
HORIZ-O-O	Two-pipes arranged horizontally in a trench, with the flow in parallel.
HORIZ-XO-XO	Two sets of pipes in a trench, with the pipes in each set arranged vertically with the flow in series, and the two sets arranged horizontally, with the flow between sets in parallel.

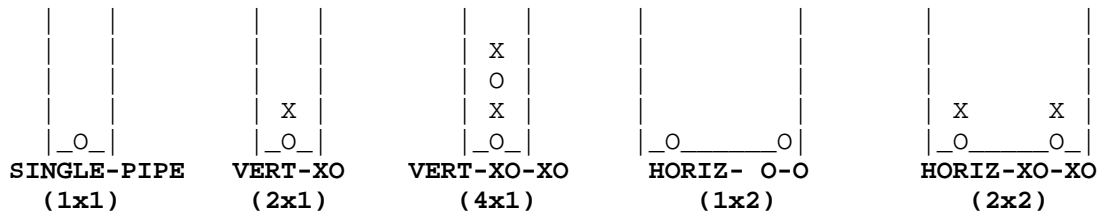

Figure 35 Pipe arrangements in horizontal wells
 (The diagram shows a trench cut vertically and viewed from the end)

For TYPE = HORIZ-SLINKY-LOOP, allowed values are:

- HORIZ-SLINKY A horizontal coil laid on the bottom of the trench.
- VERT-SLINKY A vertical coil laid against the side of the trench.

DEPTH

The distance between the ground surface and the bottom of the trench. This is a required keyword.

TRENCH-LENGTH

The length of the trench. This is a required keyword.

TRENCH-NUMBER

The number of identical trenches.

SPACING

The distance between trench centerlines. This is a required keyword.

PIPE-VERT-SEP

For TYPE = HORIZ-STRAIGHT-LOOP, the vertical distance between pipe centerlines, for pipes arranged vertically. This is a required keyword.

PIPE-HORIZ-SEP

For TYPE = HORIZ-STRAIGHT-LOOP, the horizontal distance between pipe centerlines, for pipes or sets of pipes arranged horizontally. This is a required keyword.

SLINKY-DIAMETER

For TYPE = HORIZ-SLINKY-LOOP, the diameter of the slinky coil. This is a required keyword.

SLINKY-PITCH

For TYPE = HORIZ-SLINKY-LOOP, specifies the pitch of the slinky coil. This is a required keyword.

Pipe Properties

The following keywords define the properties of the pipe.

PIPE-OUTSIDE-DIA

The outside diameter of the U-tube or pipe. Typical values for common pipe classifications are listed in the tables below. This is a required keyword.

PIPE-INSIDE-DIA

The inside diameter of the U-tube or pipe. Typical values for common pipe classifications are listed in the tables below. This is a required keyword.

Pipe Dimensions					
Pipe Size		Pressure Ratings			
		SDR 11		SDR 17	
Size (in)	Nom. OD (in)	ID (in)	Wall Thick. (in)	ID (in)	Wall Thick. (in)
3/4	1.05	0.859	0.095	0.926	0.062
1	1.315	1.076	0.120	1.160	0.077
1-1/4	1.66	1.358	0.151	1.465	0.098
1-1/2	1.9	1.555	0.173	1.676	0.112
2	2.375	1.943	0.216	2.096	0.140

Pipe Dimensions					
Pipe Size		Pressure Ratings			
		Schedule 40		Schedule 80	
Size (in)	Nom. OD (in)	ID (in)	Wall Thick. (in)	ID (in)	Wall Thick. (in)
3/4	1.05	0.824	0.113	0.742	0.154
1	1.315	1.049	0.133	0.957	0.179
1-1/4	1.66	1.38	0.14	1.278	0.191
1-1/2	1.9	1.61	0.145	1.5	0.2
2	2.375	2.067	0.154	1.939	0.218

U-TUBE-LEG-SEP

For TYPE = VERT-WELL-FIELD, the separation between the outer surfaces of the tubes. This is a required keyword.

PIPE-COND

The thermal conductivity of the pipe. Typical values for common pipe classifications are listed in the tables below. This is a required keyword.

Material	Thermal Conductivity Btu/hr-ft-F
Polyethylene	0.23
Polybutylene	0.13

Grout Properties

The following keywords define the properties of the grout (backfill) material.

GROUT-COND

The thermal conductivity (Btu/Hr-Ft-F) of the grout. Used for TYPE = VERT-WELL-NEW only. Typical values are listed in the table below.

Grouts without Additives		Thermally Enhanced Grouts	
Description	Conductivity Btu/hr-ft-F	Description	Conductivity Btu/hr-ft-F
Bentonite 10%, frozen	0.8	20% Bentonite -40% Quartzite	0.9
Bentonite 10%, in water	0.4	30% Bentonite -30% Quartzite	0.8
Bentonite 20%, in water	0.3	30% Bentonite -30% Iron Ore	0.5
Bentonite 40%, frozen	0.5	(Cement + Fly Ash + Sand)	1.1
Bentonite 40%, in water	0.3		
Bentonite, dry	0.1		
Clay, dry	0.2		
Clay, moist - wet	0.9		
Concrete	0.9		
Gravel, dry	0.2		
Gravel, saturated	1.0		
Sand, dry	0.2		
Sand, dry, compacted	0.7		
Sand, frozen	1.2		
Sand, moist	0.6		
Sand, saturated	1.4		
Silt, dry	0.2		
Silt, moist - wet	1.0		
Till	1.2		

The above data are compiled from following sources: Database of EED version 2.0 (Demo) (Hellstrom, et al 2000); Kavanaugh, Stephen and K. Rafferty, Ground-Source Heat Pumps, ASHRAE 1997.

Ground Properties

The following keywords define the properties of the ground.

REF-GRND-TEMP

The undisturbed mean ground temperature for horizontal loops; the undisturbed far-field ground temperature for vertical wells. For TYPE = VERT-WELL-NEW only, if this values is not specified it is calculated as the average annual outdoor dry bulb temperature using the weather file that is selected for the simulation.

REF-GRND-ADJ

The adjustment (in delta degrees F), for local conditions, to the undisturbed far-field ground temperature. Used for TYPE = VERT-WELL-NEW only.

GRND-DIFFUSIVITY

The ground thermal diffusivity. Typical values are found in the table below.

GRND-COND

The ground thermal conductivity. Typical values are found in the table below.

The data in the table below are compiled from following sources: Database of EED version 2.0 (Demo) (Hellstrom, et al 2000); Kavanaugh, Stephen and K. Rafferty, Ground-Source Heat Pumps, ASHRAE 1997; Soil and Rock Classification for the Design of Ground-Coupled Heat Pump Systems, IGSHPA 1989.

Description	Recommended		Description
	Conductivity Btu/hr-ft-F	Diffusivity Ft ² /hr	
Amphibolite	1.7	0.0432	Igneous or metamorphic rock composed largely or dominantly of amphibole minerals.
Andesite	1.3	0.0355	Extrusive usually dark grayish rock consisting essentially of oligoclase or feldspar.
Anhydrite	2.4	0.0794	Mineral consisting of an anhydrous calcium sulfate that is usually massive and white or slightly colored.
Aplite	1.8	0.0501	Fine-grained light-colored granite consisting almost entirely of quartz and feldspar.
Arkose	1.7	0.0562	Sandstone characterized by feldspar fragments that is derived from granite or gneiss which has disintegrated rapidly
Basalt	1.0	0.0274	Dark gray to black dense to fine-grained igneous rock that consists of basic plagioclase, augite, and usually magnetite.
Breccia	1.6	0.0517	Rock consisting of sharp fragments embedded in a fine-grained matrix (as sand or clay).
Clay, dry	0.2	0.0097	Earthy material that is plastic when moist but hard when fired, that is composed mainly of fine particles of hydrous aluminum silicates and other minerals.
Clay, moist - wet	0.9	0.0258	
Claystone	1.3	0.0371	
Coal	0.2	0.0065	Black or brownish black solid combustible substance formed by the partial decomposition of vegetable matter without free access of air and under the influence of moisture and often increased pressure and temperature that is widely used as a natural fuel.
Concrete	0.9	0.0344	Hard strong building material made by mixing a cementing material (as portland cement) and a mineral aggregate (as sand and gravel) with sufficient water to cause the cement to set and bind the entire mass
Conglomerate	1.6	0.0517	Rock composed of rounded fragments varying from small pebbles to large boulders in a cement (as of hardened clay).
Diorite	1.5	0.0347	Granular crystalline igneous rock commonly of acid plagioclase and hornblende, pyroxene, or biotite.
Dolomite	1.9	0.0496	Limestone or marble rich in magnesium carbonate.
Dunite	2.4	0.0561	A granitoid igneous rock consisting chiefly of olivine.
Eclogite	1.7	0.0363	Any member of metamorphic rocks whose original composition is similar to that of basalt.
Gabbro	1.1	0.0283	Granular igneous rock composed essentially of calcic plagioclase, a ferromagnesian mineral, and accessory minerals.
Gneiss	1.7	0.0535	Foliated metamorphic rock corresponding in composition to a feldspathic plutonic rock (as granite).
Granite	2.0	0.0549	Very hard natural igneous rock formation of visibly crystalline texture formed essentially of quartz and orthoclase or microcline.
Granodiorite	1.9	0.0492	Granular intrusive quartzose igneous rock intermediate between granite and quartz-containing diorite with plagioclase predominant over orthoclase.
Gravel, dry	0.2	0.0103	Loose rounded fragments of rock.
Gravel, saturated	1.0	0.0291	
Gypsum	0.9	0.0310	Widely distributed mineral consisting of hydrous calcium sulfate that is used especially as a soil amendment and in making plaster of paris.
Ignimbrite	1.7	0.0554	Hard rock formed by solidification of chiefly fine deposits of volcanic ash.
Limestone, marly	1.3	0.0371	Rock that is formed chiefly by accumulation of organic remains (as shells or coral), consists mainly of calcium carbonate, is extensively used in building, and yields lime when burned.
Limestone, massive	1.6	0.0472	
Limestone, oolitic	1.4	0.0404	

Description	Recommended		Description
	Conductivity Btu/hr-ft-F	Diffusivity Ft ² /hr	
Marble	1.5	0.0504	Limestone that is more or less crystallized by metamorphism, that ranges from granular to compact in texture, that is capable of taking a high polish, and that is used especially in architecture and sculpture.
Marl	1.2	0.0354	Loose or crumbling earthy deposit (as of sand, silt, or clay) that contains a substantial amount of calcium carbonate.
Marl, clayey/argillaceous	1.2	0.0352	
Marl, dolomitic	1.3	0.0371	
Peat	0.2	0.0070	Partially carbonized vegetable tissue formed by partial decomposition in water of various plants.
Pegmatite	1.7	0.0554	Coarse variety of granite occurring in dikes or veins.
Peridotite	2.3	0.0574	Any of a group of granitoid igneous rocks composed of ferromagnesian minerals and especially olivine.
Quartzite	3.5	0.1107	Compact granular rock composed of quartz and derived from sandstone by metamorphism.
Rhyolite	1.9	0.0609	Very acid volcanic rock that is the lava form of granite.
Rock Salt	3.1	0.1744	Crystalline compound NaCl that consists of sodium chloride.
Sand, dry	0.2	0.0111	Loose granular material that results from the disintegration of rocks, consists of particles smaller than gravel but coarser than silt.
Sand, dry compacted	0.7	0.0274	
Sand, frozen	1.2	0.0517	
Sand, moist	0.6	0.0215	
Sand, saturated	1.4	0.0372	
Sandstone	1.3	0.0446	Sedimentary rock consisting of usually quartz sand united by some cement (as silica or calcium carbonate).
Shale	1.2	0.0354	Fissile rock that is formed by the consolidation of clay, mud, or silt, has a finely stratified or laminated structure, and is composed of minerals essentially unaltered since deposition.
Schist	1.8		Metamorphic crystalline rock that has a closely foliated structure and can be split along approximately parallel planes.
Silt, dry	0.2	0.0097	Loose sedimentary material with rock particles usually 1/20 millimeter or less in diameter.
Silt, moist - wet	1.0	0.0317	
Siltstone	1.4	0.0404	Rock composed chiefly of indurated silt
Slate	1.2		Dense fine-grained metamorphic rock produced by the compression of various sediments (as clay or shale) so as to develop a characteristic cleavage.
Syenite	1.5	0.0420	Igneous rock composed chiefly of feldspar.
Till (boulder clay, moraine)	1.2	0.0369	Unstratified glacial drift consisting of clay, sand, gravel, and boulders intermingled.
Tonalite	1.6	0.0436	
Trachyte	1.6	0.0517	Usually light-colored volcanic rock consisting chiefly of potash feldspar.
Tuff	0.6	0.0388	Rock composed of the finer kinds of volcanic detritus usually fused together by heat.

GRND-YEAR-SWING

For horizontal loops only, the annual ground surface temperature swing. This is a required keyword.

GRND-PHASE-CONST

For horizontal loops only, the phase lag (in days) in the ground temperature swing.

Fluid Properties

The following keywords define the properties of the fluid used in the GLHX pipe circuit..

FLUID

Accepts a code-word that specifies the fluid used in the circulation loop of this ground-loop heat exchanger. Used for TYPE = VERT-WELL-NEW only. Acceptable entries are:

WATER	The default..
PROPYLENE-GLYCOL	aqueous solutions of Propylene Glycol
ETHANOL	aqueous solutions of Ethylene Glycol
ETHYLENE-GLYCOL	aqueous solutions of Methanol.
METHANOL	aqueous solutions of Ethanol

ANTI-FREEZE-CONC

The concentration (in percent) of the anti-freeze fluid, as specified using the FLUID keyword, and water. Used for TYPE = VERT-WELL-NEW only.

Loop History

The following keywords define the history of the loop so that the calculation can predict the ground field's performance in this year's simulation.

NUM-OF-YEARS

The number of years of operation previous to the simulation year. A value of zero means that this year's analysis is the first year after the system was installed.

DESIGN-HEAT-DAY

The Julian day of the year that the heating design day occurs.

DESIGN-COOL-DAY

The Julian day of the year that the cooling design day occurs.

DESIGN-HEAT-LOAD

Takes a list of 24 values of the hourly heat exchange between loop and ground on the heating design day. A positive value means that heat flows from loop to ground. A negative number means that heat flows from ground to loop.

DESIGN-COOL-LOAD

Takes a list of 24 values of the hourly heat exchange between loop and ground on the cooling design day. A positive value means that heat flows from loop to ground. A negative number means that heat flows from ground to loop.

Attachment to a CIRCULATION-LOOP

The following keywords define the attachment between the GROUND-LOOP-HX and the CIRCULATION-LOOP. Note that you can define more than one GROUND-LOOP-HX and these heat-exchangers can be attached to the same or different CIRCULATION-LOOPS.

CIRCULATION-LOOP

Takes the U-name of a CIRCULATION-LOOP of TYPE = WLHP or CW to which the heat-exchanger is attached.

CAPACITY

The rated capacity of the heat-exchanger. The program uses this value to calculate the design flow rate through the ground loop. This flow rate is then used hourly to adjust the pressure drop through the ground loop. If you don't specify this keyword the capacity will default to the loop capacity adjusted by the CAPACITY-RATIO. If no CAPACITY-RATIO is input the capacity will default to the loop capacity divided by the number of heat-exchangers attached to the loop.

CAPACITY-RATIO

When CAPACITY is not specified, this is the fraction of the design loop capacity that this heat-exchanger will be sized to meet. Normally, you should allow this variable to default to 1.0.

HX-PUMP

Takes the U-name of a PUMP that circulates fluid through the ground loop. If you do not specify a pump the head loss of the ground loop will be passed onto the pump attached to the parent CIRCULATION-LOOP.

HX-DT

The design temperature change of the fluid circulating through the ground loop. The default is the LOOP-DESIGN-DT of the attached CIRCULATION-LOOP. The program uses this keyword to determine the design flow of the heat-exchanger, and in turn to size the equipment-recirculation pump, if any, on the ground loop and calculation the hourly pressure drop. If no equipment-recirculation pump exists, then the flow through the ground loop is based on the LOOP-DESIGN-DT.

HX-HEAD

The head loss through the ground loop piping at design flow.

HX-STATIC-HEAD

The static head of the ground loop (non-varying with flow). This value should be allowed to default to 0.0

HX-FLOW-CTRL

Takes a code-word that specifies the type of flow through the ground loop.

CONSTANT-FLOW	Indicates that the ground loop flow is independent of the CIRCULATION-LOOP flow. Unless an HX-PUMP exists the the ground loop flow will depend on the primary loop flow. Thus, if the flow in the primary loop is variable, then the flow through the ground loop will also be variable.
VARIABLE-FLOW	Indicates that the ground loop flow varies as required to meet the CIRCULATION-LOOP temperature setpoint.

HX-MIN-FLOW

When HX-FLOW-CTRL = VARIABLE-FLOW, this is the minimum allowable fraction of the design flow through the ground loop.

HX-MAX-FLOW

The ratio of the maximum allowable flow ratio to the design flow ratio.

Application to a Single Heat Pump

When simulating systems that have a single heat-pump unit, it is usually the case that the ground loop pump will cycle with the compressor in the heat pump. To simulate this case, set the SYSTEM:CW-VALVE = YES for the

heat pump. To simulate a cycling pump, set the CIRCULATION-LOOP:LOOP-OPERATION = SUBHOUR-DEMAND.

Integration with a Cooling Tower

The program can simulate GROUND-LOOP-HXs together with cooling towers. Often, it may not be economical to size the well field large enough to handle the peak cooling loads, especially for buildings that are cooling-dominated. In this case, it may be desirable to install a fluid cooler in parallel with the well field. A common control strategy would be to allocate as much of the flow to the well field as can be cooled to the loop setpoint, and pass the rest of the flow to the fluid cooler.

Note that ground-loop heat-exchangers can be integrated with heat-rejection devices only; they cannot be satisfactorily integrated with boilers; the program will issue an error to flag this situation.

You must use an EQUIP-CTRL sequence to coordinate a ground-loop heat-exchanger with a cooling tower. In the EQUIP-CTRL section, refer to the sub-section titled *Ground-Loop Heat-Exchangers and Fluid Coolers in parallel on WLHP loops* for more information and an example.

Error Checking

The following checks are made at run time.

TRENCH-DEPTH must be at least 1 ft (0.3 m) for horizontal loops.

(TRENCH-DEPTH) - (PIPE-VERT-SEP) must be at least 1 ft (0.3 m) for horizontal loop SINGLE-PIPE and HORIZ-O-O configurations.

(TRENCH-DEPTH) - 3 x (PIPE-VERT-SEP) must be at least 1 ft (0.3 m) for the horizontal loop VERT-XO configuration.

When NUM-OF-TRENCHES is greater than 1:

TRENCH-SPACING must be at least 1 ft for the horizontal loop configuration VERT-XO;

(TRENCH-SPACING) - (PIPE-HORIZ-SEP) must be at least 1 ft for horizontal loop VERT-XO-XO, HORIZ-O-O, HORIZ-XO-XO and HORIZ-SLINKY configurations.

Example input: Pump cycles with compressor (1 unit)

```

CYCLING-PUMP = CURVE-FIT
  TYPE                = LINEAR
  OUTPUT-MIN          = 0.02
  OUTPUT-MAX          = 1.0
  DATA                = (0,1) (0.02,1.0) ..

GLHX-PUMP = PUMP
  PUMP-HP-FFLOW        = CYCLING-PUMP ..

GLHX-LOOP = CIRCULATION-LOOP
  TYPE                = WLHP
  LOOP-OPERATION      = DEMAND
  LOOP-PUMP            = GLHX-PUMP
  MAX-ALARM-T         = 120.  $ Make sure heat-pump performance
    
```

```

MIN-ALARM-T      = 30.  $ curves valid for these extremes
.....

GROUND-HX-1 = GROUND-LOOP-HX          $ More than one can
TYPE           = HORIZ-SLINKY-LOOP   $ be defined and
CONFIGURATION  = HORIZ-SLINKY        $ attached to
DEPTH          = 8.                   $ different loops
SPACING        = 20.0
TRENCH-LENGTH = 100.0
PIPE-OUTSIDE-DIA = 1.5
PIPE-INSIDE-DIA = 1.3
PIPE-COND      = 0.9
TRENCH-NUMBER  = 2.0
GRND-YEAR-SWING = 10.0
SLINKY-DIAMETER = 3.0
SLINKY-PITCH   = 2.0
NUM-OF-YEARS   = 10.0
CIRCULATION-LOOP = GLHX-LOOP ..

$ Curves for a ground source heat pump unit

SDL-C5new = CURVE-FIT
TYPE      = BI-QUADRATIC          $ COOL-CAP-FT
COEF      = (-.4462908,.0262524, 0,
             .0013804,          0,-.0000812) ..

SDL-C15new = CURVE-FIT
TYPE      = BI-QUADRATIC          $COOL-EIR-FT
COEF      = (4.412744, -0.055, 0,
             -0.0052205,.000113718, 0) ..

SDL-C20new = CURVE-FIT
TYPE      = QUADRATIC             $COOL-EIR-FPLR
COEF      = (0.009085, 1.34384, -0.352925) ..

SDL-C25new = CURVE-FIT
TYPE      = BI-QUADRATIC          $ COOL-SH-FT
COEF      = (.3923053,.01188804,0,
             -.00080916,0,-.00002452) ..

SDL-C55new = CURVE-FIT
TYPE      = BI-QUADRATIC          $ HEAT-CAP-FT
COEF      = (.59048,-.001464,0,
             .01936,0,-.000048) ..

SDL-C60new = CURVE-FIT
TYPE      = BI-QUADRATIC          $HEAT-CAP-EIR
COEF      = (1.06377143, 0.0060479, 0,
             -0.0187978, 0.0001117238,0)

SDL-C65new = CURVE-FIT
TYPE      = QUADRATIC             $COOL-EIR-FPLR
COEF      = (0.009085, 1.34384, -0.352925) ..

SYS-1 =SYSTEM
TYPE   = HP
    
```

```

.....
CW-LOOP           = GLHX-LOOP
CW-VALVE          = YES           $ variable flow
SUPPLY-KW/FLOW    = .00015        $ Select appropriate
COOLING-EIR       = 0.213313      $ values for your
HEATING-EIR       = 0.271003      $ equipment.
COOL-CAP-FT       = SDL-C5new
COOL-SH-FT        = SDL-C25new
COOL-EIR-FT       = SDL-C15new
COOL-EIR-FPLR     = SDL-C20new
HEAT-CAP-FT       = SDL-C55new
HEAT-EIR-FT       = SDL-C60new
HEAT-EIR-FPLR     = SDL-C65new ..

$ Hourly report

HR-DAY-ON = DAY-SCHEDULE
TYPE      = ON/OFF
(1,24) (1.) ..

HR-WK-ON = WEEK-SCHEDULE
(ALL) HR-DAY-ON ..

HR-DAY-OFF = DAY-SCHEDULE
TYPE      = ON/OFF
(1,24) (0.) ..

HR-WK-OFF = WEEK-SCHEDULE
(ALL) HR-DAY-OFF ..

HR-SCH = SCHEDULE
TYPE = ON/OFF
THRU FEB 8 HR-WK-OFF
THRU MAR 9 HR-WK-ON
THRU JUN 7 HR-WK-OFF
THRU JUL 13 HR-WK-ON
THRU DEC 31 HR-WK-OFF ..

RB-GLHX-LOOP = REPORT-BLOCK
VARIABLE-TYPE = GLHX-LOOP
VARIABLE-LIST = (5,15,3) ..

RB-GROUND =REPORT-BLOCK          VARIABLE-TYPE = GROUND-HX-1
VARIABLE-LIST =
(1,2,3,4,5,6,7,8,9) ..

HW-REPORT1 =HOURLY-REPORT      R-SCH = HR-SCH
GROUND) ..                    REPORT-BLOCK = (RB-GLHX-LOOP,RB-

```

HEAT-EXCHANGER

Defines the operating parameters of a heat-exchanger. Heat-exchangers are used to:

Isolate a cooling tower from a condenser loop or water-loop heat-pump system (TYPE =OPEN-TWR&HX in the HEAT-REJECTION command).

Model the performance of dry coolers (TYPE =DRYCOOLER in the HEAT-REJECTION command).

Model the performance of fluid coolers when running dry (TYPE=FLUID-COOLER in the HEAT-REJECTION command).

The program simulates a variety of heat-exchanger types (air-to-air, water-to-water, etc.) and configurations (parallel flow, counter flow, etc.). An NTU/effectiveness approach is used to solve the heat transfer equations. The overall heat transfer coefficient is adjusted hourly as a function of the supply-side and demand-side flows and film coefficients. Compared to a model that uses a fixed UA product, this approach allows better simulation of performance at low flow rates.

TYPE

Accepts a code-word that specifies the type of heat-exchanger. This is a required keyword that should be entered first. Allowed values are:

AIR-TO-AIR	Air is the fluid on both the supply side and demand side of the heat-exchanger.
WATER-TO-AIR	Water is the fluid on the supply side and air is the fluid on the demand side of the heat-exchanger.
AIR-TO-WATER	Air is the fluid on the supply side and water is the fluid on the demand side of the heat-exchanger.
WATER-TO-WATER	Water is the fluid on both the supply side and demand side of the heat-exchanger.

CONFIGURATION

Accepts a code-word that specifies the configuration of the heat-exchanger. The default varies by TYPE. Allowed values are:

COUNTERFLOW	The fluids enter at opposite ends and flow counter to each other. This is the default for AIR-TO-WATER and WATER-TO-WATER heat-exchangers.
PARALLELFLOW	The fluids enter at the same end and flow in parallel.
CROSSFLOW	The fluids enter crossways to each other and flow at right angles to each other. This is the default for AIR-TO-AIR heat-exchangers.
CROSSFLOW-MIXED	Same as CROSSFLOW, but both streams are fully mixed.
CROSSFLOW-SUP-MIXED	Same as CROSSFLOW, but the supply-side flow is mixed and the demand-side flow is unmixed. This is the default for WATER-TO-AIR heat-exchangers.
CROSSFLOW-DEM-MIXED	Same as CROSSFLOW, but the supply-side flow is unmixed and the demand-side flow is mixed.

PARALLEL-COUNTERFLOW-12 A 1,2-parallel-counterflow heat-exchanger.

CAPACITY

The capacity of the heat-exchanger at design values of supply flow, demand flow and inlet temperature difference. The default value depends on the application.

UA-PRODUCT

The overall heat transfer coefficient of the heat-exchanger at the design values of capacity, supply flow, demand flow and inlet temperature difference. If you don't specify this keyword, the program will calculate its value based on TYPE, CONFIGURATION, CAPACITY, SUPPLY-FLOW, DEMAND-FLOW and INLETS-DT.

INLETS-DT

The design temperature difference between the supply-side fluid temperature entering the heat-exchanger, and the demand-side fluid temperature entering the heat-exchanger. The default value depends on the application; it is based on the design criteria for the loops, cooling towers, etc. that are coupled through the heat-exchanger.

SUPPLY-FLOW

The supply-side design fluid flow rate. The default depends on the application and the design criteria for the supply-side fluid.

MAX-SUPPLY-FLOW

The ratio of the maximum supply-side flow rate to the design flow rate. Some applications will limit the flow rate by this value. For example, the default MAX-SUPPLY-FLOW for a heat-exchanger coupling a cooling tower to a condenser loop is 1.1. When determining the flow cooling capacity of the heat-exchanger in the load allocation routines, the predicted flow will not be allowed to exceed this value.

SUPPLY-PRES-DROP

The pressure drop of the supply-side fluid at the design SUPPLY-FLOW. This keyword is currently unused, but may be used in the future in the library entries for heating coils, etc.

SUPPLY-FILM-RES

The fraction of the overall heat-exchanger resistance (where resistance = [UA-PRODUCT]⁻¹) due to the supply-side film resistance. The default value varies by TYPE. The program uses this value to determine the design supply-side film resistance. The program uses the following equation to modify this design value on an hourly basis to account for the change in UA-PRODUCT due to variations in supply flow:

$$RSUP = RSUP-DESIGN * (Flow/[SUPPLY-FLOW])**[SUPPLY-FILM-EXP]$$

The default values are only approximate. You should verify the relative fractions of the supply-side and demand-side film resistances if off-design performance is of critical importance in your analysis.

The design resistance fractions of the supply-side, demand-side, and the heat-exchanger resistances must add up to 1.0. Therefore, the sum of the supply-side and demand-side film resistance fractions must be less than or equal to 1.0. The program checks for this condition and will give an error message if your input does not meet this criterion.

SUPPLY-FILM-EXP

The exponent used to modify SUPPLY-FILM-RES as a function of the hourly fluid flow. The default for water is 0.8, which corresponds to turbulent flow in a tube. The default for air is 0.52, which corresponds to air flowing over a finned surface.

The program assumes that this exponent is valid over the entire flow range. If the flow (and Reynolds number) drops low enough, the flow will transition from turbulent to laminar, and this assumption will not be valid. For most

applications, this transition will normally not occur until the flow is in the 25% range or lower. The errors generated will be small and should have a negligible impact on energy consumption.

DEMAND-FLOW

Like SUPPLY-FLOW, but on the demand side of the heat-exchanger.

DEMAND-PRES-DROP

Like SUPPLY-PRES-DROP, but on the demand side of the heat-exchanger.

DEMAND-FILM-RES

Like SUPPLY-FILM-RES, but on the demand side of the heat-exchanger.

DEMAND-FILM-EXP

Like SUPPLY-FILM-EXP, but on the demand side of the heat-exchanger.

MAX-ERROR

The maximum convergence error that the iterative solution must meet. The NTU/effectiveness approach allows some variables to be solved directly without iteration. Other variables can be solved only by using an iterative approach. The default value is 0.005, which means that the algorithm will iterate until it has found a solution that is within 0.5% of the true value.

Ideally, this keyword should have as large a value as possible without generating significant simulation errors. Values smaller than the default may give slightly more accurate results but may increase the program run time significantly.

EQUIPMENT-REPORT

Not currently used.

HEAT-REJECTION

Defines the operating parameters of heat-rejection devices such as cooling towers, fluid coolers, and dry coolers. A HEAT-REJECTION device may be attached to a CIRCULATION-LOOP of TYPE = CW or WLHP.

Cooling towers may be directly attached to a loop (open tower), or may include an intermediate heat-exchanger. The algorithms model the performance of a tower for wet-bulbs ranging from 20F to 82F (6.6C to 27.8C), leaving temperatures from 40F to 95F (4.4C to 35C), and temperature drops from 1F to 20F (0.55K to 11.1K). For this range of conditions, the algorithms will predict the leaving tower temperature with an error of less than 1F (0.55K) for most common operating conditions, and a maximum error of 2F (1.1K) for the more extreme conditions (very large or very small temperature drops, and very close approaches to the wet-bulb).

U-name is mandatory. It will be used in the heading of the equipment report to identify the device.

Example input:

```
"Cooling Tower 1" = HEAT-REJECTION
  TYPE              = OPEN-TWR
  CW-LOOP           = "Condenser Loop" ..
```

TYPE

Accepts a code-word that specifies the type of heat-rejection device. This keyword is required and should be the first entered. Allowed values are:

- | | |
|--------------|---|
| OPEN-TWR | A cooling tower that directly exposes the fluid in the condenser loop to the air flowing through the tower. This type of tower is commonly used with chillers or other devices having cleanable condensers. It is not normally used with devices such as water-loop heat pumps where the oxygen and other contaminants introduced into the loop from the tower's air flow is unacceptable.

The default data is based on a cross-flow configuration, with an induced draft propeller discharging at the top of the tower. This is typically the most energy-efficient configuration. Other configurations may be fetched from the library (if available), or created using the keywords associated with this component. |
| OPEN-TWR&HX | An open cross-flow tower identical to OPEN-TWR, but incorporating a plate and frame heat-exchanger to isolate the condenser fluid from the tower fluid. A pump separate from the CIRCULATION-LOOP's pump circulates fluid between the tower and the heat-exchanger. See "Performance of Open Tower with Heat-exchanger," below, for information on the keywords defining the heat-exchanger. |
| FLUID-COOLER | A fluid cooler. This component isolates the condenser water from the air flow via a heat-exchanger incorporated within the cooler itself. A fan blows air through one side of the heat-exchanger while a spray pump simultaneously sprays water into the air. Condenser fluid circulates through the other side of the heat-exchanger.

While a fluid cooler has a spray pump, you cannot specify the pump separately as with the OPEN-TWR&HX. The pump is integral to the unit, and consumes a constant amount of power whenever the fluid cooler is operating. |

The default performance for a fluid cooler is based on a unit having a blow-through centrifugal fan. An axial fan unit can be simulated by reducing the ELEC-INPUT-RATIO by approximately half.

A fluid cooler will commonly require freeze protection when operated during the winter months. The sections on pan losses, dry coil operation, and coil losses discuss freeze protection in detail.

DRYCOOLER

A dry cooler. A dry cooler is simply an air-cooled coil and fan used for heat rejection. A common example of an HVAC application for a drycooler is a water-cooled direct-expansion computer room cooling unit. The self-contained unit is located in the space it serves, and rejects its heat to a condenser water loop. The loop in turn rejects its heat to the outdoors via one or more dry coolers.

Dry coolers can also be used for rejecting the jacket heat from an engine generator.

Number of Cells and Cell Control

The following keywords specify the number of independently controlled cells in the heat-rejection device (each cell having its own fan), and how the cells are controlled.

NUMBER-OF-CELLS

The total number of independently controlled cells in the component. If not entered, the program will determine the number of cells required based on a maximum load of 15 MBtu/hr (4.40 MW) per cell for cooling towers, 8 MBtu/hr (2.34 MW) per cell for fluid coolers, and 120 KBtu/hr (35.2 kW) per cell for dry coolers. The capacity per cell is then the CAPACITY divided by the NUMBER-OF-CELLS.

CELL-CTRL

In multiple-cell units, takes a code-word that specifies whether the controls attempt to operate only the number of cells needed to meet the load, or operate as many cells as possible. Options are:

MIN-CELLS	Indicates that only the actual number of cells needed will be used. All other cells will be shut down with no water flow. If the component is controlling to a fixed setpoint, the flow capacity per cell will increase as the dry-bulb or wet-bulb temperature drops. The program will attempt to use as few cells as possible to cool the fluid. In no case, however, will the flow per cell be allowed to exceed MAX-FLOW/CELL.
MAX-CELLS	Indicates that as many cells as possible will be turned on. In no case, however, will the flow per cell be allowed to drop below MIN-FLOW/CELL, unless the circulation loop flow is so low that only one cell can operate.

Using MAX-CELLS will enhance the energy savings associated with two-speed or variable-speed fans, and is strongly recommended.

MAX-FLOW/CELL

The largest allowable ratio of actual fluid flow rate to nominal fluid flow rate. For cooling towers and fluid coolers, the nominal flow rate is determined at the Cooling Tower Institute (CTI) conditions.

MIN-FLOW/CELL

The smallest allowable fraction of the nominal flow rate for which the unit is still rated. Flows smaller than this value will commonly result in fluid distribution problems; the pressure at each nozzle will be too weak for the fluid to be sprayed out in the correct pattern.

Fan Power Consumption and Control

The next set of keywords specifies the power consumption of the fans, and how the fans are controlled to modulate the unit capacity and leaving temperature. Note that the leaving temperature setpoint of the unit is determined by the controls of the CIRCULATION-LOOP to which the heat rejection device is attached.

FAN-KW/CELL

The fan power per cell. If not specified, this value will be calculated using ELEC-INPUT-RATIO.

ELEC-INPUT-RATIO

The ratio of electric input to nominal capacity for the cell fan expressed as

$$(\text{fan electric power}) / (\text{cell capacity})$$

where "cell capacity" is the heat rejection capacity of the cell (see CAPACITY keyword, below) and where "fan electric power" and "cell capacity" are expressed in the same units. The program ignores ELEC-INPUT-RATIO if FAN-KW/CELL is specified.

The default ELEC-INPUT-RATIO for open towers is 0.0105, which corresponds to approximately 0.0154 hp/gpm (0.0030 kW/(l/min)) at the CTI rating conditions. For a fluid cooler, the default EIR is substantially higher, 0.054. This value is representative of a fluid cooler having a centrifugal fan. To simulate an axial fan, you can cut this value in half.

CAPACITY-CTRL

Takes a code-word that indicates the control method for regulating the fluid exit temperature. Options are:

ONE-SPEED-FAN	A one-speed fan cycles on and off to maintain the tower setpoint. The program assumes that the fan can cycle as often as required to maintain the setpoint. In actual practice, fan cycling is usually limited to no more than 4-8 cycles per hour to protect the motor against burnout. This can cause wide fluctuations in the condenser loop temperature, which the program does not model.
FLUID-BYPASS	A three-way valve bypasses water around the heat rejection device. The valve modulates to maintain the exit setpoint. The fan runs continuously during all hours that a heat rejection load exists.
DISCHARGE-DAMPER	A discharge damper modulates the fan airflow and rejection capacity. Power consumption is approximately linear down to 50% airflow, but then flattens out and remains relatively constant at lower air flows. The program calculates power consumption at reduced air flows using the FAN-KW-FDAMPER curve.
TWO-SPEED-FAN	The fan cycles between off, low speed and high speed to maintain the fluid setpoint.
VARIABLE-SPEED-FAN	The air flow is modulated so that the rejection capacity exactly matches the load at the desired setpoint. This code-word simulates both variable speed drives as well

as variable pitch fans. Power consumption at reduced air flows is calculated using the FAN-KW-FSPEED curve.

FAN-KW-FSPEED

Takes the U-name of a cubic curve that expresses the fan horsepower as a function of fan speed. The output of this curve is the fraction of the full air flow horsepower used at the current fan speed.

FAN-KW-FDAMPER

Takes the U-name of a cubic curve that expresses the fan horsepower as a function of fan air flow when a fan discharge damper modulates the air flow. The output of this curve is the fraction of the full air flow horsepower used at the current fan speed.

FAN-OFF-AIRFLOW

The ratio of the air flow through the unit when the fans are off (i.e., flow due to natural convection) to the air flow at high speed. This value is used in the CAP-FAIRFLOW curve to determine the unit capacity when the fan has cycled off but fluid is still flowing through the cells.

FAN-LOW-AIRFLOW

The ratio of air flow through the unit when the fans are at low speed to the air flow at high speed. Used only when CAPACITY-CTRL = TWO-SPEED. This value is used in the CAP-FAIRFLOW curve to determine the capacity of the tower when the fan is operating at low speed.

FAN-LOW-KW

The ratio of the power consumed by the fan at low speed to the power consumed at high speed. Used only when the CAPACITY-CTRL = TWO-SPEED. If not specified, the program will calculate this value by using the FAN-LOW-AIRFLOW value in the FAN-KW-FSPEED curve.

MIN-VFD-SPEED

When a variable-speed fan is used, this is the minimum fraction of nominal fan speed at which the fan can operate. If the load is such that the component will overcool the fluid at this minimum speed, then the fan will cycle between off and minimum speed.

It is possible that the fan may reach a "critical speed" as the air flow is reduced. The value of MIN-VFD-SPEED should be above this value; otherwise, excessive vibration may damage the unit. For specific applications, you should consult with the unit's manufacturer.

MIN-RESET-PLR

The part load ratio at which the fan operates at MIN-VFD-SPEED when using the COOL-SETPT-CTRL = LOAD-RESET control strategy in the CIRCULATION-LOOP.

MAX-RESET-SPEED

When a variable-speed fan is used, this is the maximum fraction of nominal fan speed at which the fan operates when using the COOL-SETPT-CTRL = LOAD-RESET control strategy in the CIRCULATION-LOOP.

Attachment to a CW or WLHP Loop

The next set of keywords specifies the CIRCULATION-LOOP that is attached to the tower, and any condenser pumps dedicated to this tower.

CW-LOOP

Takes the U-name of the CW or WLHP loop to which this unit is attached.

CW-PUMP

Takes the U-Name of a PUMP directly attached to the tower. This pump is always an equipment-recirculation pump; it never powers the loop.

Note that an OPEN-TWR&HX tower must have a CW-PUMP since the heat-exchanger isolates the tower from the CIRCULATION-LOOP. If you do not specify this pump, then the program will create a pump. The other tower types do not need a CW-PUMP, as the loop pumps will normally move the water through the tower.

For a fluid cooler, this keyword defines a pump that acts on the loop fluid in a manner identical to an OPEN-TWR. You specify the spray pump using the HEAT-REJECTION keywords SPRAY-KW/CELL, SPRAY-KW/FLOW and SPRAY-PUMP-CTRL.

CW-DT

The design temperature change of the condenser water through the tower. The default is the LOOP-DESIGN-DT of the CW loop. The program uses this keyword to determine the design flow through the tower, and in turn size the equipment-recirculation pump, if any, on the tower, and calculate the hourly pressure drop. If no equipment-recirculation pump exists, then the flow through the tower is based on the LOOP-DESIGN-DT.

CW-HEAD

The condenser water head loss through the tower at design flow. Includes the effect of piping, spray nozzles, etc.

CW-STATIC-HEAD

The static (non-varying) head of the unit. For OPEN-TWRs, the static head is the difference in height between the spray nozzles and the fluid surface in the pan. This is also true for OPEN-TWR&HX. For other types, the static head is normally zero.

CW-FLOW-CTRL

Accepts a code-word that specifies the flow control mechanism for the pump when a CW-PUMP is defined and is a equipment-recirculation pump (the loop is powered by other pumps). Allowed values are:

CONSTANT-FLOW The flow through the tower is independent of the loop flow.

VARIABLE-FLOW The flow through the tower is the same as the loop flow.

CW-MIN-FLOW

The minimum allowable fraction of design condenser water flow when a CW-PUMP is defined and it is a variable-flow equipment-recirculation pump.

AUX-KW

Auxiliary electrical consumption. For a tower having a filtration system, AUX-KW can represent the power consumption of the filter pump. If the filter runs only when the tower is running, then AUX-MODE should be set to WHEN-ON.

AUX-MODE

Accepts a code-word that specifies when the AUX-KW is consumed.

ALWAYS Auxiliary power is consumed all hours.

WHEN-ON Auxiliary power is consumed only during the hours the tower is operating.

WHEN-OFF Auxiliary power is consumed only during the hours the tower is off.

SCHEDULED The power consumption is scheduled (see AUX-SCH).

AUX-SCHEDULE

When AUX-MODE = SCHEDULED, takes the U-name of a schedule of TYPE = MULTIPLIER that varies the AUX-KW on an hourly basis.

AUX-METER

Takes the U-name of the AUX-METER to which the auxiliary electricity consumption of the tower is assigned. This keyword defaults to the same meter as the component's ELEC-METER.

ELEC-METER

Takes the U-name of the ELEC-METER to which the electricity consumption of the tower is assigned. The default is the MSTER-METER: HTREJ-ELEC-METER.

EQUIPMENT-REPORTS

Takes the code-words YES or NO. When report PS-H of the PLANT-REPORTS is enabled, a report will print for the tower unless this keyword is set to NO.

OPEN-TWR, OPEN-TWR&HX and FLUID-COOLER

For open cooling towers and fluid coolers, the following set of keywords defines the unit capacity and how the capacity varies with load, ambient conditions, and loop temperature setpoint. Cooling towers and fluid coolers differ from other types of primary equipment in that manufacturers commonly rate their equipment in terms of how much water the unit can cool (gpm or l/min) rather than the actual heat rejection capacity (Btu/hr or W), although the two are equivalent. The program compromises between the two approaches. If you specify a capacity, it is in Btu/hr or W. The design routine then calculates the fluid flow rate that corresponds to this capacity at your design conditions, and determines the equivalent size tower normalized to the CTI design condition. This condition is 95F (35C) tower water entering temperature and 85F (29.4C) tower water leaving temperature when the wet-bulb is 78F (25.6C). This corresponds to a range of 10F (5.6K) and an approach of 7F (3.9K).

CAPACITY

The size of the heat-rejection device. If you do not specify this keyword, the capacity will default to the loop capacity, adjusted by the CAPACITY-RATIO. If no CAPACITY-RATIO is input, then the capacity will default to the loop capacity divided by the number of heat-rejection devices attached to the loop.

CAPACITY-RATIO

If CAPACITY is not specified, this is the fraction of the design loop capacity that this component will be sized to meet. If you are defining two components of identical size that should just meet the design loop load, then CAPACITY-RATIO should be set to 0.5 for each component. If you want to include a 20% safety factor in each component, then set the CAPACITY-RATIO of each component to 0.6.

If you don't specify CAPACITY or CAPACITY-RATIO, then the capacity will default to the loop capacity divided by the number of heat-rejection devices attached to the loop.

DESIGN-WETBULB

The wet-bulb temperature used in the cooling tower design calculations. The default (78F or 25.6C) corresponds to the point at which towers are rated by CTI. Specifying a lower design wet-bulb when other conditions are fixed (including design approach) will cause the program to size a larger tower (in terms of flow capacity at CTI conditions, not heat rejection capacity). Energy consumption may then either increase or decrease depending on CAPACITY-CTRL and the temperature setpoint.

DESIGN-APPROACH

The approach (difference between tower water leaving temperature and wet-bulb) used in the cooling tower design calculations. The default (7F or 3.9K) corresponds to the CTI rating point (95F (35C) tower water entering temperature and 85F (29.4C) tower water leaving temperature when the wet-bulb is 78F (25.6C)). Specifying a higher approach when other conditions are fixed (including design wet-bulb) will cause the program to size a smaller tower (in terms of flow capacity at CTI conditions, not heat rejection capacity). Energy consumption may then either increase or decrease depending on CAPACITY-CTRL and the temperature setpoint.

DESIGN-RANGE

The temperature drop through the tower used to calculate the water flow rate corresponding to the CAPACITY value. The default is determined as described under the CW-DT keyword.

Normally, you should let this value default. The only time you should change it is for an OPEN-TWR&HX having dissimilar flows on each side of the heat-exchanger. In this case, DESIGN-RANGE applies to the tower side of the heat-exchanger, and CW-DT applies to the condenser side (circulation loop side) of the heat-exchanger.

CAP-FAPP&WB

Takes the U-name of a bi-quadratic curve that adjusts the flow capacity as a function of the approach and wet-bulb. The program calculates the hourly water flow of the tower as

$$\text{Flow} = \text{FlowCTI} * f(\text{APP,WB}) / f(\text{RNG,WB}) * f(\text{air flow})$$

where FlowCTI is the nominal flow rate at CTI conditions, f(APP,WB) is the curve CAP-FAPP&WB, f(RNG,WB) is the curve CAP-FRNG&WB, and f(air flow) is the curve CAP-FAIRFLOW. Note that you do not specify FlowCTI. The program calculates this value based on CAPACITY and the DESIGN-WET-BULB, DESIGN-APPROACH and DESIGN-RANGE temperatures.

CAP-FRNG&WB

Takes the U-name of a bi-quadratic curve that adjusts the flow capacity as a function of the range and wet-bulb. Due to the relationship of range vs. flow capacity the output of this curve is actually the inverse of the adjustment factor.

MAX-RANGE

The maximum value of range for which the CAP-FRNG&WB curve applies. You should not change this value unless you are also redefining the CAP-FRNG&WB curve. In some operation modes, the tower may experience a range much greater than the design range. For example, assume a tower with a single-speed fan has a design range of 10F (5.6K). Currently, the fan is cycling on and off to maintain a setpoint of 85F (29.4C) when the wet-bulb is 40F (4.4C). The attached chiller is operating at half load, so that the average range of the loop and tower is 5F. When the fan is off, the instantaneous temperature drop (range) is less than 5F (2.8K) and the loop temperature rises. When the fan cycles on, the instantaneous temperature drop (range) may be 25-30F (13.9-16.7K), and the loop temperature drops. This effect becomes even more pronounced at lower wet-bulbs (higher approaches). For the program to accurately model this effect, the CAP-FRNG&WB curve must be capable of modeling the instantaneous range of the tower over all expected operating conditions, not just the average range. This is necessary for the algorithm to accurately predict the energy of cycling fans. The MAX-RANGE specifies the maximum instantaneous range for which the CAP-FRNG&WB curve is reasonably accurate. The program will not allow the instantaneous range to exceed this value.

CAP-FAIRFLOW

Takes the U-name of a linear or quadratic curve that adjusts the flow capacity as a function of the air flow through the tower. Cooling towers have an almost linear relationship between air flow and capacity. Fluid coolers, however, do not. At 50% air flow, a fluid cooler may still retain 70% of its capacity. This is because as the air flow drops and the capacity falls off, the temperature differential across the heat-exchanger also drops, which partially compensates for the reduced air flow. For this reason, and because fluid coolers may use up to five times as much fan energy as

an open tower, 2-speed or variable-speed fans may be very cost effective options. The program can simulate all of the common fan control options available.

Open Tower with Heat-exchanger (OPEN-TWR&HX)

The OPEN-TWR&HX component consists of an open tower coupled to its circulation loop with a heat-exchanger. The default tower performance curves for this component are the same as for OPEN-TWR. However, since the heat-exchanger creates a temperature differential between the loop and the tower, the tower's performance will be degraded and its energy consumption will be higher compared to an OPEN-TWR directly coupled to a loop, when operating at the same conditions.

Since the heat-exchanger isolates the tower from the loop, the tower must have its own pump to circulate fluid between the tower and the heat-exchanger. If CW-PUMP is not specified, the program will fetch one from the library. CW-DT for OPEN-TWR&HX is the temperature change through the loop side of the heat-exchanger. DESIGN-RANGE is the temperature change through the tower side of the heat-exchanger. You should override the default (CW-DT) only when the loop-side and tower-side of the heat-exchanger have different flows. CW-HEAD is the pressure drop through the tower (not the heat-exchanger).

CW-FLOW-CTRL is not used for OPEN-TWR&HX units. For a single-cell tower, the flow between the tower and heat-exchanger is constant all hours of operation. For multicell towers, the recirculation flow steps with the number of cells operating.

HX-HEAD

The pressure drop through the heat-exchanger. The pressure drop is assumed to be the same on both sides of the heat-exchanger.

CW-HX

Takes the U-name of a HEAT-EXCHANGER that isolates the tower from the loop. This is a required entry. There are five predefined heat-exchangers in the library called OpenTwr-HX, OpenTwr-HX2, etc., that have TYPE = WATER-TO-WATER and CONFIGURATION = COUNTERFLOW. The UA-PRODUCT of the HEAT-EXCHANGER will default based on the design heat rejection load, the loop and tower flows, and the inlet temperature differential. These 5 heat-exchangers are all identical; multiples are provided in the event you are simulating more than one tower (each tower must reference a different heat-exchanger).

HX-DT

The temperature differential across the inlets of the heat-exchanger. If INLETS-DT of the HEAT-EXCHANGER command is specified, its value will override HX-DT. If the COOL-SETPT-T of the CIRCULATION-LOOP is 85F (29.4C) and the loop has a 10F (5.6K) design temperature rise, then the fluid temperature returning from the loop and entering the heat-exchanger at design conditions will be 95F (35.0C). Since the default inlet differential is 15F (8.3K), the tower temperature entering the heat-exchanger will have to be 80F (26.7C) for the loop temperature setpoint to be satisfied. Note that the 15F (8.3K) inlet differential corresponds to a 5F (2.8K) differential between the tower fluid entering the heat-exchanger and the loop fluid leaving the heat-exchanger.

Fluid Cooler Spray Pump

Fluid coolers come with a factory-mounted spray pump that sprays water over the evaporatively cooled coil. Unlike most other pumps, the spray pump is not defined with a PUMP command. This is because the spray pump always delivers a constant flow and uses constant power whenever operating. The spray pump is defined with the following keywords:

SPRAY-KW/CELL

The power of the spray pump for each cell. The program assumes that each cell has its own spray pump. The default is SPRAY-KW/FLOW times the design flow per cell at CTI conditions.

SPRAY-KW/FLOW

The power per unit flow of the pump, where the flow is the design flow per cell at the CTI conditions.

SPRAY-PUMP-CTRL

Accepts a code-word that specifies how the operation of the spray pump and the fan are coordinated:

STAY-ON Causes the spray pump to operate as the first stage of cooling whenever a heat-rejection load exists. If the load can be met using the spray pump and natural convection, then the fan will stay off. Otherwise, the fan will cycle on as required, and when cycled off, the pump will remain on. For example, a fluid cooler having a 2-speed fan will have three stages of cooling:

Spray pump on, natural convection;

Spray pump on, fan on low speed;

Spray pump on, fan on high speed.

CYCLE-W/FAN Causes the spray pump to operate only when the fan is also operating. This is normally the more energy-efficient mode for a fluid cooler having a 2-speed or variable-speed fan. However, for 2-speed fans, temperature control is somewhat poorer.

Fluid Cooler Dry-Coil Operation

Fluid coolers may operate with a dry coil during winter conditions when the spray water would be subject to freezing conditions. During these periods, the pan may be drained and the spray pump disabled. The fluid cooler will then operate with a dry coil in a manner identical to a dry cooler. Heat transfer across the coil may be substantially degraded during these times, depending on the dry-bulb temperature. For this reason, the outdoor temperature must be relatively cold for the cooler to deliver its design capacity. The following keywords are relevant to dry-coil operation:

WET-COIL-SCH

Takes the U-name of a schedule of TYPE = ON/OFF/TEMP that defines when the coil in the fluid cooler is running wet. The default is a wet coil at all times. If the schedule value is 0.0 the coil runs dry; if it is 1.0, the coil runs wet. Any other value represents an outdoor dry-bulb temperature. If the outdoor temperature is less than this value, then the coil will run dry. For outdoor temperatures above this value, the coil will run wet.

DRY-HX

Takes the U-name of a HEAT-EXCHANGER command. The program uses this heat-exchanger to model the performance of the fluid cooler when running dry. This is a required entry. The library contains five entries named DryCooler-HX, DryCooler-HX2, etc. that have TYPE = AIR-TO-WATER and CONFIGURATION = COUNTERFLOW. Multiples are provided in the event you are modelling more than one fluid cooler (each fluid cooler must reference a different heat-exchanger). The program will calculate the default UA-PRODUCT of the HEAT-EXCHANGER on the basis of the CTI capacity (running wet), the design air and water flow rates, and the DRY-INLET-DT. The hourly performance of the dry coil will depend on the current flow rates and temperatures.

DRY-INLET-DT

The temperature difference across the dry coil necessary to achieve the design heat rejection capacity. For the fluid cooler, the design heat rejection capacity is assumed to be the capacity the tower has when running wet at the CTI conditions (not the CAPACITY you enter at your design wet-bulb, approach and range). The value is the difference between the entering fluid temperature and the entering air temperature.

If the condenser water design setpoint is 85F (29.4C) and the loop has a 10F (5.6K) design temperature rise, then the water entering the cooler at design conditions will be 95F (35C). Since the default differential is 70F (38.9K), the air temperature would have to be 25F (-3.9C) for the cooler to achieve its rated capacity.

For a fluid cooler, the default DRY-INLET-DT assumes that the coil consists of bare tubes. If the fluid cooler has an extended surface coil (fins), then the required inlet temperature difference will be less. A reasonable value for a coil with fins on all its rows would be 48F (26.7K). If only a portion of the rows are finned, then the temperature difference should be somewhere between 48F (26.7K) and 70F (38.9K).

AIR-TO-FLUID-FLOW

The ratio of air flow through the cooler to the fluid flow. For fluid coolers the default is 184 cfm/gpm (82.6 (m³/hr)/(l/min)) at the CTI (wet) conditions. The program uses this value (together with the DRY-AIR-RATIO for the fluid cooler), to calculate the design air flow through the dry coil for use in the DRY-HX calculations. The maximum air flow when running dry will be

$$\text{Air-flow} = \text{Fluid-flowCTI} * (\text{AIR-TO-FLUID-FLOW}) * (\text{DRY-AIR-RATIO})$$

The hourly air flow may be less than this value depending on the load, the air and fluid temperatures, the fluid flow rate, and the type of capacity control.

DRY-AIR-RATIO

The multiplier on the air flow when running with a dry coil. The default is 1.1, meaning that the fan can move 10% more air when the coil is running dry. Maximum fan power also adjusts by this factor. Fluid coolers typically use forward-curved or axial fans. When running dry, the pressure drop across the coil will be less and the fan will ride out on its curve, delivering more air. Power consumption also increases by a similar ratio.

Off-Hours Heat Losses in Fluid Coolers and Coil Freeze Protection

(Not currently implemented)

As described previously, fluid coolers may need to operate in the winter, most commonly to reject heat from a water-loop heat-pump system. The pan can be protected from freezing by draining it and running the cooler with a dry coil; however, this does not prevent the coil itself from freezing when the loop is shut down. Freeze protection for the coils commonly consists of one of the following measures:

Locating the fluid cooler in an enclosed space;

Using a glycol mixture in the loop; or

Restarting the loop and circulating heated fluid through the cooler whenever the ambient conditions endanger the coil.

While option (3) is the least energy efficient (particularly in cold climates), it is also the least expensive option and is commonly done. The following keywords define the heat loss characteristics of the coil during this mode of operation:

COIL-LOSS

The thermal loss of the fluid cooler at the design fluid temperature, ambient temperature and wind speed. If not specified, the losses will default according to the COIL-LOSS-RATIO. The program uses this value, together with the design COIL-FLUID-T, COIL-AMBIENT-T and COIL-WINDSPEED to derive an effective loss coefficient for the fluid cooler (see 1993 ASHRAE Handbook of Fundamentals, p. 22.17, eqn. 4). This coefficient is then used hourly to determine the actual heat loss.

COIL-LOSS-RATIO

The ratio of the design fluid cooler losses to the design heat rejection capacity at the CTI conditions. This keyword is ignored if you specify COIL-LOSS. The default assumes that the fluid cooler has a hood and positive closure dampers to isolate the coil from the ambient air when shut down. If the cooler does not have these dampers, then the loss will be approximately 2.5 times greater and the loss ratio should be increased to about 0.17. Fluid coolers can also be purchased with insulation in addition to the positive closure dampers. The insulation reduces the loss by approximately 1/3, so that a reasonable input for this keyword would be 0.05.

COIL-FLUID-T

The temperature of the fluid in the coil at which the design COIL-LOSS occurs. This value is used in the calculations for the design coil loss coefficient.

COIL-AMBIENT-T

The ambient air temperature at which the design COIL-LOSS occurs. This value is used to calculate the design coil loss coefficient.

COIL-WINDSPEED

The wind speed at which the design COIL-LOSS occurs. This value is used to calculate the design coil loss coefficient.

During normal WLHP operation, the heat loss from the fluid cooler may or may not be zero depending on whether the cooler has a valve that isolates the cooler from the loop when heat rejection is not needed.

If the loop is shut down and you want to restart the loop to protect the coil from freezing, you must specify RESTART-AIR-T for the CW loop. The loop will go into the freeze protection mode whenever the outdoor air temperature drops below this value (45F [7.2C] is reasonable); values below this may be dangerous because of the effect of night sky radiation). If the loop is already running, but not in the heat rejection mode, then the isolation valve will open and the loop will continue to operate at the current temperature setpoint. If the loop is not operating, then it will start (pumps running and boiler enabled) and will operate at RESTART-SETPT-T of the CW loop, or the normal loop setpoint, whichever is greater. The loop will continue to operate until the outdoor temperature rises above the RESTART-AIR-T.

Fluid cooler manufacturers commonly recommend that the temperature for an unprotected coil never be allowed to drop below 50F (10C). To reduce the losses associated with the freeze protection mode, glycol can be added to the loop fluid to reduce its freezing point. For example, if enough glycol is added to provide freeze protection down to 10F (-12.2C), then the manufacturer might reduce the minimum recommended coil temperature from 50F (10C) to 25F (-3.9C).

Note that the addition of glycol will degrade the performance of the WLHP units and the heat-rejection capacity of the fluid cooler. The program does not currently model these effects directly. For now, you can approximate these effects by modifying the EIRs of the WLHP units, and increasing the fan horsepower of the fluid cooler. For example, a 40% glycol solution will reduce a fluid cooler's capacity by approximately 20%. To compensate, increase the ELEC-INPUT-RATIO for HEAT-REJECTION by 25%. Pump horsepower must also be increased to overcome the higher fluid viscosity.

Pan Freeze Protection

If a tower or fluid cooler is located outdoors and must operate near or below freezing temperatures, then some means must be provided to prevent the water in the pan from freezing when the unit is not operating. One method is to drain the water and store it in a remote sump located in an area not subject to freezing. The pan in a fluid cooler can be drained, the spray pump disabled, and the unit operated with a dry coil for the duration of the winter (see "Fluid Cooler Dry-Coil Operation," above). Another method is to provide a thermostatically-controlled pan heater. The following keywords are related to pan freeze protection:

PAN-HEATER-TYPE

Accepts a code-word that specifies the type of pan heater:

NONE	No pan losses are to be simulated.
ELECTRIC	An electric immersion heater.
HOT-WATER	A CIRCULATION-LOOP provides the heat.

PAN-LOSS

The thermal loss of the pan at the design pan fluid temperature, ambient temperature and wind speed. If not specified, the losses will default according to the PAN-LOSS-RATIO. The program uses this value, together with the design PAN-FLUID-T, PAN-AMBIENT-T and PAN-WINDSPEED, to derive an effective loss coefficient for the fluid cooler (see 1993 ASHRAE Handbook of Fundamentals, p. 22.17, eqn. 4). This coefficient is then used hourly to determine the actual heat loss.

PAN-LOSS-RATIO

The ratio of the design pan losses to the design heat rejection capacity at the CTI conditions.

PAN-FLUID-T

The temperature of the fluid in the pan at which the design PAN-LOSS occurs. This value is used in the calculation for the effective pan loss coefficient. It is also used as the setpoint for the pan heater.

PAN-AMBIENT-T

The ambient air temperature at which the design PAN-LOSS occurs.

PAN-WINDSPEED

The wind speed at which the design PAN-LOSS occurs.

PAN-HEATER-LOOP

Takes the U-name of a CIRCULATION-LOOP when PAN-HEATER-TYPE = HOT-WATER. The loop must be of TYPE = HW or PIPE2.

PAN-HEATER-HEAD

The head due to friction loss in the pan heater coil when PAN-HEATER-TYPE = HOT-WATER.

PAN-VALVE-TYPE

Takes a code-word that specifies the type of valve that modulates the flow through the pan heater coil when PAN-HEATER-TYPE = HOT-WATER. Allowed values are:

TWO-WAY	A 2-way valve. The program assumes the flow is linear with load.
THREE-WAY	A 3-way valve that maintains a constant flow by bypassing the flow not needed by the coil to the return side of the circulation loop.

PAN-HEATER-DT

The design temperature drop through the pan heater coil when PAN-HEATER-TYPE = HOT-WATER. The default is the LOOP-DESIGN-DT of the PAN-HEATER-LOOP.

Dry Cooler Performance

A dry cooler is simply an air-to-water heat-exchanger with one or more integral fans. The device is located outdoors and rejects the heat of a condenser water loop. Since the unit is not evaporatively cooled the loop temperature will always be above the ambient dry-bulb temperature. In hot climates, this can have a significant impact on cooling unit efficiency.

DRY-HX

Takes the U-name of the HEAT-EXCHANGER the program will use to model the performance of the fluid cooler when running dry. This is a required entry when WET-COIL-SCH is specified. The library contains five entries named DryCooler-HX, DryCooler-HX2, etc., that have TYPE = AIR-TO-WATER and CONFIGURATION = COUNTERFLOW (multiples are provided in the event you are simulating more than one dry cooler. Each dry cooler must have a different heat-exchanger). The program will calculate the default value of the UA-PRODUCT of the HEAT-EXCHANGER from the CTI capacity (running wet), the design air and water flow rates, and the value of DRY-INLET-T. The performance of the dry coil will depend on the hourly flow rates and temperatures.

DRY-INLET-DT

The temperature difference across the dry coil needed to achieve the design heat rejection capacity. If the condenser water design setpoint is 85F (29.4C), and the loop has a 10F (5.6K) design temperature rise, then the water entering the cooler at design conditions will be 95F (35.0C). Since the default inlet differential is 25F (13.9K), the air temperature would have to be 70F (21.1C) for the cooler to achieve its rated capacity when the loop supply is at 85F (29.4C). If the ambient temperature rises to 110F (43.3C), then the loop supply temperature will be 125F (51.7C) when rejecting the design load. You must verify that the cooling equipment attached to this loop has temperature capacity and performance curves consistent with the maximum expected condenser loop supply temperature. Serious errors may result if the curves were not developed anticipating this type of temperature.

AIR-TO-FLUID-FLOW

The ratio of design air flow through the dry cooler to the fluid flow. The program uses this value to calculate the design air flow through the dry coil for use in the DRY-HX calculations. The maximum air flow will be

$$\text{Air-flow} = \text{Fluid-flowCTI} * (\text{AIR-TO-FLUID-FLOW})$$

The hourly air flow may be less than this value depending on the load, the air and fluid temperatures, the fluid flow rate, and the type of capacity control.

Temperature Control in Cooling Towers

The supply temperature that a tower will attempt to achieve is set by the attached CIRCULATION-LOOP through the COOL-SETPT-CTRL, COOL-SETPT-T, COOL-RESET-SCH, COOL-SETPT-SCH, and LOOP-SETPT-RNG keywords (see CIRCULATION-LOOP command). For open towers and fluid coolers only there is one additional temperature control mode available that tries to achieve an optimal compromise between tower fan energy and cooling compressor energy. You activate this sequence by with COOL-SETPT-CTRL = LOAD-RESET in the attached CIRCULATION-LOOP. The sequence is as follows:

The chiller load is determined on an hourly basis. In the field, this would be accomplished either by a monitoring a signal directly from the chiller control panel, or, perhaps more commonly, by measuring the temperature rise across the chiller condenser, and comparing it to the design temperature rise. For

example, if the design condenser temperature rise is 10F (5.6K), and the actual rise is 6F (3.3K), then the chiller load is assumed to be 60%. (This assumes that the condenser is constant flow.)

The tower air flow (and fan speed) required to reject a given chiller load is essentially linear with load (open towers) or drops off faster than the load (fluid coolers). Rather than controlling a variable-speed tower fan on the basis of leaving tower temperature as is conventionally done, this algorithm will vary the tower fan speed directly on the basis of chiller load. For the example given above, the tower fan will run at 60% speed when the chiller load is 60%. The leaving tower temperature then floats with both wet-bulb temperature and chiller load. This concept gives priority to minimizing tower energy consumption, but still achieves chiller energy savings as the leaving tower temperature floats.

To further increase chiller efficiency, it can be recognized that the tower fan power varies approximately as the cube of the air flow (and load), and that the majority of the energy savings are achieved when the fan is close to full speed. Once the fan speed has been reduced to 70% or so, additional tower fan energy savings will be negligible compared to the potential chiller savings that might be achieved by reducing the approach to the wet-bulb.

Keywords are provided to allow you to experiment with this concept. For example, at 50% load the default fan speed will be 50%. You might want to investigate what happens if the tower fan is not allowed to drop below 65% speed at 40% load.

Maximum and minimum condenser temperature limits are included. For example, you might not want the leaving tower temperature to ever exceed 85F (29.4C) or to drop below 65F (18.3C). The fan speed algorithm described in (2) and (3) will be overridden to ensure that these limits are not exceeded.

Two-speed tower fans use a variation of this algorithm. As before, the tower will cycle between low and high speed to maintain the tower setpoint. However when the leaving temperature drops below the setpoint, the fan will not cycle between off and low speeds. Instead, the fan will remain on low speed unless the leaving temperature drops all the way down to MIN-TWR-WTR-T, at which point it will cycle between off and low to prevent the tower temperature from dropping any further.

This control sequence is not applicable to single-speed fans. It applies to both CW loops as well as WLHP loops. Maximum energy savings might be achieved for WLHP loops, as these systems typically have a lower cooling COP than chillers, and the heat rejection commonly uses a fluid cooler which has a higher fan horsepower than an equivalent open tower.

When using the LOAD-RESET control sequence, you can try experimenting with the values of the MIN-RESET-PLR, MIN-VFD-SPEED, MAX-RESET-SPEED to optimize the energy efficiency of the system.

The LOAD-RESET tower keywords are illustrated in Figure 36 and are as follows:

MIN-RESET-PLR

The minimum tower part load ratio below which a variable-speed tower fan is no longer modulated. Below this fraction, the fan speed is held constant at MIN-VFD-SPEED. This keyword allows you to investigate control sequence (3), above. This keyword is ignored for all control schemes other than LOAD-RESET. See Figure 36.

MIN-VFD-SPEED

The minimum speed ratio below which the tower fan variable frequency drive should never operate. For control sequences other than LOAD-RESET, this keyword specifies the "critical speed" below which the tower fan should not operate. For the LOAD-RESET sequence, this keyword specifies the speed at which the fan will operate when the tower load is at MIN-RESET-PLR. The default is 0.4 except for dry coolers, where it is 0.2. See Figure 36.

For example, assume that a tower fan is to operate at 100% speed when the tower heat rejection load is 100% of design, and is to ramp down to 60% speed when the tower load is 40% of design. This is specified as MIN-VFD-SPEED = 0.6 and MIN-RESET-PLR = 0.4. The defaults of 0.4 for MIN-VFD-SPEED and 0.3 for MIN-RESET-PLR mean that a variable-speed tower fan will operate at 40% speed at any load below 30% of design load. If the supply temperature drops below the CIRCULATION-LOOP's MIN-RESET-T, then the fan will cycle to maintain the MIN-RESET-T.

MAX-RESET-SPEED

The maximum speed ratio of a variable-speed tower fan during LOAD-RESET. The fan speed will not exceed this value, regardless of load, unless the tower temperature exceeds the CIRCULATION-LOOP's COOL-SETPT-T. If the tower temperature floats above the setpoint, then control reverts to FIXED for that hour, the fans are controlled to maintain the setpoint, and this keyword is ignored. The default is 0.8, which means that the fans will operate at 80% speed when the load is 100% of design, unless the COOL-SETPT-T is exceeded. See Figure 36.

CIRCULATION-LOOP:COOL-SETPT-T

The maximum allowable temperature during LOAD-RESET. If the leaving tower temperature floats above this temperature, the fans will modulate as required to maintain this maximum temperature.

CIRCULATION-LOOP:MIN-RESET-T

The minimum allowable temperature during LOAD-RESET. If the leaving tower temperature floats below this temperature, the fans will modulate as required to maintain this minimum temperature.

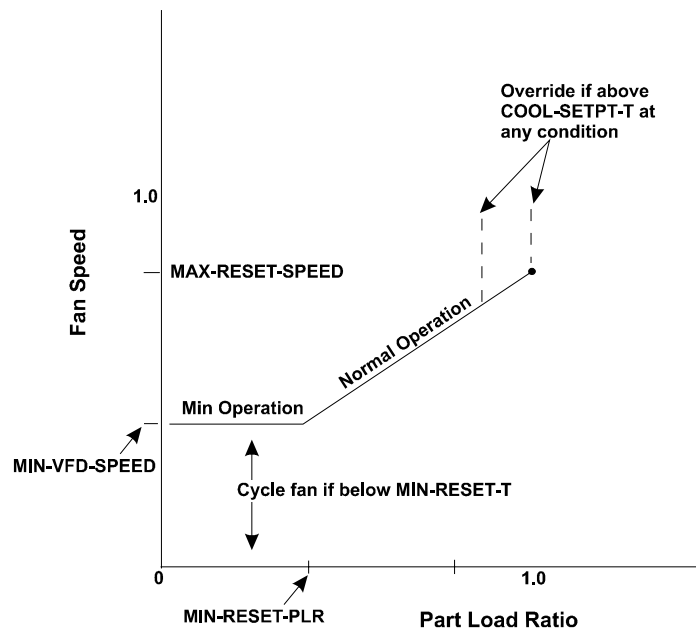

Figure 36 Heat-rejection load reset

LOAD-MANAGEMENT

The LOAD-MANAGEMENT command is used to specify the hourly mix of EQUIP-CTRL sequences that will be applied to the various CIRCULATION-LOOPS and ELEC-METERS. The LOAD-MANAGEMENT sequences allow you to switch the EQUIP-CTRL sequences according to a variety of parameters including time of day or year, outdoor air temperature, and electrical peak shaving (future implementation). In addition, this command can override the on/off control mechanism of CIRCULATION-LOOPS, and either force them to operate or to shut down. For LOAD-MANAGEMENT and EQUIP-CTRL examples, see "Load Management and Equipment Control" in the *DOE-2.2 Topics*.

U-name is required.

TYPE

Accepts a code-word specifying the type of control this sequence will use.

SCHEDULED	The program will select different EQUIP-CTRL sequences according to the time of day or year. You will most commonly use this mode when you want to either restrict the use of thermal-storage to specific times of the day, or switch from electric chillers to absorption chillers or engine chillers on a scheduled basis.
OA-TEMP	The program will select different EQUIP-CTRL sequences according to the outdoor air temperature. A common example of this application would be a central plant having chillers that sequence according to the outdoor temperature, rather than load.
ZONE-TEMP	The program will select different EQUIP-CTRL sequences according to a zone temperature (previous hour's temperature). A common example of this application would be a reheat loop that is enabled or disabled on the basis of a zone temperature.
LOOP-LOAD	The program will select different EQUIP-CTRL sequences according to a circulation loop load. This mode allows you to select the equipment serving one loop on the basis of another loop's load. For example, you might want to preferentially run a double bundle chiller or engine chiller only when there is a concurrent heating load suitable for the chiller's recoverable heat. In a similar fashion, an ELEC-GENERATOR may start only when there is a heating load.
PEAK-SHAVING	(future, not implemented in this release) When peak shaving, the program will first use the EQUIP-CTRL sequences in the first list and simulate the equipment. If this equipment mix results in the peak demand limit being exceeded the program will select the EQUIP-CTRL sequences in the second list, and will re-simulate the central plant equipment for the same hour. If the demand still exceeds the limit the program will repeat this sequence until it has found the mix of EQUIP-CTRL sequences that do not exceed the peak, or until no more configurations remain. The PEAK-SHAVING mode assumes that the EQUIP-CTRL sequences in the second and following mixes enable thermal storage equipment, switch to gas-fired chillers, enable electrical generators, and/or deliberately do not meet all loads.

The following two keywords determine whether the LOAD-MANAGEMENT sequence is active this hour.

QUAL-SCH

Accepts the U-name of a schedule that defines when the LOAD-MANAGEMENT sequence is active. The schedule must be of TYPE = FLAG. If QUAL-SCH is not specified the LOAD-MANAGEMENT sequence will be active all hours. This schedule applies to all TYPEs of the LOAD-MANAGEMENT command and provides an additional level of control; do not confuse it with EQUIP-CTRL_SCH, below, which is used to switch EQUIP-CTRL sequences when TYPE = SCHEDULED.

QUAL-SCH-FLAG

Accepts a numeric flag value corresponding to one of the flag values listed in QUAL-SCH. The -LOAD-MANAGEMENT sequence will be active whenever the schedule is using the same flag as this value.

EQUIP-CTRL-SCH

When LOAD-MANAGEMENT:TYPE = SCHEDULED, accepts the U-name of the schedule containing the flags used to switch EQUIP-CTRL sequences and/or enable or disable CIRCULATION-LOOPS according to the time of day or year. This is a mandatory entry. The schedule must be of TYPE = FLAG.

CTRL-ZONE

When TYPE = ZONE-TEMP, this is a mandatory entry that accepts the U-name of the ZONE whose temperature will be used to switch EQUIP-CTRL sequences and/or enable or disable CIRCULATION-LOOPS. This is a mandatory entry.

CTRL-LOOP

When TYPE = LOOP-LOAD, this is a mandatory entry that accepts the U-name of the CIRCULATION-LOOP whose load will be used to switch EQUIP-CTRL sequences that apply to another loop.

CTRL-FLAG-1**CTRL-FLAG-2****CTRL-FLAG-3****CTRL-FLAG-4****CTRL-FLAG-5**

When TYPE = SCHEDULED, accepts a numeric flag value corresponding to one of the flag values in the EQUIP-CTRL-SCH. When these values match, the program broadcasts the EQUIP-CTRL sequences listed in EQUIP-CTRLS-n to their respective circulation loops or electric meters.

TEMPS-THRU-1**TEMPS-THRU-2****TEMPS-THRU-3****TEMPS-THRU-4****TEMPS-THRU-5**

When TYPE = OA-TEMP or ZONE-TEMP, accept a numeric value specifying the maximum temperature for this range. When the temperature is less than or equal to this value, the program broadcasts the EQUIP-CTRL sequences listed in EQUIP-CTRLS-n to their respective circulation loops or electric meters. You must enter values for the TEMPS-THRU-1 through TEMPS-THRU-5 ranges in ascending numerical order. The program will stop searching as soon as it finds a range having a temperature greater than or equal to the current temperature.

LOADS-THRU-1**LOADS-THRU-2****LOADS-THRU-3****LOADS-THRU-4****LOADS-THRU-5**

When TYPE = LOOP-LOAD, accept a numeric value specifying the maximum loop load for this range. When the load is less than or equal to this value, the program broadcasts the EQUIP-CTRL sequences listed in EQUIP-

CTRLS-n to their respective circulation loops or electric meters. You must enter values for the LOADS-THRU-1 through LOADS-THRU-5 ranges in ascending numerical order. The program will stop searching as soon as it finds a range having a load greater than or equal to the current load.

EQUIP-CTRLS-1**EQUIP-CTRLS-2****EQUIP-CTRLS-3****EQUIP-CTRLS-4****EQUIP-CTRLS-5**

For TYPE = SCHEDULED, OA-TEMP, or ZONE-TEMP, accepts a list in parenthesis of the U-names of the EQUIP-CTRL sequences to be used when the CTRL-FLAG-n or TEMPS-THRU-n condition is true. There is no default. Up to 22 EQUIP-CTRL sequences may be listed. It is not necessary to list any EQUIP-CTRL sequences here. In this case, the equipment mix for each loop or electric meter will either default or be selected according to the locally defined EQUIP-CTRL sequences.

LOOPS-ON-1**LOOPS-ON-2****LOOPS-ON-3****LOOPS-ON-4****LOOPS-ON-5**

For TYPE = OA-TEMP or ZONE-TEMP, accepts a list of CIRCULATION-LOOPS that are to be forced to operate this hour. This control overrides CIRCULATION-LOOP:LOOP-OPERATION = STANDBY, DEMAND or SCHEDULED, but not SNAP.

LOOPS-OFF-1**LOOPS-OFF-2****LOOPS-OFF-3****LOOPS-OFF-4****LOOPS-OFF-5**

For TYPE = OA-TEMP or ZONE-TEMP, accepts a list of CIRCULATION-LOOPS that are to be forced off this hour. This control overrides the CIRCULATION-LOOP:LOOP-OPERATION = STANDBY, DEMAND or SCHEDULED, but not SNAP.

CTRL-PRIORITY-1**CTRL-PRIORITY-2****CTRL-PRIORITY-3****CTRL-PRIORITY-4****CTRL-PRIORITY-5**

Accepts a numeric value in the range of 1-100, where 1 is the lowest priority, and 100 is the highest. This value is the command priority that applies to all EQUIP-CTRL sequences listed under EQUIP-CTRL-n. You can define multiple LOAD-MANAGEMENT sequences and these sequences can broadcast conflicting EQUIP-CTRL sequences to the various loops. The program resolves these conflicts via CTRL-PRIORITY-n. For a given loop or electric meter, the EQUIP-CTRL sequence broadcast with the highest priority will override all others. Note that EQUIP-CTRL sequences attached locally to a loop via the CIRCULATION-LOOP:HEAT-EQUIP-CTRL or COOL-EQUIP-CTRL have a command priority of 0. This allows all LOAD-MANAGEMENT broadcasts to override the locally defined control.

This keyword also applies to the LOOPS-ON-n and LOOPS-OFF-n instructions.

You can enter multiple sets of data using the CTRL-FLAG-n, TEMPS-THRU-n, EQUIP-CTRL-n, and CTRLS-PRIORITY-n sets of keywords. Normally, you should define set #1 first, then set #2, etc.

Not all control ranges need to have values. For example, if you are defining a control sequence of TYPE = OA-TEMP, and want to override the local loop control only when the outdoor temperature exceeds 90F, your input could be:

```
LM-HIGH-TEMP = LOAD-MANAGEMENT
  TYPE                = OA-TEMP
  TEMPS-THRU-1       = 89.
  TEMPS-THRU-2       = 120.
  EQUIP-CTRLS-2      = (EC-ABSOR, EC-GENERATE)
  CTRL-PRIORITY-2    = 10    ..
```

In this example, EQUIP-CTRL-2 will be used whenever the outdoor temperature is above 89F, and EQUIP-CTRL-1 will be used when the temperature is lower than 90F. However, since there are no EQUIP-CTRL sequences listed in EQUIP-CTRL-1, no sequences will be broadcast.

MASTER-METERS

Defines the electric and fuel meters that will be used by default. A single default electric and/or fuel meter can be specified or different default meters can be specified for each of the energy end-use categories supported by the program. The MASTER-METERS command must proceed all other HVAC commands. This is because default values for HVAC equipment are determined from their MASTER-METERS values.

If none is specified upon BDL's reading of the first HVAC equipment command, one is created with MSTR-ELEC-METER defaulting to a library ELEC-METER (EM1) and MSTR-FUEL-METER defaulting to a library FUEL-METER (FM1 which is natural gas).

Example Input:

```
MASTER-METERS
MSTR-ELEC-METER   = "EM20 "
MSTR-FUEL-METER   = "FM20 " ..
```

MSTR-ELEC-METER

Accepts the U-name of the electric meter to be used as the master electric meter. All electric meter attachments in all components will default to this meter unless specified otherwise within the component command, or unless the appropriate master end-use meter is specified (see following).

MSTR-FUEL-METER

Accepts the U-name of the fuel meter to be used as the master fuel meter. All fuel meter attachments in all components will default to this meter, unless specified otherwise within the component command, or unless the appropriate master end-use meter is specified (see following).

LIGHT-ELEC- METER

Accepts the U-name of the electric meter to be used as the master electric meter for all general lighting. The default is the MSTR-ELEC-METER.

TASK-ELEC-METER

Accepts the U-name of the electric meter to be used as the master electric meter for all task lighting. The default is the MSTR-ELEC-METER.

EQUIP-ELEC-METER

Accepts the U-name of the electric meter to be used as the master electric meter for all miscellaneous equipment (computers, copiers, etc.). The default is the MSTR-ELEC-METER.

SOURCE-ELEC-METER

Accepts the U-name of the electric meter to be used as the master electric meter for all source usage. The default is the MSTR-ELEC-METER.

HEAT-ELEC-METER

Accepts the U-name of the electric meter to be used as the master electric meter for all space heating. The default is the MSTR-ELEC-METER.

COOL-ELEC-METER

Accepts the U-name of the electric meter to be used as the master electric meter for all space cooling. The default is the MSTR-ELEC-METER.

HTREJ-ELEC-METER

Accepts the U-name of the electric meter to be used as the master electric meter for all heat-rejection equipment (cooling towers, etc.). The default is the MSTR-ELEC-METER.

AUX-ELEC-METER

Accepts the U-name of the electric meter to be used as the master electric meter for all HVAC auxiliary equipment (pumps, etc.). The default is the MSTR-ELEC-METER.

VENT-ELEC-METER

Accepts the U-name of the electric meter to be used as the master electric meter for all ventilation fans. The default is the MSTR-ELEC-METER.

REFG-ELEC-METER

Accepts the U-name of the electric meter to be used as the master electric meter for all refrigeration equipment. The default is the MSTR-ELEC-METER.

SUPP-ELEC-METER

Accepts the U-name of the electric meter to be used as the master electric meter for all supplemental heating in electric heat-pumps. The default is the MSTR-ELEC-METER.

DHW-ELEC-METER

Accepts the U-name of the electric meter to be used as the master electric meter for all water heating equipment. The default is the MSTR-ELEC-METER.

SOURCE-FUEL-METER

Accepts the U-name of the electric meter to be used as the master fuel meter for all source usage. The default is the MSTR-FUEL-METER.

HEAT-FUEL-METER

Accepts the U-name of the electric meter to be used as the master fuel meter for all space heating. The default is the MSTR-FUEL-METER.

COOL-FUEL-METER

Accepts the U-name of the electric meter to be used as the master fuel meter for all space cooling. The default is the MSTR-FUEL-METER.

SUPP-FUEL-METER

Accepts the U-name of the fuel meter to be used as the master fuel meter for all supplemental heating in electric heat-pumps. The default is the MSTR-FUEL-METER.

DHW-FUEL-METER

Accepts the U-name of the fuel meter to be used as the master fuel meter for all water heating equipment. The default is the MSTR-FUEL-METER.

Time-Dependent Valuation

Many building energy codes distinguish between energy consumed on site versus the actual source energy required to produce and deliver the site energy. For example, it is commonly assumed that for every unit of electricity consumed on site, three units are consumed in the generating plant and in transmission losses. (Actually, the original 3:1 ratio was based on the assumption the electricity *costs* 3x as much to generate and deliver than the source fuel; so it never actually represented source energy.) The conversion factors for site vs. source energy are specified in the

SOURCE-SITE-EFF keywords in the various types of meters, and the BEPS and BEPU reports account for differences in site vs. source energy consumption using these factors.

The State of California takes this logic one step further, and weights the "source" energy factors hourly to take into account differences in the delivered cost of energy for different seasons, outdoor temperatures, and time of use. For electricity consumption these costs include the costs of providing sufficient generation, transmission and distribution capacity which are allocated to those hours of highest electricity consumption. These costs also include the variable costs of producing power and fixed cost allocated evenly by consumption for administration, profit etc. The costing for gas and propane is less variable than electricity but includes the seasonal fluctuations in cost; gas is cheaper in the summer than in the winter.

The hourly ratios used to weight the site energy are termed "time-dependent valuation factors", or "TDV factors", and the equivalent energy produced is termed "TDV energy". TDV energy is in units of nominal kBtu of natural gas based upon long term forecasts of the relative cost of electricity, natural gas and propane. Fuels other than natural gas or propane are recognized as being equivalent to propane.

The TDV factors are specific to each of the 16 official California Climate Zones used to show compliance with the State's energy code. Whenever one of these climate zones is used in a simulation (CZ01 thru CZ16), the program automatically loads the appropriate hourly values of the TDV factors, and weights the hourly site energy consumption by these factors to determine the hourly TDV energy. This linkage is completely automatic; since the TDV data is dependent on outdoor temperature (the hottest days have the highest generating and transmission costs), it would not make sense to use this data with a weather file other than the one for which it was created.

The TDV energy is tabulated in reports TDV1 and TDV2. TDV1 is similar to the BEPS report, and is generated automatically whenever the BEPS report is specified, and one of the 16 California climate zones is used. Similarly, TDV2 is similar to the PS-F meter report, and is generated automatically for each meter whenever the PS-F reports are enabled together with one of the California climate zones. Refer to the *Libraries & Reports* for more information on these reports.

California also requires that outdoor lighting not be included in a compliance analysis simulation. For this reason, if outdoor lighting is specified (ELEC-METER:EXTERIOR-POWER, with EXTERIOR-EU = EXT-USAGE), the EXT-USAGE end-use category is by default not included in TDV1 or TDV2. Exterior power is included in all other reports, as well as the costs computed in the UTILITY-RATE(s).

If a user wishes to override the default exclusion of the EXT-USAGE end-use from these two reports, the following keyword is provided within the MASTER-METERS command:

EXCLUDE-FROM-TDV

accepts a list of code words specifying which end-uses are to be excluded from the TDV1 and TDV2 time-dependent valuation reports. Acceptable entries are NONE (all end-uses are included), LIGHTS, TASK-LIGHTS, MISC-EQUIP, SPACE-HEATING, SPACE-COOLING, HEAT-REJECT, PUMPS&AUX, VENT-FANS, REFRIG-DISPLAY, HT-PUMP-SUPPLEM, DOMEST-HOT-WTR, and EXT-USAGE. The default is EXT-USAGE.

MATERIALS-COST

Defines the costs associated with a primary HVAC component. These costs include first costs, operating costs (other than energy), maintenance costs, maintenance intervals, etc. U-name is required.

FIRST-COST

The first cost for the item, not including installation costs. This cost must be entered in dollars referenced to the same point in time as all other cost input. For example, if energy costs refer to January 1998, this cost must be converted to January 1998 dollars before it is entered regardless of the actual expenditure date. If the money is spent before start up and operation, the present value is increased by the lost opportunity value over the time interval between spending and start up. The HVAC program is not capable of calculating this increased value. You are required to calculate increased value before entering the cost. This is the present value of the cost; it may be approximated by the following equation:

$$c_{pv} = c_r (1 + D/100)^N$$

where

c_{pv}	present value of cost
D	real discount rate in per cent per time interval, and
N	number of time intervals from expenditure to start up.

INSTALLATION

The multiplier on equipment FIRST-COST to estimate first cost per unit installed. For example, if installation cost is 20% of first cost, then INSTALLATION = 1.2.

CONSUMABLES

The cost per hour of those items consumed during operation (excluding primary fuel). For example, diesel fuel for an engine is not in the consumables category but lubricating oil is.

MAINTENANCE

The hours per year of required on-site maintenance for the equipment item. The program will use this value along with the hourly cost of labor (specified with the LABOR keyword in the BASELINE command) to calculate yearly maintenance costs for the equipment item. Maintenance refers to the standard level of upkeep by on-site personnel, excluding overhauls.

EQUIPMENT-LIFE

The number of operating hours from the time the equipment is new until it must be replaced. Note that this number is the same for new and existing building simulation.

MINOR-OVHL-COST

The cost for a minor overhaul of an equipment item.

MINOR-OVHL-INT

The expected number of operating hours between minor overhauls for the equipment item.

MAJOR-OVHL-INT

The expected number of operating hours between major overhauls for the equipment item.

MAJOR-OVHL-COST

The cost for a major overhaul of the equipment item.

HOURS-USED

Required for economic analysis of existing buildings and equipment. The number of hours entered should equal the operating hours already on the equipment. It is important that the number of hours used is not equal to or greater than the value entered or defaulted for EQUIPMENT-LIFE since this will result in calculation error. If the actual hours used is less than EQUIPMENT-LIFE, estimate the remaining useful life. Subtract the remaining useful life from EQUIPMENT-LIFE and enter the difference as the value for HOURS-USED. Note that a non-zero value of HOURS-USED implies that the equipment is not new, so no first-cost data will appear in output reports except for replacements.

PLANT-REPORT

Specifies which of the standard verification and summary reports to print. Examples of these reports along with a description of each can be found in *DOE-2.2 Libraries & Reports*. Verification reports echo your input in a modified form or show results of system sizing. Summary reports show calculation results, usually monthly and annually. The time period covered in the summary reports is given by BEGIN-MONTH, BEGIN-DAY, END-MONTH and END-DAY in the RUN-PERIOD command. The example below shows how to print verification report SV-A, "System Design Parameters," and summary reports SS-A, "System Monthly Loads Summary," and SS-O, "Temperature Scatter Plot."

Example Input:

```
PLANT-REPORT
  VERIFICATION      = (PV-A)
  SUMMARY           = (PS-A, PS-O) . .
```

VERIFICATION

Takes a list of code-words that identify the PLANT verification reports to be printed. See *DOE-2.2 Libraries & Reports*.

PV-A PLANT DESIGN PARAMETERS
This report summarizes the design information for each component simulated in the central plant(s).

SUMMARY

Takes a list of code-words that identify the PLANT summary reports to be printed. See *DOE-2.2 Libraries & Reports*.

PS-A PLANT ENERGY UTILIZATION
This report shows monthly site energy use and demand for the central plant disaggregated into various categories. It also gives the total source energy. Thermal quantities are given in MBtu (English) or MWh (metric). Electrical quantities are given in MWh.

PS-B UTILITY AND FUEL USE SUMMARY
This report shows the monthly total consumption and peak hourly consumption (and associated time of occurrence) for all of the electric meters, fuel meters, etc., including submeters.

PS-C EQUIPMENT LOADS AND ENERGY USE
For each central plant component, this report lists the unit's yearly heating and/or cooling load, the electrical and fuel consumption, and performance information in a bin format. This report is for the central plant equipment components only; report PS-D summarizes the performance of circulation loops.

PS-D CIRCULATION LOOP LOADS
This report summarizes the performance of all the circulation-loops. Only loop performance is reported here; report PS-C summarizes the performance of the primary equipment attached to the loops.

PS-E ENERGY END-USE SUMMARY FOR
 ALL ELECTRIC METERS
 ALL FUEL METERS
 ALL STEAM METERS

ALL CHW METERS

There are up to four PS-E reports, one for electricity usage, one for fuel usage, one for steam utility usage (if one or more steam meters is defined), and one for chilled-water utility usage (if one or more chilled-water meters is defined). For each month, these reports list, for different end uses, the total usage, the peak usage, and the day/hour during which the peak occurred. Also listed, for each end-use, is that end-use's consumption at the time of the total peak consumption, and the percentage of the total peak that end-use represents.

- PS-F ENERGY END-USE SUMMARY FOR <meter name>
This report is similar to PS-E, but rather than aggregate all electric meters fuel meters, steam meters, and/or chilled-water meters, this report is printed for each separate meter. For each month, these reports list, for different end uses, the total usage, the peak usage, and the day/hour during which the peak occurred. Also listed, for each end-use, is that end-use's consumption at the time of the meter's peak consumption, and the percentage of the meter's peak that end-use represents.
- PS-H LOAD AND ENERGY USAGE FOR <loop name>
For each circulation loop, this report summarizes relevant design information as well as monthly and yearly performance. This report is an expansion of the information provided in PV-A and PS-D; most of the information will be identical with the exception of the monthly performance. For this report to print, PS-H must be specified in PLANT-REPORTS, and the circulation loop's EQUIPMENT-REPORTS = YES.
- PS-H LOAD AND ENERGY USAGE FOR <pump name>
For each pump, this report summarizes relevant design information as well as monthly and yearly performance. This report is an expansion of the information provided in PV-A and PS-C; most of the information will be identical with the exception of the monthly performance. For this report to print, PS-H must be specified in PLANT-REPORTS, and the pump's EQUIPMENT-REPORTS = YES.
- PS-H LOAD AND ENERGY USAGE FOR <equipment name>
This report summarizes the performance of primary equipment components such as boilers, chillers, cooling towers, etc. The reports vary by component, but are very similar in format. This presentation uses a boiler as the example. For the component, this report summarizes relevant design information as well as monthly and yearly performance. This report is an expansion of the information provided in PV-A and PS-C; most of the information will be identical with the exception of the monthly performance. For this report to print, PS-H must be specified in PLANT-REPORTS, and the component's EQUIPMENT-REPORTS = YES.
- BEPS BUILDING ENERGY PERFORMANCE
This report makes it possible to quickly review annual building energy use according to energy type (ELECTRICITY, NATURAL-GAS, etc.) and category of use (LIGHTS, SPACE HEATING, etc.). The energy types shown are those that you have specified with the ELEC-METER, FUEL-METER, STEAM-METER, and CHW-METER commands in PLANT. The categories of use (also called energy end uses) are defined under the description of Report PS-E.

BEPU**BUILDING ENERGY PERFORMANCE**

This report is identical to the BEPS report, except that the end use breakdown for each of the energy types is given in the actual units of consumption, such as kWh or therms. In addition, the total site energy consumption (TOTAL ELECTRICITY, TOTAL NATURAL-GAS, etc.) is given for each energy type. Note that report PS-A groups heat rejection energy with cooling, while BEPS, BEPU, PS-E, and PS-F report heat rejection energy as a separate category.

REPORT-FREQUENCY

Allows you to control the frequency at which SYSTEMS hourly reports are printed. REPORT-FREQUENCY = HOURLY (the default) generates reports with hourly values. Also printed are summary values (minimum, maximum, total, and average) at the end of each day and month, and at the end of the run period specified in HOURLY-REPORT:REPORT-SCHEDULE. When REPORT-FREQUENCY = DAILY, the hourly data are suppressed and only summary values are printed for each day and at the end of the month and run period. Similarly, when REPORT-FREQUENCY = MONTHLY, only the summary statistics for months and the run period are printed. REPORT-FREQUENCY = YEARLY results in a single summary report covering the entire run period. Only scheduled hours are included in the summaries.

When REPORT-FREQUENCY is used in conjunction with the HOURLY-REPORT:OPTION = PLOT, only the total values are plotted. If REPORT-FREQUENCY is not specified, i.e., hourly data are printed, the plots are unchanged.

HOURLY-DATA-SAVE

Unused in the PLANT-REPORT command; if hourly data files from the HVAC simulation are desired this keyword should be specified in the SYSTEMS-REPORT command.

PV-MODULE

This command specifies the performance characteristics of a single photovoltaic module. The ELEC-GENERATOR component references this command, and builds up a system out of an array of modules and one or more inverters.

This algorithm calculates the plane-of-array irradiance on the module on an hourly basis as a function of the module orientation, sun angle, and weather data. The power output of the module is a function of the plane-of-array irradiance, ambient temperature, wind speed, and module characteristics.

Table 45 summarizes the units for both inverters and PV-MODULEs. Note that, for a PV-MODULE, most performance data other than physical dimensions are reported by the manufacturers only in metric units. For this reason, most of the module input is in metric; module dimensions and mounting height are English or metric consistent with the rest of the input.

The Sandia Laboratory in Los Alamos, New Mexico, USA maintains a database of PV modules that may be downloaded from their website. For convenience, the variable names used in that database are included in DOE-2 as the abbreviations to corresponding keywords. Where these variables exist, the Sandia abbreviation is identified using the format (Sandia database: 'xxx')

TYPE

accepts a code-word specifying the type of semiconductor material in the module. The program uses this information to select the appropriate performance curves for optical effects. This is a mandatory entry.

EFG-SI	specifies Silicon using an edge-defined film-fed growth ribbon process.
MC-SI	specifies a multi-crystalline silicon semiconductor.
SI-FILM	specifies Silicon deposited directly onto a ceramic substrate.
CD-TE	specifies a cadmium-telluride semiconductor.
A-SI	specifies an amorphous silicon semiconductor.
USER-SPECIFIED	specifies a user-defined semiconductor. In this case, the program requires you to specify the IRRADIANCE-FAM curve; this curve modifies the spectral properties of the plane-of-array irradiance as a function of air mass.

SIM-ALGORITHM

accepts a code-word specifying the temperature performance algorithm. This is a mandatory entry.

MODIFIED-STANDARD	specifies the standard model, modified to better account for irradiation and cell temperature.
SANDIA/KING	specifies that a more accurate algorithm formulated by David King at Sandia Laboratories - has advantage of higher accuracy at lower radiation models. Note that most manufacturers do not currently publish all of the necessary data to use this algorithm, and the program currently does not have any defaults for the additional data. However, Sandia maintains a database of PV modules that may be downloaded from their website.

As an aid in translating the Sandia data to DOE-2, the Sandia variable names are

used as DOE-2 keyword abbreviations, and are identified using the format “(Sandia database: xxx)”. You may enter either the DOE-2 keyword name, or the Sandia database variable name.

HEIGHT

specifies the height of the module, including the framing

WIDTH

specifies the width of the module, including the framing.

GLAZING-TYPE

accepts a code-word specifying the type of glazing material. The program selects the appropriate IRRADIANCE-FAOI curve based on this keyword:

SMOOTH	the default for all modules except amorphous silicon, specifies a smooth glazing surface.
STIPPLED	the default for amorphous silicon, specifies a stippled outer surface. The reflectivity of this glazing is less sensitive to the angle of incidence than smooth glazing.

The specification of this keyword must be consistent with the other parameters specified by the manufacturer. For example, while a stippled surface is less sensitive to the angle of incidence, it may not transmit quite as much irradiance as a clear glazing when the sun is directly normal to the surface. Therefore, the GLAZING-TYPE cannot be changed independently of other parameters such as the AMPS-MAX-PWR.

IRRADIANCE-FAM

accepts the U-name of a curve that modifies the spectral properties of the plane-of-array irradiation as a function of the effective air mass between the module and the sun. At lower sun angles, solar radiation passes through a greater thickness of air, which causes the spectrum to shift toward the red frequencies.

The default varies according to the TYPE of semiconductor, as different semiconductor materials are more responsive to certain frequencies than others. The maximum allowable air mass into the curve is 6.5

The Sandia database lists five coefficients, corresponding to a fourth-order curve. However, DOE-2's CURVE-FIT command only accepts cubics or lower. If you wish to use the Sandia coefficients directly, you may enter them via the keyword list A0-A4. The use of A0-A4 will override IRRADIANCE-FAM.

A0-A4

accepts a list in parenthesis of the five coefficients having the same name in the Sandia PV database. If specified, this 4th-order polynomial will be used in lieu of IRRADIANCE-FAM.

IRRADIANCE-FAOI

accepts the U-name of a curve that modifies the plane-of-array irradiation transmittance as a function of the sun's angle of incidence. Higher angles of incidence generally increase the reflectivity of the glazing surface, decreasing the net irradiation.

This curve is only used when the angle of incidence is greater than 40 degrees from perpendicular; there is no need to fit it for smaller angles. The default varies according to whether the GLAZING-TYPE is clear or stippled.

The Sandia PV database lists six coefficients, corresponding to a fifth-order curve. However, DOE-2's CURVE-FIT command only accepts cubics or lower. If you wish to use the Sandia coefficients directly, you may enter them via the keyword list B0-AB5. The use of B0-B5 will override IRRADIANCE-FAOI.

B0-B5

accepts a list in parenthesis of the six coefficients having the same name in the Sandia PV database. If specified, this 5th-order polynomial will be used in lieu of IRRADIANCE-FAOI.

CELL-BACK-DT

specifies the temperature difference between the cell and the back surface (Sandia database: 'DTC') at the reference irradiation of 1000 W/m². This entry is always in metric, °C.

VOLTS-OPEN-CKT

specifies the open circuit voltage (Sandia database: 'VOCO') at the reference conditions of 1000 W/m², 25°C cell temperature, and 1.5 air mass.

VOLTS/T-OPEN-CKT

specifies the rate at which the open circuit voltage changes with cell temperature (Sandia database: 'BVOCO') This entry is always in metric, Volts/°C. Some manufacturers list this value in units of %/°C. To convert to Volts/°C, multiply the value by VOLTS-OPEN-CKT/100.

AMPS-SHORT-CKT

specifies the short circuit current (Sandia database: 'ISCO') at the reference conditions of 1000 W/m², 25°C cell temperature, and 1.5 air mass.

AMPS/T-SHORT-CKT

specifies the rate at which the short circuit current changes with cell temperature (Sandia database: 'AISC') This entry is always in metric, 1/°C. Some manufacturers list this value in units of Amps/°C or %/°C. To convert Amps/°C to 1/°C, divide the value by AMPS-SHORT-CKT. To convert %/°C, divide the value by 100.

VOLTS-MAX-PWR

specifies the voltage at the maximum power point (Sandia database: 'VMPO') at the reference conditions of 1000 W/m², 25°C cell temperature, and 1.5 air mass. This value is always less than the open circuit voltage.

The maximum power point is the amperage/voltage condition that produces the maximum power output. If amperage is increased above this value, then the voltage decreases, as does the net power output (due to resistance losses). Similarly, if amperage is decreased below this point, then the voltage increases, but not enough to offset the decrease in amperage. Many inverters are designed to optimize their amperage draw over a broad range of irradiance so that the photovoltaic cells can output as much power as possible; DOE-2 does not currently simulate inverters that run at a fixed, non-optimal input voltage.

AMPS-MAX-PWR

specifies the current at the maximum power point (Sandia database: 'IMPO') at the reference conditions of 1000 W/m², 25°C cell temperature, and 1.5 air mass. This value is always less than the short circuit current.

The maximum power point is the amperage/voltage condition that produces the maximum power output. If amperage is increased above this value, then the voltage decreases, as does the net power output (due to resistance losses). Similarly, if amperage is decreased below this point, then the voltage increases, but not enough to offset the decrease in amperage. Many inverters are designed to optimize their amperage draw over a broad range of irradiance so that the photovoltaic cells can output as much power as possible; DOE-2 does not currently simulate inverters that run at a fixed, non-optimal input voltage.

COST-DATA

accepts the U-name of a MATERIALS-COST command that allows costs to be assigned to this component.

EQUIPMENT-REPORT

When YES, outputs a PS-H report for this component.

Sandia/King Algorithm

For the SANDIA/KING algorithm only, the next set of inputs specify additional information required. Currently, not all of this information is available from manufacturers, but may be found in the database maintained by Sandia Laboratories.

VOLTS/T-MAX-PWR

specifies the rate at which the maximum power point voltage changes with cell temperature (Sandia database: 'BVMPO') at the reference irradiance level of 1000W/m². This entry is always in metric, Volts/°C. Some manufacturers list this value in units of %/°C. To convert to Volts/°C, multiply the value by VOLTS-MAX-PWR/100.

VOLTS/E-MAX-PWR

specifies the correction to VOLTS/T-MAX-PWR for irradiance levels other than 1000W/m² (Sandia database: 'MBVMP'). This entry is always in metric, Volts/°C.

AMPS/T-MAX-PWR

specifies the rate at which the maximum power point current changes with cell temperature (Sandia database: 'AIMP'). This entry is always in metric, 1/°C. Some manufacturers list this value in units of Amps/°C or %/°C. To convert Amps/°C to 1/°C, divide the value by AMPS-MAX-PWR. To convert %/°C, divide the value by 100.

CELLS-SERIES

specifies the number of cells in series within the module.

C0

specifies the C0 coefficient in the Sandia/King equations (dimensionless).

C1

specifies the C1 coefficient in the Sandia/King equations (dimensionless).

C2

specifies the C2 coefficient in the Sandia/King equations (dimensionless).

C3

specifies the C3 coefficient in the Sandia/King equations (1/Volts).

FDIODE

specifies the diode-effect coefficient (Sandia database: 'N') in the King equations (dimensionless).

These values are used in the following equations:

$$E_{eff} = E_{poa} / 1000$$

$$dT_{ref} = T_{cell} - 25.$$

$$\begin{aligned} I_{mp} &= \text{AMPS-MAX-PWR} \\ &+ (C0 * E_{eff} + C1 * E_{eff}^2) * (1 + \text{AMPS/T-MAX-PWR} * dT_{ref}) \\ dT_c &= 0.000086173 * \text{FDIODE} * (T_{cell} + 273.15) \\ bV_{mp} &= \text{VOLTS/T-MAX-PWR} + \text{VOLTS/E-MAX-PWR} * (1 - E_{eff}) \\ V_{mp} &= \text{VOLTS-MAX-PWR} \\ &+ C2 * \text{CELLS-SERIES} * (dT_c * \ln(E_{eff})) \\ &+ C3 * \text{CELLS-SERIES} * (dT_c * \ln(E_{eff}))^2 \\ &+ bV_{mp} * dT_{ref} \end{aligned}$$

where

$$\begin{aligned} E_{eff} &= \text{the effective irradiance, hourly irradiance/reference (suns)} \\ T_{cell} &= \text{the hourly cell temperature (}^\circ\text{C)} \\ dT_{ref} &= \text{differential between hourly cell temperature and reference (}^\circ\text{C)} \\ I_{mp} &= \text{the current at the maximum power point (amps)} \\ dT_c &= \text{correction factor for the diode effect and temperature (Volts/cell)} \\ bV_{mp} &= \text{voltage correction factor for temperature and irradiance (Volts/}^\circ\text{C)} \\ V_{mp} &= \text{the voltage at the maximum power point} \end{aligned}$$

Module Reference Conditions

When the photovoltaic algorithms were first implemented, the standard rating conditions were somewhat inconsistent, and keywords were provided to allow a module to be specified at other conditions (NOM-OPER-CELL-T, NOCT-AMBIENT, NOCT-IRRADIANCE, NOCT-WINDSPEED, and REF-IRRADIANCE). Ratings are now standardized to 1000 W/m² irradiance and 25°C cell temperature, so it is no longer necessary to specify the rating conditions.

Expression Values

The next set of inputs are calculated by BDL expressions for use in other expressions, and are made available to you for informational purposes only. Do not override these values.

AREA

specifies the gross area of the module.

CAPACITY

specifies the direct-current power at the rated irradiance.

EFFICIENCY

specifies the efficiency of the module in converting solar irradiation to electrical power.

PUMP

Defines the operating parameters of a pump. U-name is required. The pump attaches to a CIRCULATION-LOOP or a piece of primary equipment (such as a chiller) by referencing the pump's U-name in the CIRCULATION-LOOP or primary equipment command. A unique pump must be defined for each application. In other words, a pump U-name can be referenced by only one CIRCULATION-LOOP or by one piece of primary equipment. Multiple references to the same pump will result in an error.

Example input:

```
"CHW pump" = PUMP ..
```

FLOW

The design flow of the pump, per pump. If not specified, the flow will default to the design loop flow, divided by the number of pumps.

NUMBER

The number of identical pumps attached to a loop. Multiple pumps will stage as required by the current loop flow and head.

HEAD

The design pressure rise across the pump when the pump is running. The default is the sum of the maximum head of any demander on the circulation loop (coils, etc.), the maximum head of any supplier to the circulation loop (boilers, chillers, etc.) and the loop head loss, with the sum adjusted by HEAD-RATIO. The program calculates the pump's design power consumption using this value together with the fluid flow rate, fluid properties, impeller efficiency and motor efficiency.

HEAD-RATIO

The oversizing ratio for the pump head when default sizing occurs.

HEAD-SETPT

The same as HEAD-SETPT for the CIRCULATION-LOOP and defaults to that value. When individual pumps are attached to the supply side of the equipment attached to a loop, and no loop pump is specified (i.e., the equipment-recirculation pumps are powering the loop), this keyword allows you to specify a separate setpoint for each of the active pumps. This is useful only when the pumps have different heads because the heads of their associated equipment units are different. Normally, you should let this keyword default.

HEAD-SETPT-RATIO

The same as HEAD-SETPT-RATIO for the CIRCULATION-LOOP and defaults to that value. As with HEAD-SETPT for the PUMP, this keyword allows pumps to have varying setpoints when pumps are attached to individual equipment units that are powering the loop. Normally, you should let this keyword default.

MECH-EFF

The impeller efficiency of the pump.

MOTOR-EFF

The efficiency of the pump's motor. If not specified, the default is based on the nameplate power and the efficiency classification (MOTOR-CLASS) of the motor. The program assumes that the nameplate power is the brake power increased by 30% to ensure that the motor is not overloaded over the range of the pump curve. See Table 46.

Table 46 Default motor efficiencies

Brake Power		MOTOR-CLASS		
HP	kW	STANDARD	HI-EFF	PREMIUM
0.083	0.064	.490	.490	.490
0.125	0.096	.550	.550	.550
0.167	0.129	.600	.600	.600
0.250	0.193	.640	.640	.640
0.333	0.256	.660	.660	.660
0.500	0.385	.700	.760	.800
0.750	0.578	.720	.770	.840
1.0	0.770	.790	.825	.855
1.5	1.16	.800	.840	.855
2.5	1.93	.800	.840	.855
3.9	3.00	.810	.865	.875
6.9	5.31	.820	.875	.902
12.9	9.93	.850	.885	.917
17.9	13.8	.860	.910	.910
20.9	16.1	.870	.910	.924
29.9	23.0	.880	.917	.930
69.9	53.8	.890	.930	.941
139.9	107.7	.900	.941	.950
1,000,000	770,000	.910	.950	.962

MOTOR-CLASS

Takes a code-word that specifies the efficiency classification the motor. The program uses this keyword to determine the efficiency of the motor when MOTOR-EFF is not entered. See Table 46

- STANDARD A standard efficiency motor.
- HI-EFF A NEMA high-efficiency motor.
- PREMIUM A NEMA premium-efficiency motor.

PUMP-KW

The design power consumption of the pump. If entered, its value should be consistent with the values for the pump's head, flow, impeller efficiency and motor efficiency. If not consistent, the program will recalculate the impeller efficiency to force consistency.

CAP-CTRL

Accepts a code-word that defines how the pump modulates as the flow varies. When you specify NUMBER to be more than one, then the pumps will first stage according to the load and then modulate capacity according to the CAP-CTRL mode:

ONE-SPEED-PUMP	The pump rides its curve as the flow varies (2-way valves in at least one system are necessary for this to happen).
TWO-SPEED-PUMP	The pump can operate at two speeds. The low-speed is determined by MIN-SPEED. You should choose MIN-SPEED to match the actual low speed ratio of the pump, typically 0.67 or 0.5.
VAR-SPEED-PUMP	The pump has a variable frequency drive. The minimum pump speed is specified by MIN-SPEED. Note that a pump's speed is not usually proportional to flow; speed is a function of both the pump flow as well as the pump head requirement. If the pump head requirement does not fall off as the square of flow (for example, when the pump has a fixed head setpoint), then the pump will operate at a speed higher than it would otherwise.

Note that if the loop flow is zero for the entire hour, the pump will be off for the hour no matter what CAP-CTRL is. To force a pump to run during a no-load condition, either one or more coils must have a 3-way valve or the CIRCULATION-LOOP's LOOP-MIN-FLOW or LOOP-RECIRC-FLOW must be nonzero.

MIN-SPEED

The low speed of a 2-speed pump or the minimum speed of a variable-speed pump. For a 2-speed pump this value should match the low pump speed, typically either 0.67 or 0.5. When CAP-CTRL = VAR-SPEED-PUMP, it is possible that the pump may never run at the MIN-SPEED. This is because the program calculates the head requirement on an hourly basis and includes the hourly head in the calculation for pump speed. When a static head exists somewhere on the loop the pump may be forced to run at a relatively high speed to overcome the static head even in a no-flow situation.

PUMP-HEAD-FFLOW

Takes the U-name of a curve defining how the head of the pump varies with flow. Head and flow are both normalized to 1.0. This curve can be linear or quadratic, but not cubic. The default is Pump-Head-fFlow, which is representative of a pump with a typical curve. When using a variable-speed or 2-speed pump, the pump performance curves are "re-normalized" hourly to match the actual pump speed.

PUMP-HP-FFLOW

Takes the U-name of a curve that defines how the pump power varies with flow. The default is representative of a pump with a flat curve. When using a variable-speed or 2-speed pump, the pump performance curves are "re-normalized" hourly to match the actual pump speed.

PUMP-MAX-RATIO

The maximum pump flow divided by the design flow. A pump can often move significantly more fluid than the design volume provided the head is lower than design. This situation commonly occurs when two (or more) pumps are used in parallel. When both pumps are operating each pump moves its design flow at the design head. When only one pump is running the loop flow and loop head are reduced. The reduced head allows the remaining pump to move more than its design flow. The maximum flow of the pump is limited by this keyword. Note that if PUMP-MAX-RATIO is too large, the maximum flow may correspond to a negative head.

PUMP-POWER-EXP

Specifies how the pump power varies with speed when all other parameters obey the ideal pump laws. If the pump were ideal, the exponent would be 3.0. The default accounts for non-ideal performance within the pump itself. This exponent should not be adjusted to account for the effects of non-ideal factors external to the pump, such as head pressure control; the program accounts for those factors separately. (Many designers assume that the actual horsepower exponent is in the range of 2.0 to 2.5, which approximates the effect of a fixed head pressure setpoint.) It is strongly recommended that you not change this parameter, as it will suffice for most pumps.

VFD-LOSS

When CAP-CTRL = VAR-SPEED-PUMP, accepts a value that represents the fraction of VFD drive losses expressed as a fraction of full load pump kW. The net load on the electric meter, at pump full load, will be the sum of the two values.

For example, if the pump kW is 40 and VFD-LOSS is 0.05, then the full-load drive loss is 2 kW, and the net load on the meter is 42 kW.

VFD-LOSS-FPLR

When CAP-CTRL = VAR-SPEED-PUMP, accepts the Uname of a CURVE-FIT command that is used hourly to modify (as a multiplier on) VFD-LOSS. The independent input to the curve is the current hour power output fraction calculated as (current hour motor kW)/(Design motor kW).

Extending the above example, if the pump motor is currently drawing 24 kW, then the part-load ratio on the drive is $24/40 = 0.60$. If feeding this value into the VFD-LOSS-FPLR curve yields a value of 0.73, then the drive loss is $2 \text{ kW} * 0.73 = 1.46 \text{ kW}$, and the net load on the meter is 25.46 kW.

ELEC-METER

Takes the U-name of an ELEC-METER command. The pump electricity is provided by this meter. If not specified, the default is the meter specified by AUX-ELEC-METER in the MASTER-METER command.

EQUIPMENT-REPORTS

When report PS-H of the PLANT-REPORTS is enabled, a report will print for this pump unless this keyword is set to NO.

COST-DATA

Takes the U-name of a MATERIALS-COST command, which allows you to define first costs, maintenance costs, etc. for this pump.

STEAM-METER

Defines the parameters for a meter that supplies steam from a utility. This meter attaches to a loop and provides the required heating to the loop. The meter may meet all of the load (no other heating equipment attached to the loop), or be coordinated with other primary equipment to provide only part of the load. The program passes the meter consumption data to the ECONOMICS program so that costs can be determined.

Rules:

Multiple STEAM-METERS may be defined.

Any given loop can have at most one STEAM-METER attached to it. A 2-pipe loop may have a CHW-METER and a STEAM-METER attached to it.

If you define a UTILITY-RATE of TYPE=STEAM, but do not list the meters, the default will be all meters of the correct type.

A meter may be the sole source of energy to a CIRCULATION-LOOP, or there may also be other equipment (boilers, chillers, etc.) By default, the program will allocate as much of the loop load to the primary equipment as possible, with the meter making up the remainder. You can override this default control sequence by defining an EQUIP-CTRL sequence for the loop.

CIRCULATION-LOOP

Takes the U-name of the CIRCULATION-LOOP to which this meter is attached. The CIRCULATION-LOOP must be of TYPE = HW, WLHP or PIPE2.

CAPACITY

The size of the meter service. The program assumes that the capacity of the meter is limited by the piping serving the site, and that any loads larger than this capacity will result in an overload condition. If you do not specify this keyword, the capacity will default to the loop capacity, adjusted by the CAPACITY-RATIO. If no CAPACITY-RATIO is input, then the capacity will default to the loop capacity.

CAPACITY-RATIO

If CAPACITY is not entered, this is the fraction of the design loop capacity that the meter will be sized to meet.

ENERGY/UNIT

The size of the billing unit in which consumption is measured.

UNIT-INDEX

An integer value that defines the billing unit as listed in the units table (Appendix A). This value is used in the reports, and allows English units to be converted to the correct metric units. The default corresponds to MBtu in English units and MWh in metric units.

DEM-UNIT-INDEX

An integer value that defines the billing unit of peak demand as listed in the units table (Appendix A). This value is used in the reports, and allows English units to be converted to the correct metric units. The default corresponds to MBtu/hr in English units and MW in metric units.

SOURCE-SITE-EFF

The ratio between source energy (the energy used by the utility to generate the energy delivered to the building) and the energy delivered to the building.

INTERIOR-POWER

Accepts a list of up to 5 values of hourly energy consumed by miscellaneous uses inside the building that do not show up anywhere else. This energy shows up as a load on the meter, but does not appear as either a space load or as a circulation loop load. Note that most process loads should be entered as such on a CIRCULATION-LOOP, rather than here. This is so that the program can account for thermal losses and pumping energy. Use INTERIOR-SCH, below, to schedule interior power.

INTERIOR-SCH

Accepts a list of up to 5 U-Names of schedules with TYPE = MULTIPLIER that modify the INTERIOR-POWER values on an hourly basis.

INTERIOR-EU

Accepts a list of up to 10 code-words specifying the end-use category of the INTERIOR-POWER. The code-words correspond to the end-use categories in the end-use reports (PS-E, PS-F, BEPS, BEPU). Acceptable entries are LIGHTS, TASK-LIGHTS, MISC-EQUIP, SPACE-HEATING, SPACE-COOLING, HEAT-REJECT, PUMPS&AUX, VENT-FANS, REFRIG-DISPLAY, HT-PUMP-SUPPLEM, DOMEST-HOT-WTR, and EXT-USAGE.

Note that, while exterior energy can be entered via the EXTERIOR-POWER keyword, it may also be entered via the INTERIOR-POWER and INTERIOR-EU = EXT-USAGE keywords.

EXTERIOR-POWER

Accepts a list of up to 5 values of hourly energy consumed by miscellaneous uses outside the building that do not show up anywhere else. This energy shows up as a load on the meter, but does not appear as either a space load or as a circulation loop load. Note that most process loads should be entered as such on a CIRCULATION-LOOP, rather than here. This is so that the program can account for thermal losses and pumping energy .

EXTERIOR-SCH

Accepts a list of up to 5 U-Names of schedules with TYPE = MULTIPLIER that modify the EXTERIOR-POWER values on an hourly basis.

EXTERIOR-EU

Accepts a list of up to 10 code-words specifying the end-use category of the EXTERIOR-POWER. The code-words correspond to the end-use categories in the end-use reports (PS-E, PS-F, BEPS, BEPU, TDV1 TDV2). Acceptable entries are LIGHTS, TASK-LIGHTS, MISC-EQUIP, SPACE-HEATING, SPACE-COOLING, HEAT-REJECT, PUMPS&AUX, VENT-FANS, REFRIG-DISPLAY, HT-PUMP-SUPPLEM, DOMEST-HOT-WTR, and EXT-USAGE.

Note that, while exterior energy can be entered via the EXTERIOR-POWER keyword, it may also be entered via the INTERIOR-POWER and INTERIOR-EU = EXT-USAGE keywords.

HX-HEAD

The pressure drop through the meter's heat-exchanger, if one exists. The default value assumes that a steam to hot-water heat-exchanger exists. The heat-exchanger head affects the overall head requirement of the loop.

HX-STATIC-HEAD

Accepts a numeric input defining the static head that the meter creates on the loop (non-varying with flow). Normally, this value will be zero for virtually all systems.

METER-REPORT

Takes the code-words YES or NO. The default is YES. When report PS-F of the PLANT-REPORTS is enabled, a report will print for this meter unless this keyword is set to NO.

SUBR-FUNCTIONS

Allows input functions to be executed in user-specified subroutines in the HVAC (SYSTEMS and PLANT) program. The keywords under SUBR-FUNCTIONS are named after SYSTEMS and PLANT subroutines. These keywords take only one U-name (that of a function) surrounded by asterisks, but without parentheses; for example, RESYS-1Z = *RESFN-1*. See "Input Functions" in the *DOE-2.2 Topics*.

Example input:

```

SUBR-FUNCTIONS
  FCOIL-0           = *FN0*
  FCOIL-1Z         = *FN1*
  FCOIL-3           = *FN3*  ..

.....

END ..

FUNCTION
  NAME              = FN0
  .....
  END-FUNCTION     ..

FUNCTION
  NAME              = FN1
  .....
  END-FUNCTION     ..

FUNCTION
  NAME              = FN3
  .....
  END-FUNCTION     ..

COMPUTE ..

```

SYSTEM

Specifies the data for a secondary HVAC distribution system. The information provided includes system type, size, zones served, optional components, operating schedules, temperature and humidity limits, control strategies, outside air requirements, and fan static pressures and efficiencies. U-name is required so that the SYSTEM can be identified in reports.

A SYSTEM command must precede the input for any ZONEs that belong to the system. This allows the program to determine zone default values that depend on system type.

Example input:

```
"Flr:1 Air Handler" = SYSTEM
  TYPE                = DDS
  HEAT-SOURCE         = HOT-WATER
  RETURN-AIR-PATH     = PLENUM-ZONES
  DDS-TYPE            = DUAL-FAN
  MAX-SUPPLY-T        = 120
  HEATING-SCHEDULE    = "Heat-Off Schedule"
  MIN-SUPPLY-T        = 60
  COOLING-SCHEDULE    = "Cool-Off Schedule"
  COOL-RESET-SCH     = "Cool Reset Sched"
  COOL-CONTROL        = RESET
  ECONO-LIMIT-T       = 65
  FAN-SCHEDULE        = "Fan Operation"
  FAN-CONTROL         = SPEED
  SUPPLY-STATIC       = 5.5
  SUPPLY-EFF          = 0.55
  NIGHT-CYCLE-CTRL    = CYCLE-ON-ANY
  MIN-FLOW-RATIO      = 0.3
  HW-LOOP             = "Heating Loop"
  PHW-LOOP            = "Heating Loop"
  CHW-LOOP            = "Cooling Loop"
  ..
```

TYPE

Takes a code-word that identifies the type of system to be simulated. Table 47 shows the system types allowed by the program.

DDS-TYPE

For TYPE = DDS, MZS or PMZS, takes a code-word that specifies the type of dual-duct system. Allowed values are:

SINGLE-FAN	Single-fan dual-duct system.
DUAL-FAN	Dual-fan dual-duct system. Note that, while multizone systems are typically single-fan blow-through systems, they can be specified as dual-fan so that dual-fan dual-duct systems built up from packaged equipment can be simulated.

Table 47 Airside system types

Category	Code-word	Description
Single Supply Duct	SZRH	Variable Temperature
	PSZ	Packaged Single-zone
	SZCI	Ceiling Induction
	RHFS	Constant-volume Reheat Fan
	VAVS	Variable-volume Fan
	PIU	Powered Induction Unit
	PVAVS	Packaged Variable Air Volume
	PVVT	Packaged Variable-Volume, Variable-Temperature
	CBVAV	Ceiling Bypass
	EVAP-COOL	Evaporative Cooling
Air Mixing	MZS	Multizone Fan
	PMZS	Packaged Multizone
	DDS	Dual-duct Fan
	FC	Fan Coil
Terminal Unit	IU	Induction Unit
	PTAC	Packaged Terminal Air Conditioner
	HP	Water Loop Heat Pump
Residential	RESYS	Residential with cycling furnace and cycling air-conditioner
	RESYS2	Residential with cycling furnace and cycling air-conditioner
	RESVVT	Residential Variable-Volume, Variable-Temperature
Heating Only	FPH	Floor Panel Heating
	HVSY	Heating and Ventilating
	UHT	Unit Heater
	UVT	Unit Ventilator
Diagnostics	SUM	Sum Zone Loads
User-Defined	FNSYS1	Defined using Input Functions

SIZING-OPTION

Takes a code-word that specifies whether the system's SUPPLY-FLOW equals the sum of the zone flows (NON-COINCIDENT) or is based on the peak block load (COINCIDENT). The reason that NON-COINCIDENT is the default is due to the reduced lighting power and better window treatment that most designers use today. If the number of hours with "loads not met" is too high with SIZING-OPTION = NON-COINCIDENT, you should increase the air-side system capacity by setting SIZING-RATIO > 1.0.

NON-COINCIDENT SUPPLY-FLOW is sized using the sum of the peak loads of the individual zones. (These peaks usually occur at different times and are, therefore, non-coincident.)

COINCIDENT

SUPPLY-FLOW is sized using the peak value of the sum of the loads of the zones on the system.

SIZING-RATIO

Multiplier on the program-calculated values of air flow rate and coil size. This keyword is used to deliberately oversize or undersize the equipment in the system. The input for this keyword is the desired capacity of the system divided by either (1) the capacity you assign in the secondary systems input or (2) the capacity calculated by the program from peak loads. SIZING-RATIO does not modify the heating/cooling loads calculated in LOADS. It modifies the secondary equipment sizes only, not the primary equipment sizes. Using SIZING-RATIO will probably change the responsiveness of the system, making it faster or slower depending on whether you oversize or undersize the equipment. Modifying the size of the system equipment can also change the demands placed on the primary equipment, resulting in undersized or oversized primary equipment.

Air Flow and Fans

The following keywords provide information on system supply air flow rates, fan power , and fan control. All air quantities should be input as sea level (standard) values because the program makes a correction for altitude. Input of air quantities corrected for altitude above sea level will result in a double correction.

In the case of a zonal system, the keywords apply to *each* zone. For example, if the SUPPLY-FLOW is 2000 cfm, then each zone is assumed to receive 2000 cfm. For central systems, the keywords apply to the central system; flows, etc. may be further broken down at the ZONE level.

The same type of information is provided for exhaust fans, if any, at the zone level (keywords EXHAUST-FLOW, EXHAUST-STATIC, etc., in ZONE)

Supply Fan

The following keywords define the supply fan serving any single-duct system, the cold deck of a dual-duct system, or a zonal system.

SUPPLY-FLOW

The design capacity (in standard, or sea level, flow) of the system's air supply fan. This entry is usually omitted, unless fan capacity is a known value and different from the air flow rates calculated by the program . The program calculates the default from zone loads and ZONE command input.

You will improve the simulation accuracy for existing buildings by inputting known system SUPPLY-FLOW. For stand-alone evaporative coolers, you must precalculate SUPPLY-FLOW since the program's HVAC design calculations do not apply to evaporative cooling.

The program proportions the specified total supply air into zone air quantities as follows:

Adjusted Zone Air Flow =

$$\left(\frac{< SUPPLY - FLOW >}{(\text{Sum of Calculated Zone Air Flows})} \right) * (\text{Calculated Zone Air Flow})$$

Your inputs of ZONE-level ASSIGNED-FLOW and EXHAUST-FLOW replace the other "Calculated Zone Air Flows" in the summation (but only when the latter exceeds the calculated zone flow). When you allow the program to calculate MIN-FLOW-RATIO (rather than input it), the values for Minimum Flow Ratio (see SV-A report) are corrected relative to the values of "Adjusted Zone Air Flow" taking into account the specified outside/exhaust air or the peak heating load. Likewise, your input of MIN-OUTSIDE-AIR would result in new quantities of Outside Air

Flow (see SV-A report) since these values would simply be the ratio of the zone flow rate and the SUPPLY-FLOW value times the MIN-OUTSIDE-AIR value.

SIZING-METHOD

DEFAULT

The program calculates the cooling capacity and supply airflow, but does not explicitly link one to the other. Note that the user may specify either the COOLING-CAPACITY or the SUPPLY-FLOW to override the default calculation

FLOW/CAPACITY

The program calculates the default cooling capacity, and uses it to set the supply airflow. If the user specifies the COOLING-CAPACITY, this value will be used to set the airflow.

CAPACITY/FLOW

The program calculates the default supply airflow, and uses it to set the cooling capacity. If the user specifies the SUPPLY-FLOW, this value will be used to set the cooling capacity.

FLOW/CAPACITY

when SIZING-METHOD = FLOW/CAPACITY or CAPACITY/FLOW, is the ratio of the SUPPLY-FLOW to the COOLING-CAPACITY. If you do not specify this value, the program will assume a range of values are acceptable, as specified by the MAX-FLOW/CAPACITY and MIN-FLOW/CAPACITY limits.

MIN-FLOW/CAPACITY

when SIZING-METHOD = FLOW/CAPACITY or CAPACITY/FLOW, and the FLOW/CAPACITY ratio is not specified, defines the lower limit of the range of flow per capacity values. The program will independently calculate the COOLING-CAPACITY and the SUPPLY-FLOW, but then apply this limit.

For example, assume the SIZING-METHOD is FLOW/CAPACITY, and the MIN-FLOW/CAPACITY and MAX-FLOW/CAPACITY are 350 and 500 cfm/ton respectively. The program determines the COOLING-CAPACITY is 120,000 Btuh, or 10 tons. If the default airflow is 4000 cfm, then the cfm/ton ratio = $4000/10 = 400$ cfm/ton, which is within the allowed range. In this case the default airflow will not be overridden. If instead the default airflow is 3000 cfm, this corresponds to 300 cfm/ton which is below the minimum allowed limit of 350 cfm/ton. The program will override the default airflow to be $10 \text{ tons} * 350 \text{ cfm/ton} = 3500 \text{ cfm}$.

MAX-FLOW/CAPACITY

when SIZING-METHOD = FLOW/CAPACITY or CAPACITY/FLOW, and the FLOW/CAPACITY ratio is not specified, defines the upper limit of the range of flow per capacity values. The program will independently calculate the COOLING-CAPACITY and the SUPPLY-FLOW, but then apply this limit.

For example, assume the SIZING-METHOD is FLOW/CAPACITY, and the MIN-FLOW/CAPACITY and MAX-FLOW/CAPACITY are 350 and 500 cfm/ton respectively. The program determines the COOLING-CAPACITY is 120,000 Btuh, or 10 tons. If the default airflow is 4000 cfm, then the cfm/ton ratio = $4000/10 = 400$ cfm/ton, which is within the allowed range. In this case the default airflow will not be overridden. If instead the default airflow is 6000 cfm, this corresponds to 600 cfm/ton which is above the maximum allowed limit of 500 cfm/ton. The program will override the default airflow to be $10 \text{ tons} * 500 \text{ cfm/ton} = 5000 \text{ cfm}$.

SUPPLY-STATIC

Total static pressure of the supply fan at design flow rate. Pressure losses should include filters, coils, fan housing, and distribution system. Use either SUPPLY-STATIC and SUPPLY-EFF or SUPPLY-DELTA-T and SUPPLY-KW/FLOW.

SUPPLY-EFF

Overall efficiency of the supply fan, motor and drive. Use either SUPPLY-STATIC and SUPPLY-EFF or SUPPLY-DELTA-T and SUPPLY-KW/FLOW.

SUPPLY-DELTA-T

Temperature rise in the air stream across the supply fan. Use either SUPPLY-STATIC and SUPPLY-EFF or SUPPLY-DELTA-T and SUPPLY-KW/FLOW. The default is the SUPPLY-KW/FLOW * 3090.

SUPPLY-KW/FLOW

Design full-load power of the supply fan per unit of supply air flow rate at sea level. Use either SUPPLY-STATIC and SUPPLY-EFF or SUPPLY-DELTA-T and SUPPLY-KW/FLOW. Used in conjunction with SUPPLY-DELTA-T. For systems for which the FAN-PLACEMENT can be specified, and the placement is BLOW-THROUGH, the default value is increased by a factor of 1.11

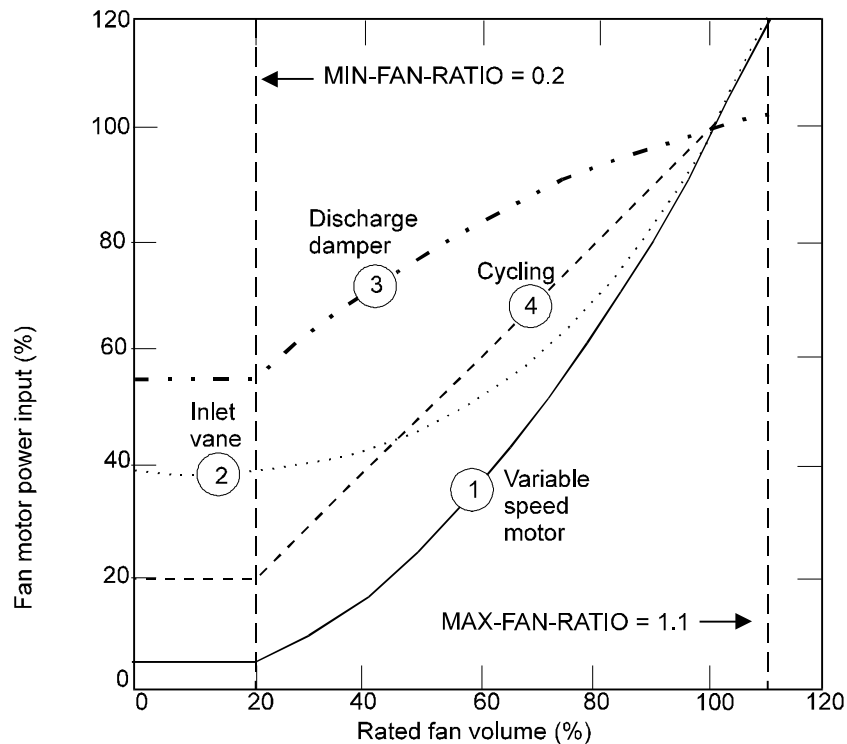

Figure 37 Typical power requirements at part-load operation for four different methods of air flow control. Note that for FAN-CONTROL = CYCLING, MIN-FAN-RATIO is meaningless when the fan is off.

SUPPLY-MECH-EFF

The mechanical efficiency of the supply fan. The difference between SUPPLY-EFF and this value is assumed to be due to motor and drive losses. SUPPLY-MECH-EFF is used in conjunction with SUPPLY-STATIC and SUPPLY-EFF to specify the mechanical efficiency of the fan when the motor is located outside the air stream. The SYSTEMS program separates the total fan efficiency into its mechanical and electrical components. The mechanical energy loss of the fan is always added to the air stream. The electrical energy loss of the fan is added to the air stream only if the fan motor is located inside the air stream.

For systems in which the FAN-PLACEMENT can be specified, and the placement is BLOW-THROUGH, the program adjusts the default mechanical efficiency by 0.89 times its DRAW-THROUGH value.

MOTOR-PLACEMENT

Takes a code-word that specifies whether the supply and return fan motors are located inside the air stream or outside the air stream. The SYSTEMS program uses this information to determine if the heat loss of the motors is to be added to the supply and return air streams. Applies only to systems SZRH, MZS, DDS, SZCI, TPIU, FPIU, VAVS, RHFS, HVSYS, CBVAV, PSZ, PMZS, PVAVS, and RESYS2.

IN-AIRFLOW	The fan motor is located inside the duct or air stream.
OUTSIDE-AIRFLOW	The fan motor is located outside the duct or air stream.

FAN-PLACEMENT

Takes a code-word that specifies whether the supply fan is a draw-through type fan or a blow-through type fan (i.e., whether the fan placed downstream or upstream of the central cooling/heating coils). Applies to systems SZRH, SZCI, TPIU, FPIU, VAVS, RHFS, CBVAV, PSZ, and PVAVS.

BLOW-THROUGH	The supply fan is located upstream of the central heating/cooling coils and blows the air through the coils. Use of this code-word causes the program to add the supply fan heat to the air upstream of the central cooling/heating coils. Always used for DDS (single fan), UHT, UVT, PTAC, PMZS, TPFC, FPFC, HP, RESYS, RESYS2 and MZS systems
DRAW-THROUGH	The supply fan is located downstream of the central heating/cooling coils and draws the air through the coils. Use of this code-word causes the program to add the supply fan heat to the air downstream of the central cooling/heating coils. This is the default for SZRH, SZCI, TPIU, FPIU, VAVS, RHFS, CBVAV, PSZ, and PVAVS, provided heat is not provided by a furnace. If heat is provided by a furnace, the default is BLOW-THROUGH.

MAX-FAN-RATIO

Maximum air flow through the supply fan, expressed as a fraction of the design flow rate.

MIN-FAN-RATIO

Minimum air flow through the supply fan (not through the system), expressed as a fraction of the design flow rate. When a variable air volume system requires less air flow, a fan bypass is utilized.

FAN-CONTROL

Takes a code-word that specifies the type of air flow reduction control. The program calculates the part-load power consumption of the supply fan and return fan (if any) using the fan power vs. part load characteristics corresponding to the control mode selected (Figure 37). The program assumes that both supply and return fans have the same kind of flow control. Allowed code words are:

SPEED	Control is by varying motor speed (Curve 1 in Figure 37).
INLET	Control is by varying the position of inlet vanes.
DISCHARGE	Control is by varying the position of discharge dampers or allowing the duct pressure to build behind the VAV box (Curve 3 in Figure 37).

CYCLING	Control is by cycling the fans on and off (Curve 4 in Figure 37). Used for SYSTEM:TYPE = RESYS and RESYS2.
TWO-SPEED	The fan has high- and low-speed settings.
CONSTANT-VOLUME	No air flow control. This is the default for all systems other than variable volume systems)
FAN-EIR-FPLR	Fan control method is user specified using the U-name of a curve as input to FAN-EIR-FPLR. See description of FAN-EIR-FPLR

FAN-EIR-FPLR

Takes the U-name of a linear, quadratic, or cubic curve that gives the ratio of fan electric energy to full-load fan electric energy, as a function of part-load ratio. If this keyword is used, then FAN-CONTROL should be set equal to FAN-EIR-FPLR (i.e., "FAN-EIR-FPLR" is both a keyword, which takes the U-name of a curve, and a code-word for the FAN-CONTROL keyword).

INDOOR-FAN-MODE

Takes a code-word that specifies how the indoor fan is controlled. Applicable to DX cooling system types PSZ, PVAVS, PVVT, RESYS and RESYS2 plus chilled water cooling systems types FC and SZRH.

CONTINUOUS	The indoor fan always runs when it is scheduled on by FAN-SCHEDULE or NIGHT-CYCLE-CTRL.
INTERMITTENT	The indoor fan operates as in CONTINUOUS, but only for that fraction of the hour required for space heating or cooling. This is the default for RESYS and RESYS2.

LOW-SPEED-RATIOS

Takes a list of four values that describe fan capacity, electric energy, heating capacity and cooling capacity, respectively, at low speed relative to the corresponding values at high speed. These values apply when SYSTEM:FAN-CONTROL = DUAL-SPEED for PTAC and SYSTEM:COMPRESSOR-TYPE = DUAL-SPEED for RESYS or RESYS2 (although the later case is better modeled using the SYSTEM:AIR/TEMP-CONTROL keyword.) The values are as follows:

- 1st = ratio of fan flow at low speed to that at high speed (for the PTAC case, 1.0 for other cases)
- 2nd = ratio of compressor EIR at low speed to that at high speed
- 3rd = ratio of heating capacity at low speed to that at high speed
- 4th = ratio of cooling capacity at low speed to that at high speed

Supply Fan, Hot Deck of Dual-Duct System

The following keywords apply to the hot deck of a dual-fan, dual-duct or multizone system.

HSUPPLY-FLOW

Same as SUPPLY-FLOW, except applies only to the heating fan when DDS-TYPE = DUAL-FAN. If not specified, the hot deck fan will be sized to meet the peak heating air flow rate. If all of the zone thermostats are REVERSE-ACTION, or the zone mixing boxes are constant-volume, then the hot-deck fan will be the same size as the cold-deck fan.

HSUPPLY-STATIC

Total static pressure of the hot-deck fan at design flow rate. Pressure losses should include filters, coils, fan housing, and distribution system.

HSUPPLY-EFF

the overall efficiency of the hot-deck fan, motor and drive. Use either HSUPPLY-STATIC and HSUPPLY-EFF or HSUPPLY-DELTA-T and HSUPPLY-KW/FLOW.

HSUPPLY-DT

For the hot-deck fan in a dual-fan dual-duct system (SYSTEM:DDS-TYPE = DUAL-FAN), the temperature rise in the air stream across the hot-deck fan. Use either HSUPPLY-STATIC and HSUPPLY-EFF or HSUPPLY-DELTA-T and HSUPPLY-KW/FLOW. The default will be HSUPPLY-KW/FLOW * 3090.

HSUPPLY-KW/FLOW

For the hot-deck fan in a dual-fan dual-duct system (SYSTEM:DDS-TYPE = DUAL-FAN), specifies the design full-load power of the fan per unit of air flow rate at sea level. Use either HSUPPLY-STATIC and HSUPPLY-EFF or HSUPPLY-DELTA-T and HSUPPLY-KW/FLOW.

HSUPPLY-MECH-EFF

The mechanical efficiency of the hot-deck fan in a dual-fan dual-duct system (SYSTEM:DDS-TYPE = DUAL-FAN). Used in conjunction with HSUPPLY-STATIC and HSUPPLY-EFF to specify the mechanical efficiency of the fan when the motor is located outside the air stream. The default mechanical efficiency will be multiplied by a factor of 0.89 if the HFAN-PLACEMENT = BLOW-THROUGH

HMOTOR-PLACEMENT

Same as MOTOR-PLACEMENT, except applies only to the hot-deck fan in a dual-fan dual-duct system (SYSTEM:DDS-TYPE = DUAL-FAN).

HFAN-PLACEMENT

Same as FAN-PLACEMENT, except applies only to the hot-deck fan in a dual-fan dual-duct system (SYSTEM:DDS-TYPE = DUAL-FAN). The default is DRAW-THROUGH, unless the HEAT-SOURCE = FURNACE, in which case it is BLOW-THROUGH.

HMAX-FAN-RATIO

Same as MAX-FAN-RATIO, except applies only to the hot-deck fan in a dual-fan dual-duct system (SYSTEM:DDS-TYPE = DUAL-FAN).

HMIN-FAN-RATIO

Same as MIN-FAN-RATIO, except applies only to the hot-deck fan in a dual-fan dual-duct system (SYSTEM:DDS-TYPE = DUAL-FAN).

HFAN-CONTROL

Same as FAN-CONTROL, but applies only to the hot-deck fan when SYSTEM:DDS-TYPE = DUAL-FAN. Otherwise, this keyword is unused. If not specified, the hot deck fan capacity control will default to that given by FAN-CONTROL.

HFAN-EIR-FPLR

Same as FAN-EIR-FPLR, except applies only to the hot-deck fan in a dual-fan dual-duct system (SYSTEM:DDS-TYPE = DUAL-FAN). Used in conjunction with HFAN-CONTROL = FAN-EIR-FPLR.

Return Fan and Exhaust

The following keywords define the properties of the return leg of the air distribution system. These keywords apply only to central systems

RETURN-AIR-PATH

Takes a code-word that describes the route that return air from the zones in the system takes in getting back to the air-handling/air-handling unit. This determines whether heat from lights and other sources will be added to the return air stream.

DIRECT	The return air flows back to the air-handler or relief point (central exhaust) via the zones, hallways or stairwells. All of the heat from lights that was specified in LOADS to go to the return air through the SPACE:LIGHT-TO-RETURN keyword will be added to the zone load.
DUCT	A fraction of the heat from lights, specified with the SPACE:LIGHT-TO-RETURN keyword in LOADS, is added to the return air stream. For a variable air volume system, this fraction is the ratio of the flow to the zone that hour to the maximum design flow to the zone. This code-word should be used in two cases: (1) when return air duct work actually exists in the building, and (2) when the return air passes through a plenum and the plenum is essentially at the same temperature as the zone it serves. The second case allows a great simplification of input for high-rise office buildings where there are plenum zones in the intermediate floors. You specify the conditioned spaces to be large enough to include the plenum areas and don't input a plenum at all. The heat from lights that goes to the plenum is specified by LIGHT-TO-RETURN keyword (not LIGHT-TO-OTHER). In the first case, if the return air ducts are located in an unconditioned zone, that zone should be identified in SYSTEMS as ZONE:TYPE = UNCONDITIONED.
PLENUM-ZONES	The return air path is through plenums. There is significant conduction to or from the return air across the plenum walls. Heat from lights can be added in two ways: through SPACE:LIGHT-TO-OTHER in LOADS and through SPACE:LIGHT-TO-RETURN. LIGHT-TO-OTHER allows some of the light heat to be stored in the plenum walls; LIGHT-TO-RETURN results in an instantaneous cooling load on the return air. Specify PLENUM-ZONES as the return air path if there are zones with SYSTEM:TYPE = PLENUM in the system.

The default for system types SZRH, MZS, IU, HVSY and PSZ is DIRECT. However, all systems that usually pick up heat from return-air-vented light fixtures default to DUCT, including RESYS2. Allowed values for RETURN-AIR-PATH are:

RETURN-FLOW

Design capacity (in standard, or sea level, flow) of the system's return air fan. Although the outside air flow may vary with time due to schedules or OA-CONTROL strategy, this flow is uninterrupted as long as the FAN-SCHEDULE is on for the hour, or if NIGHT-CYCLE-CTRL intervenes to turn the fans on when the FAN-SCHEDULE is off. The outside air flow is not determined by the space heating and cooling demands.

The default for RETURN-FLOW is calculated from ZONE input and zone loads. For stand-alone evaporative coolers, you must precalculate this value since the program's HVAC design calculations do not apply to evaporative cooling.

RETURN-FAN-CONTR

Takes a code-word that allows the capacity control mechanism of the return/relief fan to be specified independently of the supply fan. Used for all system types that allow a return fan to be specified. Takes the same code-words as SYSTEM:FAN-CONTROL; if not specified, operation defaults to that specified by FAN-CONTROL.

RETURN-STATIC

Total static pressure of the return air fan when operating at design flow rate (as given by RETURN-FLOW or as calculated). When there is no return fan the pressure loss in the return fan ducts should be added to the supply fan static. The return air fan defaults to the same type of variable-volume control as that assigned to the supply fan. Use either RETURN-STATIC and RETURN-EFF or RETURN-DELTA-T and RETURN-KW/FLOW. If neither RETURN-STATIC and RETURN-EFF nor RETURN-DELTA-T and RETURN-KW/FLOW are entered, the program assumes that the system has no return fan.

RETURN-EFF

Overall efficiency of the return fan, motor, and drive at design conditions. Use either RETURN-STATIC and RETURN-EFF or RETURN-DELTA-T and RETURN-KW/FLOW.

RETURN-DELTA-T

The temperature rise in the air stream across the return air fan. Use either RETURN-STATIC and RETURN-EFF or RETURN-DELTA-T and RETURN-KW/FLOW. The default will be the RETURN-KW/FLOW * 3090.

RETURN-KW/FLOW

The design full load power consumption of the return fan per unit of air flow at sea level. Use either RETURN-STATIC and RETURN-EFF or RETURN-DELTA-T and RETURN-KW/FLOW.

RETURN-FAN-LOC

Takes a code-word that specifies the location of the return fan, if present.

COMMON	The return fan is located in the main return air stream. For a dual-fan dual-duct system the fan is located in the main return air stream. It will operate whenever either the hot or cold deck fan is operating. For a single-fan system that is either single-duct or dual-duct, COMMON simulates a conventional return fan.
COLD-DECK-ONLY	For a dual-fan dual-duct system, the return fan serves only the cold deck, and the hot deck fan draws its air directly from the return ducting or plenum. In this configuration, the return fan operates only when the cold deck fan is also operating. This code-word is ignored for single-fan systems.
RELIEF	Applies to the case where a central exhaust fan operates to relieve any excess outdoor air brought in through the economizer and not exhausted through zone level exhaust fans. This option is applicable to all systems that may have a return fan. When using RELIEF, you should recognize that relief fans typically use less power than conventional return fans. Therefore, you should adjust the values of related keywords such as RETURN-KW/FLOW accordingly. On the other hand, the supply fan static pressure and power may increase when using a relief fan since a conventional return fan removes the burden of the return static pressure losses from the supply fan. The relief fan runs only when there is a surplus of air that must be exhausted. You need to verify whether one of the RETURN-FAN-CONTROL performance curves matches the actual performance of the relief fan and use RETURN-EIR-FPLR to define the performance if required. For multiple relief fans that are staged based on building pressurization or economizer position,

RETURN-FAN-CONTROL = CYCLING will simulate power consumption that is linear with relief air flow.

RETURN-CAP-RATIO

For systems that can have a return fan, specifies the ratio of the return/relief fan capacity to the supply capacity. Applies only when a return fan exists. In many buildings, the return fan is deliberately sized 10% to 20% smaller than the supply fan (RETURN-CAP-RATIO = 0.8 to 0.9) so that the building is pressurized whenever the fans run. The difference between the supply and return air flow exfiltrates from the building (or is exhausted through zone exhaust fans). The default value of 1.0 implies that no building pressurization occurs. The amount assumed to exfiltrate is

$$FX = [\text{SUPPLY-FLOW}] * (1.0 - [\text{RETURN-CAP-RATIO}])$$

In other words, the amount exfiltrated due to building pressurization (or zone exhaust) is assumed to be constant all hours of operation. In the hourly simulation, the return/relief fan operates only when the actual return air flow is greater than (FX - zonal exhaust). The return/relief fan moves only the amount of return air greater than FX. If FX is greater than the outside air ventilation requirements, as defined through other keywords, then FX will override any other outside air requirements including those specified through scheduled values. If you have specified the return fan size, a check will be made to see if any building pressurization is occurring. The difference between the supply flow and return flow is compared to the zonal exhaust quantity. If the zonal exhaust quantity is less than this difference, then the balance is assumed to exfiltrate. Note that infiltration is still assumed to occur, as infiltration is calculated in the LOADS module. For this reason, the infiltration schedules in LOADS should be coordinated with the fan schedules in SYSTEMS.

RETURN-EIR-FPLR

For the return fan of a multizone or dual-fan dual-duct system, takes the U-name of a linear, quadratic, or cubic curve that gives the ratio of return fan electric energy to full-load return fan electric energy, as a function of part-load ratio. This keyword must be specified if RETURN-FAN-CONTROL = FAN-EIR-FPLR.

Duct Losses

The following "DUCT" keywords apply to air and heat loss through supply ducting. Return ducts are assumed to have no losses.

DUCT-ZONE

U-name of the zone that contains the ducts for the system. This zone receives the heat gains or losses from the ducts. Only one zone may be specified for each system. If not specified, this keyword defaults to the first plenum zone entered or, if no plenum zone exists, to the first ZONE entered after the SYSTEM command. The zone may be either unconditioned (such as an attic) or a plenum; if the RETURN-UA is specified, then plenums cannot exist, and the ducts must be located in an unconditioned zone. The location of piping is specified in the CIRCULATION-LOOP command.

DUCT-AIR-LOSS

Fraction of the supply air that is lost from the ductwork, thereby reducing the design supply air at the zones. Air lost from the ductwork will change the temperature of the zone specified by DUCT-ZONE, which must be a plenum or unconditioned space.

If the DUCT-ZONE is a plenum, then the duct air loss changes the temperature of the return air entering the plenum. If the DUCT-ZONE is an unconditioned space the duct air loss acts to change the temperature of the zone. The program does not currently simulate duct losses to conditioned spaces.

DUCT-AIR-LOSS-OA

when the DUCT-AIR-LOSS is non-zero, and the DUCT-ZONE is an unconditioned zone, specifies the fraction of the supply duct air loss that is made up by outside air. The remainder of the supply duct air loss is assumed to infiltrate into the return duct from the DUCT-ZONE. The default is 1.0, meaning that all of the duct loss is made up by outside air, and none from the zone containing the ductwork.

When the DUCT-ZONE is an unconditioned zone such as an attic, the temperature of the attic may be considerably hotter than the outside air. This keyword allows you to specify how much of the duct air loss is made up from outside air (assumed to directly enter the unit), vs. attic air (assumed to enter the return ducting).

The default of 1.0 (100% OA makeup) assumes that the return ducting is not in that attic, or that the ducting is not leaky. In this case, the supply air lost to the attic will act to cool the attic, and will then exfiltrate to the outdoors. The space conditioning system will draw an equal amount of air from the outdoors to make up the loss. If this keyword is 0.0, then the supply air lost to the attic will still act to cool the attic, but instead of exfiltrating to the outdoors, will infiltrate into the return ductwork at the attic temperature.

This keyword has no effect when the DUCT-ZONE is a plenum. In this case, all of the duct air loss enters the plenum and returns to the unit.

DUCT-DT

The average duct temperature rise when delivering cooled air at the design cooling conditions of MIN-SUPPLY-T for the air and DESIGN-COOL-T for the zone, given by DUCT-ZONE, in which the duct is located. Applies to all single-duct systems and to the cold duct of a dual-duct system. The value represents the average temperature rise of all air delivered. In actual systems, zones further from the air handler (on longer duct runs) will normally experience larger losses than zones closer to the air handler. Therefore, larger air flows will be required to make up the difference. This effect is not explicitly modeled.

The default of 0.0 implies no duct losses. A typical value may be 2-4F (1-2K) for a building with an area of 20,000 ft² (1860 m²) per floor where the ducts are located in a return air plenum.

The program uses DUCT-DT to calculate a duct UA product at the design conditions (see also DUCT-UA). This UA includes losses through the duct walls, hangers, etc. Based on the inferred UA, the program will calculate the losses on an hourly basis as a function of supply air temperature, DUCT-ZONE temperature, and the actual air flow through the duct. The load and temperature of the DUCT-ZONE will be affected. In single-duct systems, the inferred UA is also used to calculate heat losses from the duct when in the heating mode.

DUCT-UA

The UA value of the duct. See DUCT-DT. Overrides the value entered for DUCT-DT. The UA value should include losses through the duct insulation as well as any bypass effects due to the duct hangars, crushed insulation, etc.

HOT-DUCT-DT

Takes a negative value equal to the average duct temperature drop when delivering heated air at the design heating conditions of MAX-SUPPLY-T for the air and DESIGN-HEAT-T for DUCT-ZONE, the zone in which the ducting is located. Applies only to the hot duct of a dual-duct system. Losses for the cold duct of a dual-duct system and all single-duct systems are specified using DUCT-DT. For a dual-duct system, if this value is not specified but the DUCT-DT is specified, then the program will infer a value for the hot duct as well.

HOT-DUCT-UA

The UA value of the hot duct of a dual-duct system. Overrides the value entered for HOT-DUCT-DT. This value should include losses through the duct insulation as well as any bypass effects due to the duct hangars, crushed insulation, etc.

RETURN-UA

The UA value of the return duct. This value should include losses through the duct insulation as well as any bypass effects due to the duct hangars, crushed insulation, etc. This keyword applies only for air handlers having return ducts; if the return is via plenums, then this keyword is ignored.

Ventilation Air

The following keywords define the parameters for ventilation air, including economizer and evaporative cooling.

MIN-OUTSIDE-AIR

The minimum outside air flow divided by the supply air flow during winter heating periods. You may alternatively, or additionally, specify outside air quantities at the zone level using the ZONE keywords OA-CHANGES, OA-FLOW/PER or OUTSIDE-AIR-FLOW. The default is calculated from zone loads and ZONE input.

If you enter MIN-OUTSIDE-AIR as well as the ZONE keywords OUTSIDE-AIR-FLOW, OA-CHANGES, OA-FLOW/PER or EXHAUST-FLOW, the ZONE values take precedence. If no zone-level values are specified, MIN-OUTSIDE-AIR will be used. If MIN-AIR-SCH is specified, MIN-OUTSIDE-AIR, or the corresponding ZONE values, should be entered.

The program will not allow MIN-OUTSIDE-AIR to be less than the sum of the EXHAUST-FLOWS for all zones divided by the sum of all supply flows for all zones. That is, the exhaust fan operation will override MIN-OUTSIDE-AIR if MIN-OUTSIDE-AIR is set too low.

The minimum outside air ratio reported on SV-A is based on the design calculated supply air flow and not on the value input for SUPPLY-FLOW, which overrides the design flow rate.

When evaporative cooling is in effect, the outside air dampers are 100% open. When outside air is able to cool the building without the aid of evaporative cooling, the outside and return air dampers modulate open.

OA-SIZING-METHOD

Allows the choice of method used to calculate the **design and hourly minimum** outside air flow rate fraction for multi-zone air system types; this keyword does not apply to SUM/FPH, zonal systems UVT/FC/HP/PTAC, or not OA systems UHT/RESYS/RESVVT.) One method allowed is the summation of ZONE OA flow requirements into a SYSTEM OA flow requirement; this is then divided by the calculated/specified SUPPLY-FLOW to set the MIN-OUTSIDE-AIR keyword which is also used in the design/sizing calculation. Another option is available to calculate the SYSTEM OA requirement based upon the ZONE requiring the highest fraction of OA flow relative to its design supply flow; this is the method required by ASHRAE Standard 62. If the MIN-AIR-SCH is specified, its hourly specified value will always be used (even if OA-SIZING-METHOD is specified) unless the hourly scheduled value is -999. The allowed codewords are:

SUM-OF-ZONE-OA (default) The program calculates the SYSTEM design OA flow fraction based upon a sum of the zone requirements divided by the SUPPLY-CFM. This is the default and the method used in previous releases of DOE-2. In each zone OA calculation, a specified MIN-OUTSIDE-AIR overrides any specified values for OA-CHANGES (times zone VOLUME/60), OA-FLOW/AREA (times the zone AREA.) and OA-CFM/PER (times the NUMBER-OF-PEOPLE).

SET-BY-CRITICAL-ZONE The program calculates the SYSTEM design OA flow fraction based upon the ZONE with the highest OA requirement. In each ZONE OA calculation, a specified MIN-OUTSIDE-AIR overrides any specified values for OA-CHANGES (times SPACE VOLUME/60), OA-FLOW/AREA (times the zone AREA.) and OA-CFM/PER (times the NUMBER-OF-PEOPLE) The value for zone OA ventilation flow rate is then divided by the specified/calculated zone

supply flow rate and the zone with the highest such value (the “critical” zone) is found. Setting the sum of the zone OA requirements divided by the system total supply fan flow rate to X , and the critical zone OA fraction to Z , then the system design and hourly minimum OA flow fraction is set to $X/(1+X-Z)$. This is the method specified for multi-zone systems in ASHRAE Standard 62.

MIN-OA-METHOD

Specifies whether the design minimum outside air fraction is constant, or varies with airflow and allows the choice of method used to set the hourly minimum OA damper position. This keyword only has an effect on the minimum damper position with any specified outside air economizer operation working as specified (or defaulted) via the economizer related keywords. For system without an economizer, or with the economizer feature not specified, this keyword is operational but specifies how the outside air damper position is controlled each hour. This also allows the modeling of two types of demand controlled ventilation (DCV) sensor placements: sensing the average zone requirement (such as placement of a sensor in the return air) and sensing the highest zone requirement (such as placing sensors in each zone or the critical zone.) If the MIN-AIR-SCH is specified, its hourly specified value will always be used (even if MIN-OA-METHOD is specified) unless the hourly scheduled value is -999. MIN-OA-METHOD is now used by zonal systems to add DCV to each zone unit. When INDOOR-FAN-MODE = INTERMITTANT in FC systems, during the hours when DCV is active (MIN-OA-METHOD = DCV codeword and MIN-AIR-SCH, if specified, has an hourly value of -999.) the INDOOR-FAN-MODE is switched to CONTINUOUS for that hour.

FRACTION-OF-DESIGN the default, indicates that the method used to interpret the value of the minimum outside air specification is to use it as a required fraction of the design flow; the design minimum OA fraction used can be set by OA-SIZING-METHOD. Thus, in systems having variable air volume capabilities the hourly ratio of minimum outside air to actual hourly flow will increase as the flow decreases.

FRACTION-OF-HOURLY indicates that the method used to interpret the value of the minimum outside air specification is to use it as a constant fraction of each hours flow; the minimum OA fraction used can be set by OA-SIZING-METHOD. Thus, in systems having variable air volume capabilities the hourly ratio of minimum outside air to actual hourly flow will be constant, and the amount of outside air will vary as the supply flow varies.

DCV-RETURN-SENSOR This codeword instructs the program to model a DCV device that uses a CO₂ differential between the SYSTEM return air stream and OA intake air stream to determine the hourly minimum OA fraction. The program calculates the OA minimum requirement and sets the minimum damper position hourly based upon the sum of the ZONE requirements. Each zone OA requirement is calculated based upon the hourly maximum of either OA-CFM/PER (times the NUMBER-OF-PEOPLE adjusted by the hourly PEOPLE-SCHEDULE) or a minimum OA ventilation rate. The zone minimum OA ventilation rate is either MIN-OUTSIDE-AIR if specified or the maximum of OA-CHANGES (times the zone VOLUME/60), OA-FLOW/AREA (times the zone AREA.)

DCV-ZONE-SENSORS This codeword instructs the program to model a DCV device that uses the highest CO₂ differential between the each ZONE air and OA intake air stream to determine the hourly minimum OA fraction. The program calculates the OA minimum requirement and sets the minimum damper position hourly using the “critical” zone requirement; the critical zone requirement is defined as the zone having the highest fraction of OA relative to its hourly supply air flow rate. Each zone OA requirement is calculated based upon the hourly maximum of either

OA-CFM/PER (times the NUMBER-OF-PEOPLE adjusted by the hourly PEOPLE-SCHEDULE) or a minimum OA ventilation rate. The zone minimum OA ventilation rate is either MIN-OUTSIDE-AIR if specified or the maximum of OA-CHANGES (times the zone VOLUME/60), OA-FLOW/AREA (times the zone AREA.). The value of the zone minimum OA ventilation flow rate is divided by the specified/calculated zone supply flow to calculate hourly zone OA fraction; the zone with the highest hourly flow fraction value is the “critical” zone. Setting the sum of the ZONE OA flow requirements divided by the system total supply fan flow to X, and letting the critical zone OA fraction be denoted as Z, the system hourly minimum OA flow fraction is then $X/(1+X-Z)$

MIN-AIR-SCH

Takes the U-name of a SCHEDULE that contains hourly values of the ratio of minimum outside air flow to supply air flow. Values in the MIN-AIR-SCH vary from 0.0 (no outside air flow; economizer inactive if specified) to 1.0 (100% outside air flow). A value of 0.001 activates the economizer. A value of -999 returns the hourly value to MIN-OUTSIDE-AIR or to the program's calculated minimum outside air value (found on report SV-A for the SYSTEM or for each zone for zonal systems). During a warmup period, this schedule is normally set to zero and can then be set to -999 during other hours to allow the specified or calculated ventilation minimum damper position to be used. Note that schedules are ignored in the design routines; therefore, the minimum ventilation air desired for design must be specified either at the zone or system level.

MAX-OA-FRACTION

Upper limit on the outside air flow allowed when a temperature- or enthalpy-controlled economizer is operating, expressed as a fraction of the supply air flow. This keyword should be used only if the outside dampers do not allow 100% outside air.

OA-FROM-SYSTEM

Takes the U-name of the system that supplies dehumidified make-up air either directly, or through the corridor, to apartments or hotel rooms. Make sure that minimum outside air of a make-up air system assigned to the corridor matches the sum of the minimum outside air flow rate of the apartments or hotel rooms. In the input, define the make-up air system prior to the apartment or hotel room system. Several Error and Warning messages are present to prevent incorrect simulations and only simple sizing calculations are available for OA-FROM-SYSTEM referenced SYSTEMs. In previous versions of DOE-2.2 (before 44c) and 2.1E, if a SYSTEM had an OA-FROM-SYSTEM specified, the referencing SYSTEM value for MIN-OUTSIDE-AIR was reset to the MIN-OUTSIDE-AIR of the referenced OA-FROM-SYSTEM; this has been removed and replaced with the action as described next. The sum of the OA requirements for all SYSTEMs that reference an OA-FROM-SYSTEM is used to set the referenced OA-FROM-SYSTEM value for MIN-OUTSIDE-AIR, SUPPLY-FLOW as well as adjust the referenced OA-FROM-SYSTEM directly served ZONE maximum and minimum flows for both heating and cooling. Additionally the referenced OA-FROM-SYSTEM has its calculated/specified cooling (total and sensible), heating, and preheat capacities adjusted if its SUPPLY-FLOW was increased. If the referenced OA-FROM-SYSTEM and its ZONEs have sufficient minimum OA specified (greater than that required by the referencing SYSTEMs) no adjustments are made. If any adjustments are made a warning is issued that informs the user of the adjustments and recommends the project be re-run with the values in the input corrected. Also, errors are issued (and the simulation terminated) if the referenced OA-FROM-SYSTEM is either an incorrect type (a zonal system or a system that cannot have outside air) or the referenced OA-FROM-SYSTEM is not placed into the input file before all referencing SYSTEMs.

Outside Air Economizer Cycles

For all economizer types, the economizer controls vary the proportion of outside air to return air to maintain the mixed air temperature setpoint. In no case, however, will the outside air fraction be less than the minimum allowed,

nor greater than the maximum allowed. Note that the minimum outside air quantity may vary hourly as defined by the MIN-AIR-SCH.

Some of the keywords define economizer control sequences that, while not common, are achievable using direct-digital controls, and may be desirable for some buildings.

OA-CONTROL

accepts a code-word specifying the type of economizer control. The default varies by system type.

FIXED	specifies that a fixed amount of outside air is used whenever the fans are running.
OA-TEMP	specifies that the economizer is enabled whenever the outside air temperature is below the maximum allowed temperature, as specified by DRYBULB-LIMIT.
OA-ENTHALPY	specifies that the economizer is enabled whenever the outside air enthalpy is below the maximum allowed enthalpy, as specified by ENTHALPY-LIMIT.
DUAL-TEMP	specifies that the economizer is enabled whenever the outside air temperature is less than the return air temperature.
DUAL-ENTHALPY	specifies that the economizer is enabled whenever the outside air enthalpy is less than the return air enthalpy.

DRYBULB-LIMIT

Specifies the maximum allowable outside air temperature for which the economizer is enabled. The outside air dampers return to their minimum position above this value. The default is 65°F.

For OA-CONTROL = TEMP, this keyword is always used. For all other economizer types, this keyword is an optional limit, and acts only when specified.

ENTHALPY-LIMIT

Specifies the maximum allowable outside air enthalpy for which the economizer is enabled. The outside air dampers return to their minimum position above this value. The default is 30.0 Btu/lb.

For OA-CONTROL = ENTHALPY, this keyword is always used. For all other economizer types, this keyword is an optional limit, and acts only when specified.

DUAL-TEMP-DT

for OA-CONTROL = DUAL-TEMP, specifies an optional differential between the return air and the outside air temperatures. The default is 0°F, which means that the economizer will operate whenever the outside-air temperature is less than the return-air temperature.

A positive value means that the outside air must be colder than the return by that value. For example, if the DUAL-TEMP-DT is 5°F and the return air temperature is 75°F, then the outside air must be below 70°F for the economizer to be enabled. A positive value may provide additional energy savings in humid climates.

Negative values are also acceptable. For example, if the DUAL-TEMP-DT is -5°F and the return air is 75°F, then the economizer is enabled whenever the outside air is below 80°F. A negative value may provide additional savings in dry climates, especially in buildings having high internal latent heat gains.

DUAL-ENTHALPY-DH

for OA-CONTROL= DUAL-ENTHALPY, specifies an optional differential between the return air and the outside air enthalpies. The default is 0 Btu/lb, which means that the economizer will operate whenever the outside-air enthalpy is less than the return-air enthalpy.

A positive value means that the outside air must have a lower enthalpy than the return by that value. For example, if the DUAL-TEMP-DH 3 Btu/lb and the return air enthalpy is 30 Btu/lb, then the outside air must be below 27 Btu/lb for the economizer to be enabled. A positive value may help to prevent excessive space humidity when economizer operation would otherwise be sufficient to satisfy the cooling load. For example, a store located in a humid climate and having a well-designed daylighting system may have internal loads so low some hours that excessive space humidity could be a problem.

Negative values are also acceptable. For example, if the DUAL-TEMP-DH is -3 Btu/lb and the return air enthalpy 30 Btu/lb, then the economizer is enabled whenever the outside air is below 33 Btu/lb. A negative value may help to prevent excessive space humidity in buildings operating in cold climates and having large internal latent gains.

ECONO-LOW-LIMIT

for all economizer types, specifies a minimum temperature below which the outside air dampers return to their minimum position. If not specified, there is no minimum allowable temperature.

This feature may be useful when the building has a heat-recovery chiller, and it is desirable to run the chiller at low outside-air temperatures to provide space heating. It may also be useful for buildings having humidifiers, where the use of extremely cold, dry outside air to provide space cooling may actually introduce an energy penalty (but see ECONO-MIN-W for a better way to integrate an economizer with a humidifier).

ECONO-MAX-W

for all economizer types, specifies a maximum outdoor-air humidity ratio above which the outside air dampers return to their minimum position. If not specified, there is no maximum allowable humidity ratio.

This feature can prevent excessively high humidity levels in buildings that have relatively small internal heat gains some hours, and are located in humid climates. For example, a store having a well-designed daylighting system may have cooling loads so low during mild, humid weather that mechanical cooling is not required. But, if economizer cooling is used in these circumstances, excessive space humidity could be a problem.

ECONO-MIN-W

for all economizer types, specifies a minimum mixed-air humidity ratio below which the outside air dampers return to their minimum position. If not specified, there is no minimum allowable temperature. If specified, this control will override the mixed-air temperature controller to prevent the mixed-air humidity ratio from dropping below this value.

This feature can prevent excessively low humidity levels in buildings located in very cold or dry climates, and may be especially useful when humidifiers are used. Oftentimes, the energy saved by using an economizer may be more than offset by the energy consumed in re-humidifying very dry air.

ECONO-LOCKOUT

for a packaged-DX system, accepts a code-word specifying whether the economizer is locked out when the compressor is operating.

YES

specifies that the economizer and the compressor cannot operate simultaneously. If the economizer cannot handle the entire cooling load, then mechanical cooling will be enabled and the economizer will return to its minimum position. This

control sequence is equivalent to what the California Energy Commission calls a non-integrated economizer.

NO specifies that the economizer can operate simultaneously with the compressor. The economizer will operate to provide as much of the cooling load as possible, with mechanical cooling picking up the remainder of the load. This type of operation is more efficient than a non-integrated economizer, but requires safeguards to ensure proper compressor operation. This control sequence is equivalent to what the California Energy Commission calls an integrated economizer.

ECONO-SCHEDULE

accepts the U-name of a schedule of type ON/OFF that enables, but does not control economizer operation. Normally, the economizer may operate whenever the fan is running, depending on the type of OA-CONTROL. A value of 0 in the ECONO-SCH forces the economizer to its minimum position, regardless of other controls. A value of 1 allows the economizer to operate according to the specified OA-CONTROL sequence.

Energy-Recovery Ventilators (ERVs)

This section describes the capabilities of the SYSTEM component to simulate Air-to-Air Energy Recovery Ventilators (ERVs). These devices recover heating and/or cooling energy from a building's exhaust airflow, and return it to the make-up (outdoor) airflow. They utilize a variety of heat-recovery technologies, including crossflow heat-exchangers, heat wheels (sensible or total), and heat pipes. Depending on the technology, an ERV may recover both sensible and/or latent heat.

ERVs may be controlled in a variety of ways, including continuous operation, scheduled operation, temperature differential between outdoor and return air, enthalpy differential between outdoor and return air, heating mode only, cooling mode only, etc. The method by which the ERV is controlled is critical to its energy-saving potential; a poorly controlled ERV may in some cases use more energy than it saves. This is because an ERV may recover heat when it is not wanted; there is also an increase in fan energy due to the static pressure drop of the ERV.

RECOVER-EXHAUST

accepts a code-word specifying whether an ERV exists:

NO the default, indicates that no exhaust-air heat recovery will take place.

YES specifies that an energy-recovery ventilator (ERV) exists, as defined by the following keywords.

ERV-RECOVER-TYPE

accepts a code-word defining the type of energy-recovery ventilator:

SENSIBLE-HX specifies an ERV utilizing a conventional heat-exchanger that recovers sensible heat only. The heat-exchanger is typically in a crossflow configuration.

ENTHALPY-HX specifies an ERV utilizing a conventional heat-exchanger that recovers both sensible and latent heat (total energy). Note that a manufacturer's survey at the time of this implementation did find any ERVs of this type. Therefore, the potential performance of this type of ERV is unknown (if it even exists). Accordingly, many of the following keywords do not have defaults for this type, and require mandatory entries instead.

SENSIBLE-WHEEL	specifies an ERV utilizing a finned heat wheel that recovers sensible heat only. The make-up and exhaust air streams flow through opposite sides of the wheel in a counterflow configuration. Fins in the warmer air stream pick up heat, and as the wheel rotates, transfer the heat into the cooler air stream
ENTHALPY-WHEEL	specifies an ERV utilizing a finned heat wheel that recovers both sensible and latent heat (total energy). This type is similar to the SENSIBLE-WHEEL, with the addition of a desiccant coating on the wheel's fins. The desiccant, typically a molecular sieve or silica gel, adsorbs moisture from the more humid air stream and transfers the moisture to the drier air stream.
HEAT-PIPE	specifies an ERV utilizing a heat pipe. The air streams are typically arranged in a counterflow configuration.

ERV-OA-FLOW

specifies the design outdoor airflow at which the ERV is rated. The default is the design outside airflow rate of the HVAC system. Normally, the design airflow is the same on both the make-up and exhaust sides of the heat-exchanger, but the values may be different.

If you have also specified an ERV-PURGE, the ERV-OA-FLOW specifies the airflow *leaving* the ERV; the flow *entering* the ERV will be increased by the ERV-PURGE.

Note also that, while the *design* airflow on both sides of the heat-exchanger is usually the same, the *actual* hourly airflows may be different from design, and may be different from each other. The exhaust airflow will be less than the make-up airflow whenever air exfiltration exists. Air exfiltration exists when either of the following conditions occur:

The RETURN-CAP-RATIO is specified, and the resulting differential between supply and return airflow is greater than the sum of the zonal exhausts.

A DUCT-AIR-LOSS is specified, and the ducting is located in an unconditioned zone. The air lost from the duct is presumed to exfiltrate. Note that if the duct is located in a plenum, then the duct leakage joins the plenum return airflow, and does not exfiltrate.

All exhaust other than exfiltration is assumed to flow through the ERV. This includes both zonal and central exhaust.

ERV-EXH-FLOW

specifies the design outdoor airflow at which the ERV is rated. The default is the ERV-OA-FLOW. Normally, the design airflow is the same on both the make-up and exhaust sides of the heat exchanger, but the values may be different.

If you have also specified an ERV-PURGE, the ERV-EXH-FLOW specifies the airflow entering the ERV; the flow leaving the ERV will be increased by an amount equal to the ERV-OA-FLOW * ERV-PURGE.

Note also that, while the *design* airflow on both sides of the heat-exchanger is usually the same, the *actual* hourly airflows may be different from design, and may be different from each other. The exhaust airflow will be less than the make-up airflow whenever air exfiltration exists. Air exfiltration exists when either of the following conditions occur:

The RETURN-CAP-RATIO is specified, and the resulting differential between supply and return airflow is greater than the sum of the zonal exhausts.

A DUCT-AIR-LOSS is specified, and the ducting is located in an unconditioned zone. The air lost from the duct is presumed to exfiltrate. Note that if the duct is located in a plenum, then the duct leakage joins the plenum return airflow, and does not exfiltrate.

All exhaust other than exfiltration is assumed to flow through the ERV. This includes both zonal and central exhaust.

ERV-PURGE

for SENSIBLE-WHEELs and ENTHALPY-WHEELs only, specifies the fractional increase in the design outdoor airflow that purges the heat wheel. The default is 0.

As a heat-wheel rotates from the exhaust airstream into the supply airstream, a small amount of the exhaust air is traversing the flutes of the wheel media as it passes by the seal separating the two airstreams. If this volume of exhaust air were allowed to mix with the clean supply airstream, cross-contamination of the supply will occur. This cross-contamination can be minimized by incorporating a purge section that utilizes the pressure difference which exists between the outdoor and return airstreams to purge the transfer media with clean outdoor air prior to its rotation into the supply airstream.

While a purge may be desirable for some industrial or laboratory heat-recovery processes (fume hood exhausts, etc.), it is not normally necessary in commercial office applications.

Typical purge volumes are in the range of 10-20% of the design outdoor air volume leaving the ERV. The purge volume is in addition to the amounts specified for supply and exhaust. For example, if ERV-OA-FLOW = 10000, ERV-EXH-FLOW = 8000, and ERV-PURGE = 0.10, then

$$\begin{aligned} \text{Purge volume} &= 10,000 * 0.1 = 1,000 \text{ cfm} \\ \text{OA entering ERV} &= 10,000 + 1,000 = 11,000 \text{ cfm} \\ \text{Exh leaving ERV} &= 8,000 + 1,000 = 9,000 \text{ cfm} \end{aligned}$$

The purge volume is based on the design outdoor air volume, and is constant all hours. In other words, while the actual outdoor air volume may vary hourly, the purge volume does not.

Finally, a purge requires that the static pressure in the outdoor air stream be higher than in the exhaust stream. This pressurization requires the use of fans integral to the ERV (ERV-FANS = SELF-CONTAINED)

The next set of keywords defines the sensible and latent heat transfer performance of the ERV. The program uses an NTU/effectiveness algorithm to model the sensible heat transfer. The heat-exchanger effectiveness varies hourly as a function of the make-up and exhaust airflows. To accomplish this, the program uses the design airflow, design heat-exchanger effectiveness, and heat-exchanger configuration to determine the effective UA product of the heat-exchanger. The design UA product in turn is broken down into a media resistance and air film coefficients. The film coefficients vary hourly as a function of make-up and exhaust airflows, with the hourly UA and effectiveness varying accordingly.

Latent heat transfer is simulated in an identical manner to sensible heat transfer. Here, the program uses an analogy to the NTU/effectiveness model, where the "UA" is actually the moisture transport capacity of the heat-exchange process.

ERV-HX-CONFIG

accepts a code-word specifying the heat-exchanger configuration. The program supports a variety of heat-exchanger configurations, but ERVs typically only use two types:

CROSSFLOW the default for the SENSIBLE-HX, specifies a crossflow heat-exchanger with unmixed airstreams.

COUNTERFLOW the default for heat wheels and heat pipes, specifies a heat-exchanger having airstream arranged in a counterflow configuration.

Other standard heat-exchanger configurations are also available, but are not commonly used in ERVs: PARALLELFLOW, CROSSFLOW-MIXED, CROSSFLOW-SUP-MIXED, CROSSFLOW-DEM-MIXED, and PARALLEL-COUNTERFLOW-1-2.

ERV-SENSIBLE-EFF

specifies the sensible effectiveness at the design airflow. The program calculates the design UA product of the heat-exchanger as a function of this effectiveness and the design airflow. For the purposes of this calculation only, the program assumes that the design airflow is the same through both sides of the heat-exchanger, and is equal to the ERV-OA-FLOW. In other words, the ERV-EXH-FLOW and ERV-PURGE are ignored in this calculation.

Note that this effectiveness is only the design effectiveness; the program calculates the hourly effectiveness as a function of the design UA product and the actual hourly outdoor and exhaust airflows. The hourly airflows may vary, and the outdoor flow may be different from the exhaust flow as described elsewhere in this section.

ERV-SEN-FILM-RES

specifies the fraction of the design heat-exchanger resistance ($1/UA$) that is due to the air films. This fraction is inclusive of the air films on both sides of the heat-exchanger. Both film resistances are assumed to be equal, so the fraction of the total resistance due to a single air film is one-half this value. The remainder of the resistance is due to conduction through the heat-exchanger material.

ERV-SEN-FILM-EXP

specifies the exponent used to vary an air film resistance as a function of the hourly airflow. This exponent applies to both sides of the heat-exchanger. A value of 0.0 implies totally laminar airflow, meaning that the film resistance does not change with airflow. Larger values imply increasingly turbulent airflows.

ERV-LATENT-EFF

specifies the latent effectiveness at the design airflow. The program calculates the design latent "UA" product of the heat-exchanger as a function of the effectiveness and airflow.

ERV-LAT-FILM-RES

specifies the fraction of the design latent heat-exchanger resistance ($1/UA$) that is due to the air films. This fraction is inclusive of the air films on both sides of the heat-exchanger. Both film resistances are assumed to be equal, so the fraction of the total resistance due to a single air film is one-half this value. The remainder of the resistance is due to conduction through the heat-exchanger material.

ERV-LAT-FILM-EXP

specifies the exponent used to vary an latent air film resistance as a function of the hourly airflow. This exponent applies to both sides of the heat-exchanger. A value of 0.0 implies totally laminar airflow, meaning that the film resistance does not change with airflow. Larger values imply increasingly turbulent airflows.

The next set of keywords define the ERV's control sequences. An ERV may act in a totally passive mode whereby the heating or cooling it provides to the outdoor air is strictly a function of the temperature difference and flows of the two airflows. Alternatively, it may be controlled to operate only under certain conditions, and/or to modulate itself so that the make-up air is at a desired temperature setpoint.

The energy savings potential can vary markedly depending on the control sequence. An ERV that operates continuously with the HVAC fans can incur a significant fan energy penalty. In addition, it may recover heat when the heat is not needed, thereby increasing cooling energy. A properly controlled ERV may prove to be cost effective, while the same ERV improperly controlled may actually increase energy usage and cost.

To properly understand these control sequences, it is important to distinguish the difference between "heating mode" and "cooling mode" as they apply to an air handler vs. its ERV:

An air handler is in the heating mode whenever it is raising the *mixed-air* temperature using a central heating coil. Conversely, an air handler is in the cooling mode whenever it is lowering the mixed air temperature using a cooling coil and/or economizer.

An ERV is in the heating mode whenever it is raising the *outdoor-air* temperature. Conversely, it is in the cooling mode when it is cooling the outdoor air.

An air handler and its ERV may be operating in either the same or opposite modes. For example, consider an air handler having 75°F return air and operating in the winter with a 55°F setpoint. The outdoor air is 40°F. In this case, the air handler is in the *cooling mode* because the supply air setpoint is lower than the return air temperature, and the unit is using its cooling coil and/or economizer to reduce the temperature. However, if the ERV is operating, it will be operating in the *heating mode*, as it is transferring heat from the warm exhaust air to the cold outdoor air, thereby raising its temperature. (Note that individual zones may be reheating the supply air, but here we are focusing only on the operation of the central system.)

The temperature of the make-up air leaving the ERV (entering the mixed air plenum) may either float according to the outdoor and exhaust air temperatures, or be actively controlled. When floating, the ERV may overcompensate for the outdoor air temperature, thereby reducing or even reversing the potential energy savings of the ERV.

For example, consider an air handler with a supply setpoint of 55°F, a return temperature of 75°F, and an outdoor air temperature of 30°F. Assume also that at the current supply airflow, the fraction of outdoor air is 70% of the supply:

If the ERV is off, the mixed air temperature will be $30^{\circ}\text{F} \cdot 0.7 + 75^{\circ}\text{F} \cdot 0.3 = 43.5^{\circ}\text{F}$, which is lower than the 55°F supply-air setpoint. The central heating coil will have to operate to raise the mixed air temperature to setpoint.

If the ERV is operating and has an effectiveness of 80%, then the temperature of outdoor air leaving the ERV and entering the mixed air plenum will be $30^{\circ}\text{F} + (75-30) \cdot 0.8 = 66^{\circ}\text{F}$. The mixed air temperature will be $66^{\circ}\text{F} \cdot 0.7 + 75^{\circ}\text{F} \cdot 0.3 = 68.7^{\circ}\text{F}$, which is considerably warmer than the supply-air setpoint. The cooling coil will have to operate to lower the mixed-air temperature to setpoint.

As can be seen, neither of the above scenarios is satisfactory. There are several possible solutions to this problem:

Economizer trim - If the HVAC system has an integral economizer, the economizer dampers can be cracked open to increase the total outdoor airflow. The ERV still processes the same amount of air, but additional outdoor air is admitted into the mixed-air plenum via the economizer. In the above

example, if the economizer is fully open, then the mixed air temperature will be $66^{\circ}\text{F} \times 0.7 + 75^{\circ}\text{F} \times 0.0 + 30^{\circ}\text{F} \times 0.3 = 55.2^{\circ}\text{F}$.

Outside air bypass - The ERV can incorporate an integral bypass damper that reduces the amount of outside air that passes through the heat-exchanger. The total outdoor airflow remains constant; some simply bypasses the ERV. This control mechanism allows the ERV to modulate its outlet temperature to exactly what is needed. In the above example, the required outlet temperature (including the amount bypassed) will be: $T_{\text{erv}} = (T_{\text{mix}} - (1 - \text{OAfrac}) \times T_{\text{exhaust}}) / \text{OAfrac} = (55^{\circ}\text{F} - (1 - 0.7) \times 75^{\circ}\text{F}) / 0.7 = 46.4^{\circ}\text{F}$

HX modulation - The ERV can modulate the capacity of its heat-exchanger. A heat wheel can accomplish this through the use of a variable-speed wheel. The required outlet temperature is the same as for the ERV with bypass.

For an enthalpy heat-exchanger, each of the above control strategies will have a different impact on the resulting mixed-air humidity ratio. This can be important if the HVAC system also has a humidifier.

ERV-RUN-CTRL

accepts a code-word defining when the ERV will operate. This keyword operates in conjunction with ERV-RECOVER-MODE. Acceptable entries are:

WHEN-FANS-ON	the default, specifies that the ERV operates all hours that the HVAC fans are running. This mode can allow undesirable heat recovery and excessive fan energy consumption. For example, if the system is currently using economizer cooling and the ERV is running, it will recover heat from the warm exhaust air stream and put it back into the cooler outside air stream, thereby diminishing the effectiveness of the economizer cycle. To prevent this, specify WHEN-MIN-OA
WHEN-MIN-OA	specifies that the ERV operates only when the outside air dampers are at their minimum position (i.e., the economizer is inactive). If the building has no economizer, then WHEN-MIN-OA is equivalent to WHEN-FANS-ON.
ERV-SCHEDULE	specifies that the ERV has its own operating schedule. Note that this schedule can lock out the ERV when it would otherwise be running, but cannot force the ERV to run when the HVAC fans are off.
OA-EXHAUST-DT	specifies that the ERV will operate when the HVAC fans are on, and the temperature differential between the outside air and the exhaust is at least this value. The ERV-RECOVER-MODE may additionally limit operation to either the ERV heating mode (only when heating the outdoor air) or the cooling mode (cooling the outdoor air).
OA-EXHAUST-DH	specifies that the ERV will operate when the HVAC fans are on, and the enthalpy differential between the outside air and the exhaust is at least this value. The ERV-RECOVER-MODE may additionally limit operation to either the ERV heating mode (only when heating the outdoor air) or the cooling mode (cooling the outdoor air).

ERV-SCHEDULE

when ERV-RUN-CTRL = ERV-SCHEDULE, accepts the U-name of the schedule that defines when the ERV operates. Note that the ERV will never operate when the HVAC fans are off.

OA-EXHAUST-DT

when ERV-RUN-CTRL = OA-EXHAUST-DT, specifies the temperature differential between the outside air and exhaust air streams. The ERV will operate whenever the absolute value of the differential is at least this value, and the HVAC fans are operating. The default is 5°F.

OA-EXHAUST-DH

when ERV-RUN-CTRL = OA-EXHAUST-DH, specifies the enthalpy differential between the outside air and exhaust air streams. The ERV will operate whenever the absolute value of the differential is at least this value, and the HVAC fans are operating. The default is 1 Btu/lb-°F.

ERV-RECOVER-MODE

when ERV-RUN-CTRL = OA-EXHAUST-DT or OA-EXHAUST-DH, accepts a code-word specifying when the ERV will operate:

OA-HEATING	the default for sensible-only ERVs, indicates that the ERV will operate only when it can heat the outdoor air, and only when the differential between the outdoor air and the exhaust exceeds the specified differential.
OA-COOLING	indicates that the ERV will operate only when it can cool the outdoor air, and only when the differential between the outdoor air and the exhaust exceeds the specified differential.
OA-HEAT/COOL	the default for enthalpy ERVs, indicates that the ERV will operate whenever the absolute value of the differential between the outdoor air and the exhaust exceeds the specified differential.

ERV-TEMP-CTRL

accepts a code-word describing the mechanism used to control the make-up air temperature leaving the ERV:

FLOAT	the default, specifies that the ERV has no active outlet temperature control; the outlet air temperature floats with the outdoor/exhaust airflows and air temperatures. This may result in an overheating or overcooling of the mixed-air temperature as described in the general discussion.
FIXED-SETPT	specifies that the ERV outlet temperature will be controlled to a fixed setpoint, depending on whether the air handler is in the heating or cooling mode. This strategy may reduce the overheating or overcooling problem.
MIXED-AIR-RESET	specifies that the ERV outlet temperature will be controlled to the temperature necessary for the mixed-air temperature to be at setpoint. This strategy can eliminate the potential overheating or overcooling problem. Note that the mixed-air temperature is not the temperature leaving the ERV; it is the combination of the air leaving the ERV and the return air.

OA-HEAT-SETPT-T

when ERV-TEMP-CTRL = FIXED, specifies the outlet make-up air temperature setpoint when the air handler is in the heating mode (return temperature less than required mixed-air temperature). This is a mandatory entry for this mode.

OA-COOL-SETPT-T

when ERV-TEMP-CTRL = FIXED, specifies the outlet make-up air temperature setpoint when the air handler is in the cooling mode (return temperature greater than required mixed-air temperature). This is a mandatory entry for this mode.

ERV-CAP-CTRL

accepts a code-word specifying the ERV capacity control mechanism.

This control mechanism will modulate the ERV's capacity to maintain the outside air outlet temperature at setpoint. Note that, when ERV-TEMP-CTRL = FLOAT, there is no active temperature control during normal operation. However, this capacity control mechanism can still be used to prevent condensation and/or frost buildup in the heat-exchanger (see ERV-FROST-CTRL). This keyword is required whenever ERV-TEMP-CTRL is not FLOAT, or when ERV-FROST-CTRL = USE-CAP-CTRL; otherwise it is unused.

TRIM-ECONOMIZER specifies that the economizer dampers will be opened as required to compensate for the ERV's overheating or overcooling effect. The flow through the ERV remains constant; the economizer flow is in addition to the ERV flow. This strategy increases the net fraction of outdoor air in the supply.

Note that this strategy requires that an economizer exist. If an economizer does not exist, then no temperature modulation will take place. Note also that this strategy may not completely eliminate the overheating or overcooling effect, as the economizer may not be able to deliver sufficient supplemental outdoor air. Finally, this strategy is ineffective against any condensation/frost buildup in the heat-exchanger.

BYPASS-OA specifies that a face and bypass damper integral to the ERV will bypass outdoor air as required to compensate for the ERV's overheating or overcooling effect. The total amount of outdoor air remains flowing through the ERV remains constant, however the amount flowing through the heat-exchanger varies.

This strategy does not change the net fraction of outdoor air in the HVAC supply. It is also an effective control strategy against condensation/frost, when the frost occurs in the exhaust air stream (typical for most buildings). It does not work well when the frost occurs in the outdoor air stream (refrigerated warehouses, etc.).

BYPASS-EXHAUST specifies that a face and bypass damper integral to the ERV will bypass exhaust air as required to compensate for the ERV's overheating or overcooling effect. The total amount of exhaust air remains flowing through the ERV remains constant, however the amount flowing through the heat-exchanger varies.

This strategy is effective against condensation/frost, but only when the frost occurs in the exhaust air stream (refrigerated warehouses, etc.). It does not work well when the frost occurs in the exhaust air stream (most typical buildings).

MODULATE-HX specifies that the ERV modulates the resistance of its heat-exchanger. The amount of air flowing through the heat-exchanger remains constant, as does the net fraction of outdoor air in the HVAC supply. A heat wheel achieves this effect by varying the rotational speed of the wheel; the program calculates the required wheel speed. This strategy is effective against condensate/frost, regardless of which side of the heat-exchanger the condensation occurs.

The next set of keywords define the power consumption of various components in the ERV. Heat wheels have a motor that rotates the heat-exchanger. In addition, an ERV may have integral intake and exhaust fans sized to offset the pressure drop of the air flowing through both sides of the heat-exchanger.

ERV-HX-KW

specifies the power consumption of the heat-exchanger. For a heat wheel, this represents the power of the motor that rotates the wheel. The default is the ERV-HX-KW/FLOW multiplied by the design airflow.

ERV-HX-KW/FLOW

like ERV-HX-KW, but specifies the power consumption per unit of flow.

ERV-HX-KW-FPLR

when ERV-CAP-CTRL = MODULATE-HX, accepts the U-name of a curve that modifies the heat-exchanger power consumption as a function of part load ratio. For a heat wheel, the part load ratio is actually the fraction of design wheel speed.

ERV-FANS

accepts a code-word specifying whether an ERV uses its own fans to overcome the pressure drop of the heat-exchange media, or the HVAC supply/return fans.

HVAC-SUPPLY/RETURN the default when an ERV-PURGE is not used, specifies that the pressure drop through the heat-exchanger media is passed on to the supply and return fans of the associated HVAC system. Power consumption of the HVAC fans will be increased in accordance with the pressure drop, fan mechanical efficiency, and presumed fan motor efficiency. Note that this power consumption is in addition to the power consumption of the fans as specified by other keywords (SUPPLY-KW, etc.) .

If the system has a return fan, the intake pressure drop will add to the supply fan, and the exhaust pressure drop will add to the return. Otherwise the pressure drop of both the intake and exhaust sides of the ERV will add to the supply fan energy. Note however, that an ERV system without self-contained fans will almost always have a return fan; otherwise building over-pressurization may be a problem. This over-pressurization may make it difficult to open/close doors. In addition, much of the exhaust air will exfiltrate through the building envelope rather than exhausting through the ERV. The program does not model this effect.

The HVAC fan energy penalty associated with the increased static pressure due to the heat exchanger will be included in the ERV report; *it will not be included in any other report for fan energy.*

SELF-CONTAINED

the default when an ERV-PURGE is used, specifies that the ERV has its own supply and exhaust fans. These fans remove the pressure drop that would otherwise have to be overcome by the HVAC supply/return fans. Since the makeup air passing through the ERV is normally a small fraction of the total HVAC supply flow (10-20% of the total), it is usually more energy efficient to use dedicated fans to move air through the ERV. Otherwise, the much larger airflow of the HVAC fans will be penalized with the ERV pressure drop.

ERV-FAN-EFF

specifies the mechanical efficiency of the ERV fans. For ERV-FANS = SELF-CONTAINED, this applies to both the intake and exhaust fans. For ERV-FANS = HVAC-SUPPLY/RETURN, this value is the presumed efficiency of the HVAC fans.

ERV-MOTOR-CLASS

specifies the motor class (efficiency) of the ERV fans. For ERV-FANS = SELF-CONTAINED, this applies to both the intake and exhaust fans. For ERV-FANS = HVAC-SUPPLY/RETURN, this value is the presumed motor class of the HVAC fans. Acceptable entries are:

STANDARD	specifies a standard motor.
HI-EFF	specifies a NEMA high efficiency motor.
PREMIUM	specifies a NEMA premium efficiency motor. A table presenting motor efficiency vs. motor size and class can be found in the PUMP:MOTOR-CLASS description.

ERV-FAN-KW-FFLOW

when ERV-FANS = SELF-CONTAINED, accepts the U-name of a curve that modifies the hourly fan power consumption as a function of airflow. The default is FC-Fan-w/Dampers.

While hourly airflow through an ERV is usually constant, it may vary in a variable-air volume system having a very high outside air ratio. For example, if the SYSTEM:MIN-OUTSIDE-AIR is 0.8, and the current hourly supply airflow is 60% of design, then the system will be operating with 100% outside air, and the flow ratio through the ERV will be $0.6/0.8 = 0.75$ of design.

This curve will also modify the power consumption of self-contained fans if you have specified the ERV-OA-FLOW, and the actual design make-up air flow of the HVAC system is different than the specified flow. For example, if an ERV selected from the library has an ERV-OA-FLOW = 3000 cfm, and the actual design outside air flow of the HVAC system is 2500 cfm, then the airflow ratio is $2500/3000 = 0.83$.

ERV-OA-KW

when ERV-FANS = SELF-CONTAINED, specifies the power consumption of the outside air makeup fan at the ERV-OA-FLOW. This fan is assumed to be on the inlet side of the heat-exchanger, so that the fan heat is added to the outside air stream prior to entering the heat-exchanger.

If not specified, the design power consumption is either:

$$kW_{Oa} = \text{ERV-OA-KW}/\text{FLOW} * \text{ERV-OA-FLOW}$$

or

$$kW_{Oa} = (\text{ERV-OA-STATIC} * \text{ERV-OA-FLOW}) / (6356. * \text{ERV-FAN-EFF} * f(\text{ERV-MOTOR-CLASS}))$$

If the ERV incorporates a purge, this power consumption will be further modified by the increased static pressure due to the purge flow.

ERV-OA-KW/FLOW

when ERV-FANS = SELF-CONTAINED, specifies the power consumption of the outside air makeup fan, normalized to the ERV-OA-FLOW. This fan is assumed to be on the inlet side of the heat-exchanger, so that the

fan heat is added to the outside air stream prior to entering the heat-exchanger. This keyword is ignored if ERV-OA-KW is also specified.

If not specified, the design power consumption is

$$kW_{oa} = \frac{(ERV-OA-STATIC * ERV-OA-FLOW)}{(6356. * ERV-FAN-EFF * f(ERV-MOTOR-CLASS))}$$

If the ERV incorporates a purge, this power consumption will be further modified by the increased static pressure due to the purge flow.

ERV-OA-STATIC

specifies the static pressure drop of the air flowing through the outside-air side of the heat-exchanger at the ERV-OA-FLOW. This keyword is ignored if the ERV-FANS = SELF-CONTAINED and either the ERV-OA-KW or ERV-OA-KW/FLOW is specified.

If a purge is incorporated, the design static will be increased by the program to account for the purge flow:

$$dP = ERV-OA-STATIC * ERV-OA-FLOW * (1.+ERV-PURGE)**OA-STATIC-EXP$$

ERV-STATIC-EXP

is an exponent that modifies the outside or exhaust static pressure drop as a function of airflow. For example, if the design airflow is 5000 cfm, the actual airflow is 4000 cfm, and this exponent is 1.1, then the actual pressure drop is

$$dP = ERV-OA-STATIC * (4000/5000)**ERV-STATIC-EXP$$

ERV-EXH-KW

when ERV-FANS = SELF-CONTAINED, specifies the power consumption of the outside air makeup fan at the ERV-EXH-FLOW. This fan is assumed to be on the inlet side of the heat-exchanger, so that the fan heat is added to the outside air stream prior to entering the heat-exchanger.

If not specified, the design power consumption is either:

$$kW_{exh} = ERV-EXH-KW/FLOW * ERV-EXH-FLOW$$

or

$$kW_{exh} = \frac{(ERV-EXH-STATIC * ERV-EXH-FLOW)}{(6356. * ERV-FAN-EFF * f(ERV-MOTOR-CLASS))}$$

If the ERV incorporates a purge, this power consumption will be further modified by the increased static pressure due to the purge flow.

ERV-EXH-KW/FLOW

when ERV-FANS = SELF-CONTAINED, specifies the power consumption of the outside air makeup fan, normalized to the ERV-EXH-FLOW. This fan is assumed to be on the inlet side of the heat-exchanger, so that the fan heat is added to the outside air stream prior to entering the heat-exchanger. This keyword is ignored if ERV-EXH-KW is also specified.

If not specified, the design power consumption is

$$\text{kW}_{\text{exh}} = (\text{ERV-EXH-STATIC} * \text{ERV-EXH-FLOW}) / (6356. * \text{ERV-FAN-EFF} * f(\text{ERV-MOTOR-CLASS}))$$

If the ERV incorporates a purge, this power consumption will be further modified by the increased static pressure due to the purge flow.

ERV-EXH-STATIC

specifies the static pressure drop of the air flowing through the outside-air side of the heat-exchanger at the ERV-EXH-FLOW. This keyword is ignored if the ERV-FANS = SELF-CONTAINED and either the ERV-EXH-KW or ERV-EXH-KW/FLOW is specified.

The next set of keywords define the method used to counteract the condensation and/or frost that may accumulate on the heat-exchanger surface. Just as a cooling coil dehumidifies air by cooling the air below its dewpoint, an ERV can also develop condensation in one of its air streams if the other air stream is sufficiently cold. Condensation may allow undesirable mold and bacteria to grow on the heat-exchanger surface. The condensation will freeze on the heat-exchanger surface if the surface is sufficiently cold. Frost may build up to the point where the heat-exchanger passages are completely blocked. In addition, the weight of the frost may damage the heat-exchanger.

In typical buildings, condensation/frost is most likely to occur during very cold outdoor conditions. The cold outdoor air entering the ERV can cool the warm, humid exhaust air to below the exhaust air's dewpoint. Buildings with large latent loads or humidification systems are most likely to have problems. Sensible-only ERVs have a greater problem with condensation than enthalpy ERVs. An enthalpy ERV simultaneously cools and dries the humid exhaust air, thereby lowering its dewpoint.

Refrigerated warehouses and ice rinks can also experience problems with condensation/frost, but in the opposite mode of operation. In these applications, the cold exhaust air can cause the warmer, humid outdoor air to condense. The physics are the same as before, but the method used to eliminate the condensation may be different.

ERV-FROST-CTRL

accepts a code-word defining the condensate/frost control methodology.

NONE	the default, specifies that no condensate/frost control sequence is used. The program will report the number of hours in which condensate and/or frost occurs.
PREHEAT-OA	specifies that a preheat coil located in the entering outdoor air stream will heat the air. The preheat temperature may be either fixed, or reset to the temperature required prevent condensation. Preheating the outdoor air works best when the condensation is occurring in the exhaust air stream (conventional building). This strategy also works for condensation in the outdoor air stream (refrigerated building), but requires 2-3 times as much energy as the PREHEAT-EXHAUST strategy to achieve the same effect.
PREHEAT-EXHAUST	specifies that a preheat coil located in the entering exhaust air stream will heat the air. The preheat temperature may be either fixed, or reset to the temperature required to prevent condensation. Preheating the exhaust air works best when the condensation is occurring in the outdoor air stream (refrigerated building). This strategy also works for condensation in the exhaust air stream (conventional building), but requires 2-3 times as much energy as the PREHEAT-OA strategy to achieve the same effect.

USE-CAP-CTRL

specifies that the control sequence specified in ERV-CAP-CTRL to control the outside-air outlet temperature will also be used to control condensation/frost. The capacity control sequence will modulate as required deliver the temperature exactly required to avoid condensation. The efficacy of condensate/frost control will vary according to the ERV-CAP-CTRL method:

a) ERV-CAP-CTRL = TRIM-ECONOMIZER has no effect on condensation/frost. This strategy simply varies the supplemental flow of air through the economizer. Since the outdoor and exhaust flows through the heat-exchanger are unchanged, this strategy has no impact on condensation.

b) ERV-CAP-CTRL = BYPASS-OA works well for conventional buildings where the exhaust-air stream is warm and humid, and the outdoor-air stream is cold. When condensation is detected in the exhaust stream, the normal temperature control, if any, is overridden and outdoor air is bypassed around the heat-exchanger, reducing the flow of outdoor air through the heat-exchanger. This outdoor air reduction allows the exhaust air stream to remain warmer, thereby avoiding condensation.

This strategy does not work for refrigerated warehouses, ice rinks, etc., where condensation usually occurs in the outdoor-air stream, rather than the exhaust. Bypassing outdoor air in these buildings will make the outdoor-air stream through the heat-exchanger even colder; BYPASS-EXHAUST should be used instead.

c) ERV-CAP-CTRL = BYPASS-EXHAUST works well for refrigerated warehouses, etc., where the outdoor-air stream is warm and humid, and the exhaust-air stream is cold. When condensation is detected in the outdoor-air stream, the normal temperature control, if any, is overridden and exhaust air is bypassed around the heat-exchanger. This exhaust air reduction allows the outdoor-air stream to remain warmer, thereby avoiding condensation.

This strategy does not work for conventional buildings where condensation usually occurs in the exhaust-air stream. Bypassing exhaust air in these buildings will make the exhaust-air stream through the heat-exchanger even colder; BYPASS-OA should be used instead.

d) ERV-CAP-CTRL = MODULATE-HX works well for both conventional and refrigerated buildings. Reducing the speed of a heat wheel will reduce the heat transfer between the air streams, thereby raising the outlet temperature of the warmer air stream and avoiding condensation.

ERV-PREHEAT-CTRL

when ERV-FROST-CTRL = PREHEAT-OA or PREHEAT-EXHAUST, specifies the preheat temperature control strategy:

FIXED-SETPT

the default, specifies that the air will be preheated to a fixed temperature, regardless of the actual hourly requirements. If set too low, condensation may occur anyway. If set too high, energy will be wasted and the efficiency of the ERV reduced.

RESET-SETPT specifies that the air will be preheated to the exact temperature necessary to eliminate condensation. This temperature will vary hourly depending on the temperature and humidity of the outdoor and exhaust air streams.

ERV-PREHEAT-T

when `ERV-PREHEAT-CTRL = FIXED-SETPT`, specifies the preheat setpoint temperature. The required temperature is a function of the type of building, latent loads, sensible vs. enthalpy exchange, and whether the preheat is in the outdoor or exhaust air streams. Manufacturer's literature provides more information on this subject.

ERV-PREHEAT-SRC

when `ERV-FROST-CTRL = PREHEAT-OA` or `PREHEAT-EXHAUST`, accepts a code-word specifying the type of preheat coil:

HOT-WATER the default when the `SYSTEM:HEAT-SOURCE = HOT-WATER`, specifies a hot-water coil.

ELECTRIC the default for all other situations, specifies an electric preheat coil.

PREHEAT-AIR-DT

when `ERV-FROST-CTRL = PREHEAT-OA` or `PREHEAT-EXHAUST`, specifies the design air temperature rise through the preheat coil. The program calculates the design size of the preheat coil based on this rise and the ERV's design airflow.

PREHEAT-HW-DT

when `ERV-PREHEAT-SRC = HOT-WATER`, specifies the design water temperature drop through the preheat coil. The program calculates the design preheat water flow based on this value and the design preheat coil capacity.

PREHEAT-INLET-DT

when `ERV-PREHEAT-SRC = HOT-WATER`, specifies the design temperature differential between the hot-water entering the preheat coil, and the air entering the preheat coil. The program uses this value in a simple linear relationship to vary the hourly flow as a function of coil load and temperatures.

Evaporative Cooling Units

EVAP-CL-TYPE

For `SYSTEM:TYPE = EVAP-COOL` or for an add-on unit, takes a code-word that specifies the type of evaporative cooling elements. See Figure 38.

DIRECT There is only a direct evaporative cooling element.

INDIRECT There is only an indirect evaporative cooling element.

INDIRECT-DIRECT There are both direct and indirect evaporative cooling elements.

EVAP-CL-AIR

Fraction of the design supply air flow that passes through the evaporative cooler for add-on units. Among other things, it is used to size the evaporative cooler. The usual choices for `EVAP-CL-AIR` would be these:

Allow `EVAP-CL-AIR` to default; then it will be set equal to the minimum outside air ratio for the system as shown in Figure 39. Set `EVAP-CL-AIR = 1.0`; then all of the supply air will pass through the evaporative cooler. If `EVAP-CL-AIR` is less than or equal to the minimum outside air ratio, only outside air will flow through the evaporative cooler, as shown in Figure 38.

If EVAP-CL-AIR is greater than the minimum outside air ratio, all of the outside air plus some of the return air will flow through the evaporative cooler, as shown in Figure 39. The economizer keywords (OA-CONTROL and DRYBULB-LIMIT) and outside air control operate just as if the evaporative cooler were not there, except that the outside air flow does not go to minimum when OA-CONTROL=TEMP and the outside air temperature is above the return air temperature, but below DRYBULB-LIMIT. For example, for OA-CONTROL = TEMP, DRYBULB-LIMIT = 100F (37.8C), and EVAP-CL-LIMIT-T = 100F (37.8C), if the outside dry-bulb is above 100F (37.8C), the outside air flow will go to minimum, the evaporative cooler will be off, and all cooling will be done conventionally. If the outside dry-bulb is below 100F (37.8C) but above the needed supply air temperature, the system will use 100% outside air and the evaporative cooler will operate. If the outside dry-bulb is below the supply temperature, cooling will be done by outside air only. When the full capacity of the evaporative cooler is not needed to cool the mixed air to the needed supply air temperature, the evaporative cooler is assumed to cycle on and off to meet the partial load. You can specify the minimum outside air with the keyword MIN-OUTSIDE-AIR. Note, however, that the ZONE keywords OUTSIDE-AIR-FLOW, OA-FLOW/PER, and OUTSIDE-CHANGES, when input, take precedence over MIN-OUTSIDE-AIR.

EVAP-CL+M-SUP

Takes a code-word that specifies whether the evaporative precooling can or cannot operate in conjunction with mechanical cooling. In either case the evaporative cooler will cycle off if OA-CONTROL = TEMP and the outside air is cool enough to handle the entire cooling load.

SEPARATE	The evaporative cooler operates only when it meets the entire cooling load.
TOGETHER	The evaporative cooler does as much cooling as possible; mechanical cooling handles the remaining load (plus any dehumidification that is needed).

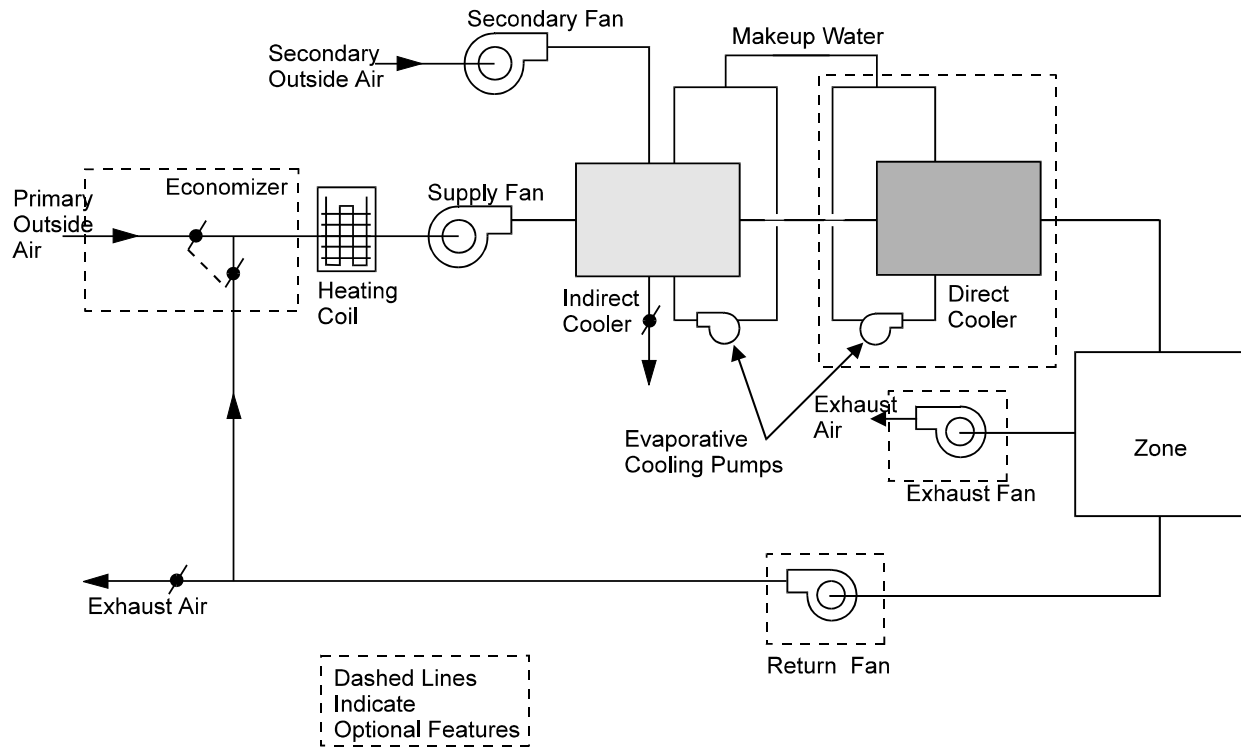

Figure 38 Stand-alone evaporative cooler system (SYSTEM: TYPE = EVAP-COOL)

EVAP-CL+REC-RA

Accepts a code-word that specifies whether return air (YES) or outside air (NO) is used for the secondary airstream of the indirect cooler.

YES Return air is used for the secondary air stream of the indirect cooler.

NO Outside air is used for the secondary air stream of the indirect cooler.

When EVAP-CL+REC-RA = YES, RECOVERY-EFF simulates heat exchange between return air and outside air (during heating periods). Figure 38 and Figure 39 illustrate EVAP-CL+REC-RA = NO.

EVAP-CL-KW/FLOW

The power per unit flow required by the evaporative cooling pump and secondary fan. For add-on evaporative cooling you should increase the supply fan static pressure to compensate for the added pressure drop through the indirect/direct exchangers.

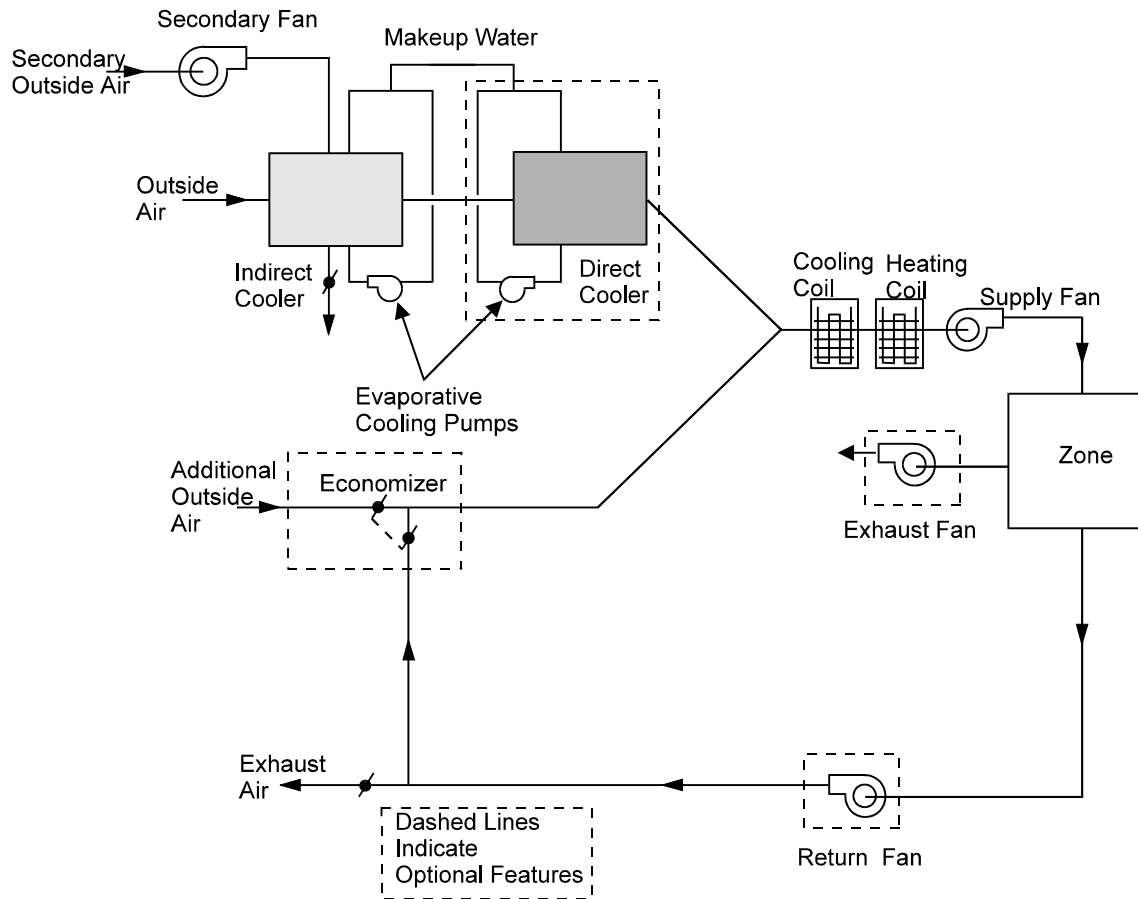

Figure 39 Add-on evaporative cooling unit in which only outside air is passed through the evaporative cooler (EVAP-CL-AIR allowed to default), shown integrated with a conventional HVAC system.

DIRECT-EFF

Rated nominal effectiveness of the direct evaporative cooler. For variable-volume systems, this value is modified by a default curve of effectiveness vs. flow (which can be overridden using DIRECT-EFF-FFLOW).

DIRECT-EFF-FFLOW

For variable-volume systems, takes the U-name of a quadratic curve that modifies the rated effectiveness of the direct evaporative cooling element as a function of the flow rate.

INDIR-EFF

Rated effectiveness of the indirect evaporative cooler. For variable-volume systems, this value is modified by a default curve of effectiveness vs. flow (which can be overridden using INDIR-EFF-FFLOW).

INDIR-EFF-FFLOW

For variable-volume systems, takes the U-name of a quadratic curve that modifies the rated effectiveness of the indirect evaporative cooling element as a function of flow rate.

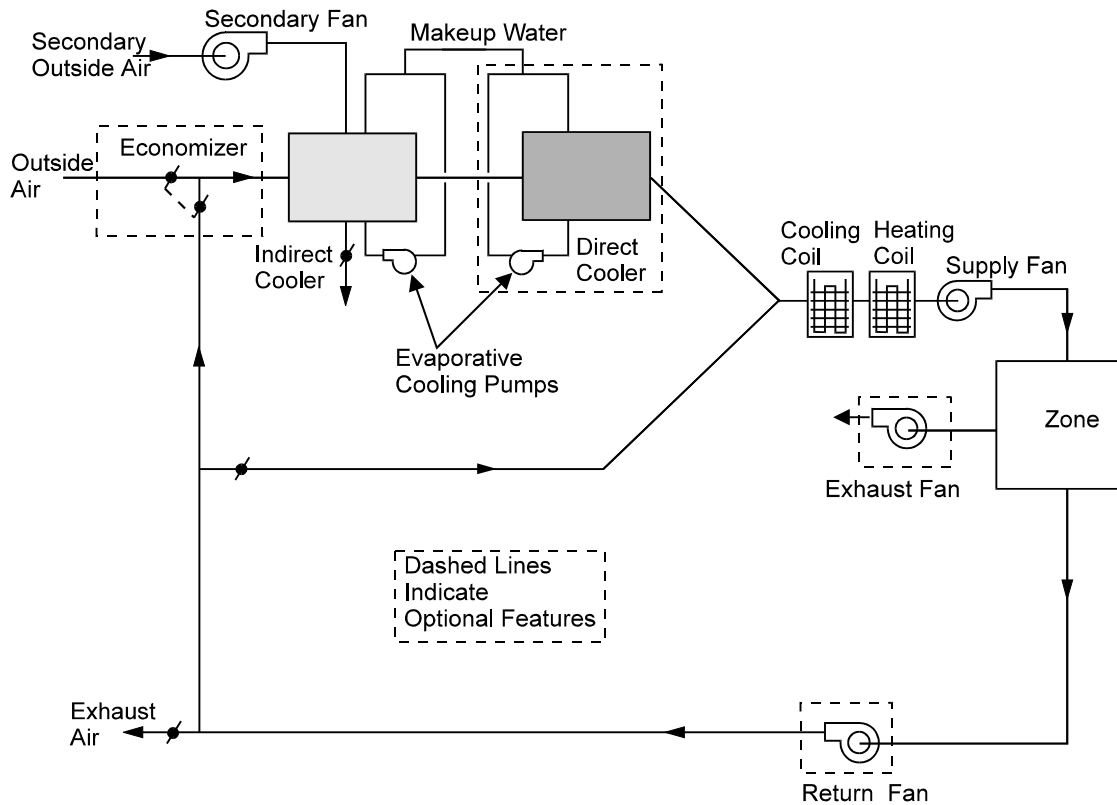

Figure 40 Add-on evaporative cooling unit in which some of the return air passes through the evaporative cooler (EVAP-CL-AIR > MIN-OUTSIDE-AIR), shown integrated with

EVAP-CL-LIMIT-T

Outside air dry-bulb temperature above which the evaporative cooler will be turned off. In very hot weather (above 120F (48.9C)), it is sometimes more energy efficient to revert to mechanical cooling alone rather than evaporative cooling supplemented by mechanical cooling.

RES-EVAP-COOLER

For SYSTEM:TYPE = RESYS, takes a codeword that indicates whether an evaporative cooling unit is present. YES and NO (the default) If RES-EVAP-COOLER = YES, it is assumed that mechanical cooling is not present.

NO There is no evaporative cooling unit.

YES There is an evaporative cooling unit. In this case it is assumed that there is no mechanical cooling.

Note that if RES-EVAP-COOLER = YES, natural ventilation through open windows, if specified, can be active.

RES-EVAP-CL-FLOW

For SYSTEM:TYPE = RESYS, this is the air-side capacity of the evaporative cooler. This keyword is required if RES-EVAP-COOLER = YES. Note that the air flow for heating is sized automatically and, since it is determined by the peak heating load, it may differ from RES-EVAP-CL-FLOW.

Natural Ventilation

The following "VENT" keywords apply to natural ventilation through open windows. They apply only to system TYPE = RESYS, RESYS2, PSZ, PVVT and EVAP-COOL.

VENT-METHOD

Takes a code-word that specifies how the natural ventilation rate is to be calculated. Allowed values are:

- AIR-CHANGE You specify the ventilation air changes per hour by using the keyword NATURAL-VENT-AC. This sets a fixed air change rate that applies whenever the windows are open. The air change rate is not a function of windspeed or inside-outside temperature difference.

- S-G Stands for "Sherman-Grimsrud" method in which the air change rate depends on wind speed, inside-outside temperature difference, and wind shielding of the building. In this case, the keywords MAX-VENT-RATE, HOR-VENT-FRAC, and FRAC-VENT-AREA are applicable.

VENT-TEMP-SCH

Takes the U-name of a SCHEDULE of TYPE = TEMPERATURE that gives the hourly minimum temperature setpoint for the natural venting algorithm. The windows are assumed to be closed if the temperature in the room falls below this point. This temperature is generally below the zone cooling thermostat setpoint given by COOL-TEMP-SCH. If VENT-TEMP-SCH is not specified all its hourly values will default to the temperature at the top of the heating throttling range as defined by HEAT-TEMP-SCH. This keyword is also used for forced ventilation when NIGHT-VENT-CTRL = SCHEDULED+DEMAND. In this case the night venting fan operates only if the temperature of any conditioned zone on the system is above the VENT-TEMP-SCH value.

NATURAL-VENT-SCH

Takes the U-name of a SCHEDULE of TYPE = ON/OFF or ON/OFF/FLAG that determines when the windows can be open vs. when they are closed. The allowed hourly values in the schedule are 0, 1 and -1.

A value of 0 means that the windows are always closed for the hour.

A value of 1 means that the occupants will open the windows for all or part of the hour if natural ventilation can provide enough cooling to keep the zone temperature within or below the throttling range associated with COOL-TEMP-SCH. (The lowest the temperature is allowed to go in this case is the VENT-TEMP-SCH value for the hour.)

A value of -1 means that the occupants will open the windows for all or part of the hour if the condition for the value of 1 is met and the enthalpy of the outside air is lower than the enthalpy of the inside air. In this case the zone may be cooled down to the VENT-TEMP-SCH schedule for the hour.

As an example, assume that the occupant arises at 6:00 A.M., goes to work at 8:00 A.M., returns from work at 5:00 P.M., and retires at 10:00 P.M. every day of the year. The schedule describing the window management would be:

```

VENT-1 = SCHEDULE
TYPE ON/OFF
THRU DEC 31 (ALL) ( 1, 6 ) (0)
                  ( 7, 8 ) (1)
                  ( 9,17 ) (0)
                  (18,22) (-1)
                  (23,24) (0) . .
    
```

```
TheSystem = SYSTEM
  NATURAL-VENT-SCH = VENT-1
  . . . .
```

If the values in VENT-1 during the sleeping hours were 1's, it would imply that the occupant got out of bed to open and close the windows whenever the conditions called for it.

To specify temperature limits for cooling by natural ventilation, specify VENT-TEMP-SCH. For example, suppose the schedule

```
MECH-COOL-TEMP = SCHEDULE
  TYPE                TEMPERATURE
  THRU DEC 31 (ALL)  ( 1, 8) (78)
                   ( 9,17) (85)
                   (18,24) (78) . .
```

describes the cooling set point of the mechanical system, while the schedule

```
MIN-VENT-TEMP = SCHEDULE
  TYPE                TEMPERATURE
  THRU DEC 31 (ALL)  ( 1, 6) (60)
                   ( 7,22) (68)
                   (23,24) (60) . .
```

gives the minimum temperature below which the windows will be closed. Then under ZONE, specify COOL-TEMP-SCH = MECH-COOL-TEMP, and under SYSTEM, specify VENT-TEMP-SCH = MIN-VENT-TEMP.

The following table summarizes this example.

Schedule Hours	Temperature Range*
1,6 (midnight to 6 am)	78F max (provided by mechanical cooling)
7,8 (6 am to 8 am)	78F max (provided by mechanical cooling) 68F min (provided by occupant operating windows)
9,17 (8 am to 5 pm)	85F max (provided by mechanical cooling)
18,22 (5 pm to 10 pm)	78F max (provided by mechanical cooling) 68F min (provided by occupant operating windows)
23,24 (10 pm to midnight)	78F max (provided by mechanical cooling)
* Note that during the hours when the windows are constantly closed (10 pm to 6 am and 8 am to 5 pm), the temperatures referenced by VENT-TEMP-SCH are meaningless. Note also that VENT-TEMP-SCH does not necessarily say that cooling by natural ventilation will be done (that is accomplished by NATURAL-VENT-SCH). VENT-TEMP-SCH only sets the minimum indoor temperature limits for natural ventilation. The conditions specified in NATURAL-VENT-SCH determine when and if cooling by natural ventilation is done.	

The FAN-SCHEDULE controls the availability of natural ventilation. The fan must be scheduled on in order for the program to calculate an extraction rate that, in turn, is used to signal when natural ventilation is needed to cool the zone. When natural ventilation is not sufficient to hold the zone thermostat setpoint, the program reverts to mechanical cooling.

NATURAL-VENT-AC

The peak number of air changes per hour due to natural ventilation through open windows. This value is constant and is not a function of wind speed.

NATURAL-VENT-KW

The kW of the natural ventilation assisting fan (otherwise known as a whole house fan). This value is entered when a whole house fan is used to perform the natural cooling; the value entered is the kW used by the fan during a full hour of operation. The hour value is calculated as this value times the runtime of the fan during the hour; the runtime is calculated assuming the fan is operated to maintain the VENT-TEMP-SCH with a flow of NATURAL-VENT-AC.

MAX-VENT-RATE

The maximum air change rate for VENT-METHOD = S-G. For high wind speeds, the Sherman-Grimsrud model can give unrealistically large ventilation rates; MAX-VENT-RATE eliminates this problem.

OPEN-VENT-SCH

Takes the U-name of a SCHEDULE (of TYPE=FRACTION) with hourly values of the probabilities that the windows will be opened given that the conditions set by NATURAL-VENT-SCH and VENT-TEMP-SCH are met and that the windows were not already open. For example, you can set a low probability that the windows will be opened when the occupants would normally be asleep and a high probability that they will be opened when the occupants arise in the morning. Used for either VENT-METHOD = AIR-CHANGE or VENT-METHOD = S-G.

HOR-VENT-FRAC

For VENT-METHOD = S-G, the fraction of venting area that is in the floor and ceiling. It is used to calculate the stack effect contribution to natural ventilation. Unless there are openable skylights or clerestory windows or an open fireplace flue, this keyword can be allowed to default to zero.

FRAC-VENT-AREA

For VENT-METHOD = S-G, this is 0.6 times the open window area divided by the floor area.

Airside Control

The following keywords provide information on supply air temperature set point, control strategy, and limits, humidity limits, and equipment operating schedules.

MAX-SUPPLY-T

The maximum allowable temperature (i.e., maximum diffuser temperature) of the air delivered to the zones in a system. MAX-SUPPLY-T and DESIGN-HEAT-T are used to size the supply air flow rate and the capacity of the heating coil. MAX-SUPPLY-T, which should be greater than DESIGN-HEAT-T, is also used as an upper limit for supply air temperature control.

This entry is mandatory for certain types of systems (e.g., RESYS, MZS, DDS, SZCI, UVT, UHT, HP, HVSYS, FC, IU, PSZ, PMZS, PTAC) and optional for other types of systems (SZRH, VAVS, RHFS, CBVAV, PAVS). If no entry is made, the program will use the sum of MIN-SUPPLY-T and REHEAT-DELTA-T.

MIN-SUPPLY-T

For systems that can provide cooling, this is a required keyword that gives the minimum temperature of the air delivered to the zone. MIN-SUPPLY-T and COOL-DESIGN-T are used to size the capacity of the cooling coil and supply air flow rate. The supply air flow rates needed to satisfy the heating and cooling requirements are compared and the greater of the two quantities is used for the system air flow rate. Note that MIN-SUPPLY-T also controls the amount of moisture that can be removed by the cooling coils.

Note, that for those systems that are to maintain a constant cooling air discharge temperature (see keyword COOL-CONTROL), the control set point is determined by the value entered for COOL-SET-T rather than MIN-SUPPLY-T. In this case, the program uses MIN-SUPPLY-T to limit subcooling for dehumidification purposes (and to calculate the design air flow rate for cooling).

Fan Availability

FAN-SCHEDULE

Takes the U-name of a schedule (TYPE=ON/OFF/FLAG) that indicates when the system's fans (supply, return, and exhaust) are on or off. If not entered the program assumes the fans are always available when needed. The schedule values have the following meaning:

If the value is 1, the fans are on.

If the value is 0, the fans are off but may be turned on by NIGHT-CYCLE-CTRL if zone temperatures warrant it.

If the value is -1, the fans are not permitted to be on for any reason.

A value of -999 defines an optimum start period of up to six hours. During this period the fan start time is delayed until the fan run time matches that needed to meet the desired zone temperatures. Notice that this decision is made on an hourly basis, whereas in the real world it is made on much smaller increments (ten minutes or less). For the hourly calculation, the number of hours needed to bring each zone on the system up or down to its set point is estimated. If the number of such hours for the majority of the zones is equal to or greater than the number of hours remaining in the start period, the fans are turned on. The target zone temperatures used in the calculation are the heating and cooling set point temperatures given in HEAT-TEMP-SCH and COOL-TEMP-SCH that correspond to the first hour following the scheduled optimum start period.

Example input:

Optimum start input for FAN-SCHEDULE:

```
FAN-OPT-SCH-1 = SCHEDULE
  TYPE                = ON/OFF/FLAG
  THRU DEC 31         (WD) (1,5) (0) (6,7) (-999) (8,18) (1) (19,24) (0)
                      (WEH) (1,24) (0) . .
```

Notes on optimum start simulation:

The optimum start period must be less than or equal to six hours.

The fan must be scheduled on using the value 1 for the first hour following the optimum start period.

An optimum start period must be defined within a contiguous set of hours. Therefore, the optimum start period cannot begin before 1:00 am. For example, the following is not valid:

```
(1,4) (-999) (5,18) (1) (19,22) (0) (23,24) (-999)
```

Zones with Trombe walls should not be used with optimum start.

Optimum start will not work well on systems serving zones that are not evenly balanced with respect to their start up duration.

If the system is under-sized, or cannot supply sufficient air at its minimum or maximum supply temperature, the start time will be delayed too long and there will be excessive hours reported with loads not met. A VAV system with a low MIN-FLOW-RATIO and a thermostat type that is not REVERSE-ACTION fits this description.

Results for run periods of just a few days will be poorer those for longer run periods since the program attempts to learn (simulating feedback) to improve on its estimating abilities.

During hours of the optimum start period in which the fan has not been started, the system will behave as if the fan schedule that hour were (0). Thus, the fan can cycle on during this period if NIGHT-CYCLE-CTRL is used.

For air-to-air heat pumps, where the primary interest is minimizing the use of electric resistance heating during start-up, it is suggested that the set point temperature be ramped upward. This should start with the first hour during a normal fan start period.

HFAN-SCHEDULE

For the hot-deck fan of a multizone or dual-fan dual-duct system, takes the U-name of a schedule (TYPE=ON/OFF/FLAG) whose values specify the operation of the fan. If HFAN-SCHEDULE is not specified, the hot-deck fan will operate according to FAN-SCHEDULE. Normal entries are 0.0 to indicate the fan is off, and 1.0 to indicate the fan is on. However, if a non-zero number is entered in place of 1.0, it is assumed that the hot deck fan will run whenever the air temperature is less than the schedule value, and will shut off whenever the outdoor temperature is higher than this value. This allows hot deck fan energy to be saved whenever it appears that heating will not be required. This capability is not extended to the cold deck fan, as the cold deck fan must always run during occupied hours to provide the outdoor air required for ventilation. A value of -999 may be entered to indicate that optimum start is to be used. In this case, a value of -999 must also be entered for the same hours in the cold deck fan schedule. The hot and cold deck fans will start simultaneously during the optimum start periods. In other words, the program cannot use optimum start to start only the hot deck fan during warmup periods. Note that the hot deck fan can be started independently of the cold deck fan by using the regular schedule values.

EXHAUST-FAN-SCH

Accepts U-name of a schedule (TYPE = ON/OFF or FRACTION) that specifies the hours of operation of the system exhaust fans. A zero value indicates that the exhaust fans are off. A non-zero value indicates the exhaust fans are on. A value between zero and one indicates that the exhaust is variable, such as for a manually-controlled toilet exhaust fan, or a laboratory fume hood. The exhaust fans can only operate when the main fans are on (FAN-SCHEDULE is positive or the system fans have cycled on). If the EXHAUST-FAN-SCH is not specified, it defaults to FAN-SCHEDULE.

Cooling Availability and Supply Temperature

COOLING-SCHEDULE

Takes the U-name of a SCHEDULE of TYPE = ON/OFF/TEMP that specifies when cooling is available from the system. If not entered, the program will assume that cooling is always available when needed. A zero value for this schedule means that cooling is not available except possibly by outside air via the economizer. A non-zero value indicates that cooling is available. The program interprets a value greater than 1.0 to be the outside temperature below which cooling is unavailable. The program assumes the heating coils are off whenever the air-handling fans are off.

COOL-CONTROL

Takes a code-word that specifies how the air temperature leaving the system cooling coil is controlled. Allowed values are:

CONSTANT The supply air temperature is held nearly constant at COOL-SET-T; it can change a few degrees due to fan heat and throttling range of the temperature controller.

WARMEST Sets the cooling coil (cold deck) temperature each hour to adequately cool the zone with the highest temperature. The limits on the supply air temperature are then governed by COOL-MAX-RESET-T, COOL-MIN-RESET-T, coil capacities, and cooling schedules.

WARNING: If using the COLDEST or WARMEST options in conjunction with a variable air volume system, there are two actions within the throttling range. To reflect reality and to prevent instability in the simulation, THROTTLING-RANGE should be increased to 4-6F (2-3K).

RESET Specifies use of COOL-RESET-SCH for control of heating and/or cooling air supply temperature, based on outdoor air temperature.

SCHEDULED Specifies use of COOL-SET-SCH for control of heating and/or cooling air supply temperature.

COOL-SET-T

The cooling air supply temperature setpoint when COOL-CONTROL = CONSTANT. Note that even though COOL-SET-T determines the cooling air supply temperature, the program uses MIN-SUPPLY-T to calculate the design supply air flow rate.

COOL-CTRL-RANGE

Throttling range of the cooling coil controller. It equals Tmax - Tmin where Tmax is the temperature of the coil when it is fully loaded and Tmin is the temperature of the coil when it is fully unloaded.

COOL-SET-SCH

Takes the U-name of a SCHEDULE of cooling air supply setpoint temperatures when COOL-CONTROL = SCHEDULED. The SCHEDULE should be have TYPE = TEMPERATURE.

Example input:

```

COOL-COIL-SCH = SCHEDULE
  TYPE          = TEMPERATURE
  THRU APR 30   (ALL) (1,24) (60)
  THRU SEP 30   (ALL) (1,24) (55)
  THRU DEC 30   (ALL) (1,24) (60) ..

SYS-1 = SYSTEM
  COOL-CONTROL = SCHEDULED
  COOL-SET-SCH = COOL-COIL-SCH
  . . . .
    
```

COOL-RESET-SCH

When COOL-CONTROL = RESET, takes the U-name of a SCHEDULE of TYPE = RESET-TEMP that defines the relationship between cooling air temperature and outside air temperature, and specifies the days of the year during which this relationship applies.

COOL-MAX-RESET-T

When COOL-CONTROL = WARMEST, specifies the maximum temperature to which the supply air temperature resets during cooling. Of course, higher temperatures may be achieved if the available cooling capacity is inadequate or if cooling is scheduled off.

For dual-duct and multizone systems, this value is also used in the design calculations to calculate the design heating and cooling air flows to each zone. For the peak heating air flow calculation, any cold duct air flowing at the minimum cooling air flow ratio is assumed to enter the zone at this temperature unless COOL-CONTROL = CONSTANT.

COOL-MIN-RESET-T

When COOL-CONTROL = WARMEST, specifies the minimum temperature to which the supply air temperature resets during cooling. Of course, lower temperatures may be achieved if the available heating capacity is inadequate, or if heating is scheduled off.

RESET-PRIORITY

Takes a code-word that specifies how the supply-air temperature is reset when COOL-CONTROL = WARMEST or HEAT-CONTROL = COLDEST. In previous versions of the program an "air flow first" priority was used in which the supply air temperature was reset only when the zone temperature was in the bottom half of the cooling throttling range. This caused air flow to be reduced first, before the supply air temperature. For example, if a zone cooling setpoint is 76F with a 2F throttling range, the air flow will first modulate in the range of 77F to 76F and the supply air temperature will reset in the range of 76F to 75F. This approach minimizes air flow and fan energy, at the possible expense of cooling energy.

AIRFLOW-FIRST	Simulates the above "air flow first" control in which the air flow and fan energy are reduced before the supply temperature is reset.
TEMP-FIRST	Reverses the priority so that the supply temperature is reset prior to any reduction in air flow. This approach minimizes cooling loads at the expense of fan energy. Note, however, that fan energy can be a significant portion of the annual cooling energy (fan power shows up as fan heat). As a result, this strategy may give disappointing results in many cases.
SIMULTANEOUS	Causes the supply temperature to be reset simultaneously with a reduction in air flow. It is a compromise between the AIRFLOW-FIRST and TEMP-FIRST strategies.

MIN-RESET-FLOW

When COOL-CONTROL = WARMEST and RESET-PRIORITY = AIRFLOW-FIRST, specifies the minimum fraction of design zonal airflow at which the reset supply temperature is calculated. This keyword acts as a lower limit for a zone's MIN-FLOW-RATIO when calculating the required supply air temperature. This keyword prevents a zone with a very low MIN-FLOW-RATIO from dominating the COOL-CONTROL=WARMEST reset controller. In other words, the required supply temperature to a zone will be calculated assuming the zone is at the greater of the MIN-RESET-FLOW or its MIN-FLOW-RATIO. It has no other effect; specifically it has no influence over the actual MIN-FLOW-RATIO of a zone.

The actual airflow used in the supply reset calculation is the greater of this value or the zone's MIN-FLOW-RATIO.

Heating Availability and Supply Temperature

HEATING-SCHEDULE

Takes the U-name of a SCHEDULE of TYPE = ON/OFF/TEMP that specifies when heating is available from the system. If not entered, the program will assume that heating is always available when needed. A zero value for this schedule means that heating is not available. A non-zero value indicates that heating is available. The program interprets a value greater than 1.0 to be the outside temperature above which heating is unavailable. The program assumes the heating coils are off whenever the air-handling fans are off.

HEAT-CONTROL

Takes a code-word that specifies how the air temperature leaving the system heating coil is controlled. Allowed values are:

CONSTANT	The supply air temperature is held nearly constant at HEAT-SET-T; it can change a few degrees due to fan heat and throttling range of the temperature controller.
COLDEST	Sets the heating coil (hot deck) temperature each hour to adequately heat the zone with the lowest temperature. The limits on the supply air temperature are governed by coil capacities, heating schedules, and MAX-SUPPLY-T. WARNING: If using the COLDEST or WARMEST options in conjunction with a variable air volume system, there are two actions within the throttling range. To reflect reality and to prevent instability in the simulation, THROTTLING-RANGE should be increased to 4-6F (2-3K).
RESET	Specifies use of HEAT-RESET-SCH for control of heating air supply temperature based on outdoor air temperature.
SCHEDULED	Specifies use of HEAT-SET-SCH for control of heating air supply temperature.

In SYSTEM TYPEs VAVS, RHFS, PAVS, and PIU the HEAT-CONTROL keyword is activated when COOL-CONTROL is set equal to WARMEST and a central heating coil has been specified by giving HEAT-SET-T a value greater than MIN-SUPPLY-T; in this case the only non-ignored value for HEAT-CONTROL is COLDEST. When coldest/warmest control is specified the controller first looks to see if any ZONE has a cooling demand; if there is a ZONE cooling demand the AHU discharge temperature is reset to attempt to just satisfy the ZONE with the largest cooling demand. If no ZONE has a cooling demand the controller looks to satisfy the ZONE with the greatest heating demand but without forcing any ZONE into creating a cooling demand. If neither a heating or cooling demand is found for any ZONE mixed air is passed.

HEAT-SET-T

For systems that use HEAT-CONTROL (MZS, DDS, PMZS), this is the supply air temperature setpoint when HEAT-CONTROL = CONSTANT; the default is MAX-SUPPLY-T. For variable-volume systems, specifying HEAT-SET-T enables a main air-handler heating coil; the value in this case is the maximum temperature off of this coil. For single duct systems (VAVS, PAVS and PIU), the default is MIN-SUPPLY-T (indicating no central heating coil).

On occasion, you may not want the control point of the hot deck to be equal to MAX-SUPPLY-T. A variable-volume system has the potential of supplying 100% outside air (and therefore cold air) to the zone VAV box. Preheat will raise the supply temperature up to PREHEAT-T, but only the main heating coil can hold a constant supply air temperature or the modified temperature of a WARMEST or RESET controller. Use of HEAT-SET-T for systems SZRH and PSZ is discouraged because it simply overrides the maximum leaving air temperature specified by MAX-SUPPLY-T.

HEAT-SET-SCH

For HEAT-CONTROL = SCHEDULED, takes the U-name of a SCHEDULE of TYPE = TEMPERATURE that specifies the hot deck temperature.

HEAT-RESET-SCH

For HEAT-CONTROL = RESET, takes the U-name of a SCHEDULE (TYPE=RESET-TEMP) that gives the relationship between hot deck temperature and outside air temperature.

HEAT-MIN-RESET-T

Minimum temperature to which the supply air temperature resets during heating when HEAT-CONTROL = COLDEST. Of course, lower temperatures may be achieved if the available heating capacity is inadequate or if heating is scheduled off. Also, this reset temperature may not be achieved (heating supply temperature warmer than this value) depending on the temperature of the return air and/or outdoor air.

For dual-duct and multizone systems, this value is also used in the design calculations to calculate the design heating and cooling air flows to each zone. For the peak heating air flow calculation, any hot duct air flowing at the minimum heating air flow ratio is assumed to enter the zone at this temperature, unless HEAT-CONTROL = CONSTANT.

Humidity Control**MAX-HUMIDITY**

The highest allowable relative humidity in the return air from zones served by the system. Because the program calculates the relative humidity in the return air, dehumidification is based on the average humidity condition for all the zones served by the system, as weighted by the relative return air flow rate from each zone. This data entry should be used only for those systems that have the components required for control of excess humidity (i.e., a humidistat and a heating coil downstream of the cooling coil). If not entered, the program will assume that humidity control does not exist. The default value of 100% means that there is no upper limit on humidity, i.e., there is no humidity control.

The program will not force the cooling coil to perform beyond its dehumidification capability. The program will not be able to hold a specified MAX-HUMIDITY if MIN-SUPPLY-T is not low enough. Figure 41 shows one type of dehumidification cycle. MAX-HUMIDITY causes the simulation to function differently for system types SZRH, PSZ and PVAVS. For SZRH, if the MAX-HUMIDITY level is exceeded, the system reverts to full reheat. The cooling coil leaving air temperature is driven lower and reheat is added at the fan unit to satisfy the control zone. For PSZ and PVAVS systems, specification of MAX-COND-RCVRY will activate the use of condenser recovery to accomplish a similar result. If a lower MAX-HUMIDITY is required to meet desired space conditions, a lower MIN-SUPPLY-T should be entered. For SZRH, PSZ and PVAVS MIN-SUPPLY-T should be entered.

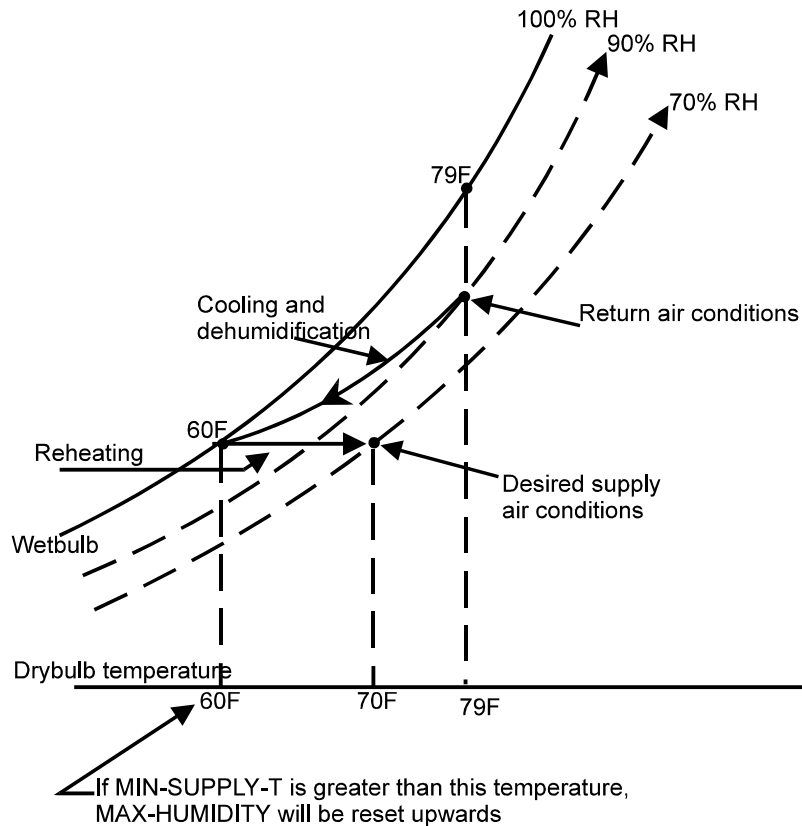

Figure 41 Relationship of MAX-HUMIDITY to MIN-SUPPLY-T

MIN-HUMIDITY

The lowest allowable relative humidity in the return air from zones served by the system. This entry should be used only for those systems that have the components required for minimum humidity control (i.e., humidistat and humidifier). Don't set MIN-HUMIDITY so high that the ductwork condenses the humidity out of the supply air. If no data entry is made, the program will assume that minimum humidity control capability does not exist. The program simulates the use of a humidifier and the required heat for humidification is passed to PLANT as a steam or hot water load.

HUMIDIFIER-TYPE

Accepts a code word specifying the type of humidifier, if any, that is present. The heat of vaporization of the humidification process will be passed on to the appropriate device:

- NONE specifies that no humidifier is available.
- ELECTRIC specifies that the humidifier is electric. The program does not distinguish between the various types of electric humidifiers (pan heaters, electrodes, radiation, etc.)
- HOT-WATER specifies that the humidifier utilizes a pan heat-exchanger supplied by a hot water loop, HW-LOOP
- FURNACE specifies that the humidifier utilizes a gas-fired heat-exchanger. Such a humidifier, if it exists, is unusual.

HUMIDIFIER-LOC

Takes a code-word that specifies the location of the humidifier used to add moisture to the air circulating in the SYSTEM. Humidifiers add moisture up to saturation at the ZONE temperature and allow for better humidity control in VAV and reheat systems, where the supply air temperature may be set by cooling requirements and thus have a low humidity at ZONE temperature. Allowed values for HUMIDIFIER-LOC are:

IN-AIR-HANDLER	The humidity is added in the air handler prior to air being supplied to the ZONES. This means that the humidity in the supply air is limited by the saturation of air at the supply temperature.
IN-SPACE	Each space contains a humidifier controlled by a sensor located in the return air.

Night Cycling of Fans

This set of keywords specifies whether the fans are allowed to restart during unoccupied hours, and the applicable conditions and control

NIGHT-CYCLE-CTRL

Takes a code-word that specifies whether the fans will cycle on at night or on weekends (implied by a 0 in FAN-SCHEDULE) to maintain the temperature setpoint. The fans are off when the hourly values in the schedule that is referenced by FAN-SCHEDULE are equal to 0. If the hourly schedule values are positive, the fans are on and if the hourly schedule values are negative, the fans are not permitted to be on under any circumstances. NIGHT-CYCLE-CTRL also cycles fans on when the temperature goes above the throttling range of the ZONE:COOL-TEMP-SCH. To lock out this feature you must input a -1 in the FAN-SCHEDULE for the summer (cooling) period. NIGHT-CYCLE-CTRL only affects the fan operation. Once the fans have cycled on, the availability of heating or cooling is controlled by HEATING-SCHEDULE and COOLING-SCHEDULE. Allowed values of NIGHT-CYCLE-CTRL are:

STAY-OFF	The fans stay off regardless of conditions.
CYCLE-ON-ANY	The fans are cycled on for the hour if the temperature of any zone in the system falls below the throttling range for heating,
CYCLE-ON-FIRST	The fans are cycled on for the hour if the temperature in the system's control zone falls below the throttling range for heating.
ZONE-FANS-ONLY	For a PIU system, the main or central system PIU fan will remain off but the individual zone terminal fans will cycle on separately to satisfy the heating setback temperature for each zone.

NIGHT-VENT-CTRL

Takes a code-word that specifies the type of night venting (using alternative fans) for cooling the building at night.

NOT-AVAILABLE	When the main fans are scheduled off no other fans can be on.
NIGHT-FAN	When the main fans are scheduled off the night fans always run to provide pressurization (e.g., for a fabric roof system). You can also think of this as the main fans running but at a reduced volume.
NIGHT-FAN+REVERT	When the main fans are scheduled off the night fans run unless any zone falls below its heating throttling range or rises above its cooling throttling range, in which case the main fans are turned on that hour.

WHEN-SCHEDULED When the main fans are scheduled off the night ventilation fans will turn on if NIGHT-VENT-SCH is on and the outside dry-bulb temperature is at least NIGHT-VENT-DT degrees below the temperature in the control zone.

SCHEDULED+DEMAND The same as WHEN-SCHEDULED except that, in addition, at least one conditioned zone in the system must be above the VENT-TEMP-SCH value.

NIGHT-VENT-SCH

Required if NIGHT-VENT-CTRL = WHEN-SCHEDULED or SCHEDULED+DEMAND. Takes the U-name of a schedule (TYPE = ON/OFF) that defines the hours when the night ventilation fans are allowed to run if the main fans are scheduled off. A zero schedule value means the night ventilation fans are not allowed to turn on. A non-zero value means they are allowed to turn on.

NIGHT-VENT-DT

Minimum number of degrees that the outside dry-bulb temperature must be below the temperature of the system's control zone for the night ventilation fans to operate. The value is usually set equal to the temperature rise across the ventilation fans plus a couple of degrees to ensure that a reasonable cooling capacity is available when night venting is used.

NIGHT-VENT-RATIOS

Takes a list of six ratios of night fan parameters to the normal operating fan parameters. The first three are ratios of flow rate, kW per unit flow rate, and fan temperature rise of the night supply fans to the corresponding values (SUPPLY-FLOW, SUPPLY-KW/FLOW and SUPPLY-DELTA-T) for the main supply fans. The last three values define the same three ratios for the night return fans to the main return fans. If no return fans are used during the night operation, the last three values of NIGHT-FAN-RATIOS should be set equal to zero. If the night and main fans are the same and are run in the same way, all six values should be set to 1.0.

NIGHT-CYCLE-FANS

Specifies whether one or both supply fans operate during the period enabled by NIGHT-CYCLE-CONTROL. This keyword only applies to the dual-fan dual-duct system

CYCLE-SEPARATE Starts only the heating fan during off-hours when the building becomes too cold, and starts only the cooling fan when the building becomes too warm.

CYCLE-TOGETHER Always starts both fans during the night cycle periods.

Cooling Equipment

The following keywords specify the capacity and operating characteristics of the equipment in a system. For the simulation to proceed the program must know the details of the operating performance of all equipment. This includes air flow rates, control systems, and design capacity, off-design capacity and energy input requirements. If you are satisfied with the default equipment performance data built into the program, it may not be necessary to specify any keyword values in the SYSTEM command.

COOL-SOURCE

For the PIU system only, takes a code-word that specifies the cooling source for the SYSTEM's main cooling coil. Allowed values of COOL-SOURCE are:

CHILLED-WATER The system uses a chilled-water coil. This option requires that you also specify the CHW-LOOP that supplies this system.

ELEC-DX

The system uses an electric direct-expansion compressor. Both air-cooled and water-cooled CONDENSER-TYPEs are supported. When using this option, you specify the DX performance in a manner identical to packaged-VAV or packaged single-zone systems; using the COOLING-EIR, etc.

If the HEAT-SOURCE = HEAT-PUMP, then the COOL-SOURCE keyword will not be available for user input as it will automatically be set to HEAT-PUMP. Both air-cooled and water-cooled CONDENSER-TYPEs are supported.

If the HEAT-SOURCE = GAS-HEAT-PUMP, then the COOL-SOURCE keyword will not be available for user input as it will automatically be set to GAS-HEAT-PUMP.

COOLING-CAPACITY

Total capacity at ARI rated conditions of either the chilled water cooling coil or the direct expansion cooling system, depending on which has been specified. This keyword overrides the calculated total (sensible + latent) cooling capacity of the system. It is especially useful for packaged units of integral sizes. Note: When specifying COOLING-CAPACITY for packaged DX cooling units with drawthrough fans, SUPPLY-EFF and SUPPLY-STATIC should be omitted and SUPPLY-DELTA-T should be set equal to zero if the COOLING-CAPACITY includes cooling of the fan motor. Otherwise, the supply fan motor heat will be double counted. For better latent simulation SUPPLY-DELTA-T should be specified and COOLING-CAPACITY adjusted to describe the unit without the fan. For DX systems, the program-calculated COOLING-CAPACITY is at ARI rated conditions and fan power and heat are not included. See keyword OUTSIDE-FAN-ELEC.

COOL-SIZING-RAT

Multiplier on the capacity of the cooling coil. Allows you to modify the capacity of the cooling coil without changing the system air flow rates. See SIZING-RATIO, above, which multiplies both coil capacities and air flow rates. If SIZING-RATIO is also specified, the net multiplier on the capacity of the cooling coil is [COOL-SIZING-RAT] x [SIZING-RATIO].

COOL-SH-CAP

Sensible heat removal capacity of the air cooling device at ARI rated conditions (the sensible part of COOLING-CAPACITY). If input, this keyword overrides the calculated sensible cooling capacity of the system. Keyword should be related to the total cooling as most packaged units are $0.8 * (\text{COOLING-CAPACITY})$. At non-ARI rated conditions the value will be corrected by COOL-SH-FT, either by default or by user-supplied data for COOL-SH-FT. Note: The sensible capacity is always less than or equal to the total capacity.

COOL-CAP-FT

Takes the U-name of a bi-linear or bi-quadratic curve that gives the capacity of the cooling coil or cooling system as a function of entering wet-bulb temperature and outside dry-bulb temperature (for direct expansion coils) or entering wet-bulb temperature and entering dry-bulb temperature (for chilled water coils). If the curve is for a Water Loop Heat Pump system (HP), the curve gives the coil cooling capacity as a function of entering wet-bulb temperature and entering water temperature.

COOL-SH-FT

Takes the U-name of a bi-linear or bi-quadratic curve that gives the sensible heat removal capacity of the air cooling device as a function of entering wet-bulb temperature and outdoor dry-bulb temperature for direct expansion units. If the curve is for a Water Loop Heat Pump system (HP), the curve gives the sensible heat removal capacity as a function of entering wet-bulb temperature and entering water temperature. The curve should be normalized so that at rated conditions its value is 1.0 (which means sensible heat removal capacity = COOL-SH-CAP). You should make sure that the data introduced to produce this curve does not result in a sensible heat ratio greater than 1.0.

COIL-BF

This is the cooling coil full load rated bypass factor. This value is used to characterize the performance of a cooling coil. Using the bypass model, the exit air stream from a coil is characterized as being composed of two components: one component leaves the coil at the coil surface temperature and at, or below, the corresponding saturation humidity ratio above or below this saturation value); the other component leaves at the same temperature and humidity ratio as the entering air stream (thus the bypass name). The fraction of the total air flow in the bypassed component is the bypass factor. A graphical representation is shown in Figure 42.

The bypass factor can be calculated by plotting, on the psychrometric chart, the ARI and other entering conditions (A). Then, using the capacity and air flow rate at these conditions, plot the leaving conditions (B). If a line is drawn between these points and extended to the saturation line, it will intersect the saturation line at the coil surface condition (C). You can then calculate the bypass factor for each pair of points. If WE is less than or equal to WL, there is only sensible cooling, and the bypass factor is unused. Thus, the bypass factor and its associated curves should only be produced for conditions when WE > WL.

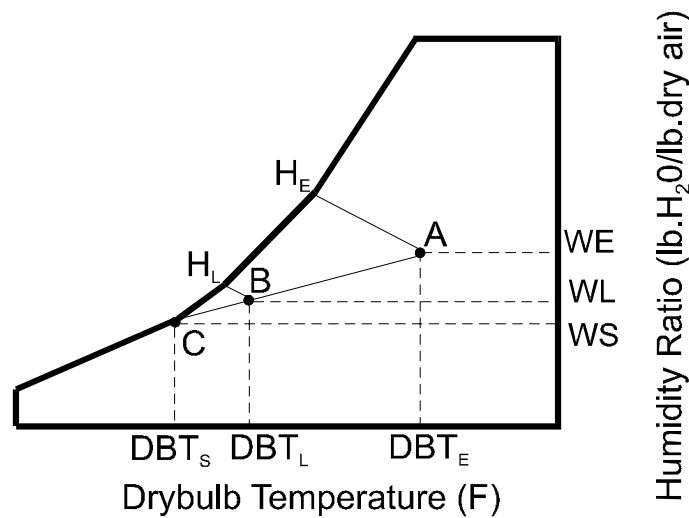

Figure 42 Determining the Coil Bypass Factor

where

- A coil entering condition
- B coil leaving condition
- C coil surface condition
- WE coil entering humidity ratio
- WL coil leaving humidity ratio
- WS coil surface saturation humidity ratio
- HE coil entering enthalpy
- HL coil leaving enthalpy

and

$$\text{BYPASS FACTOR} = \frac{\text{DBT}_s - \text{DBT}_L}{\text{DBT}_s - \text{DBT}_E},$$

$$H_L = H_E - \frac{\text{COOLING-CAPACITY}}{4.5 * \text{CFM}}, \text{ and}$$

$$\text{DBT}_L = \text{DBT}_E - \frac{\text{COOL-SH-CAP}}{1.08 * \text{CFM}}.$$

COIL-BF-FT

Takes the U-name of a bi-linear or bi-quadratic curve that gives the coil bypass factor as a function of the entering wet-bulb temperature and entering dry-bulb temperature. The curve should be normalized so that at rated conditions its value is 1.0.

COIL-BF-FFLOW

Takes the U-name of a linear, quadratic, or cubic curve that gives the coil bypass factor as a function of total supply air flow. The curve should be normalized so that at rated conditions its value is 1.0.

COIL-BF-FPLR

Takes the U-name of a linear, quadratic, or cubic curve that gives the coil bypass factor as a function of part load. This curve applies to PSZ, PVAVS, PMZS, and PVVT DX systems plus all single- and dual-duct air handlers and fan coil units. It describes the part load latent performance of the coil. The coil surface condition is determined by the entering conditions, coil capacity (chilled water setpoints or DX system set as implied through MIN-SUPPLY-T or MIN-SUPPLY-SCH), bypass factor at full load (as found by applying the modifier functions to the ARI point values). As the cooling part load ratio drops the bypass factor is modified by the value of this function in the following way:

$$\text{CBF} = \text{CBFD} + (1.0-\text{CBFD})*(1.0-[\text{COIL-BF-FPLR}])$$

where CBFD is the bypass factor at full load. This means that the part load operation of the coil alters the bypass factor (usually allowing it to rise toward 1.0 at a zero part load ratio). The coil surface temperature, however, is calculated using the full load bypass factor even at part load conditions; thus the amount of air which has water removed is less than at full load (since the part load bypass factor is increasing) but the air that does see the coil responds to the full load surface conditions. COIL-BF-FPLR allows a general specification of the fraction of wet surface as a function of the sensible load on the coil. The intent is to simulate the operation of chilled water or DX coils as the capacity is modulated by reducing the flow through the coil, reducing the coil circuits in use, or other methods of capacity control. The general nature of the curve allows all types of coils to be simulated by adjusting the part load latent performance of the coil by the replacement of this curve. This curve has no direct effect on the total capacity or sensible performance of the system.

Chilled-Water Coils

When the system uses chilled-water for cooling, this set of keywords define the chilled-water coil.

CHW-LOOP

Takes the U-name of the circulation loop to which the central chilled water coil in this system is connected. This keyword also acts as the default for the keyword of the same name in the ZONE command.

CHW-COIL-DT

The temperature change through a chilled water coil at design conditions. This value is used, together with the design load and loop fluid characteristics, to determine the design coil flow. This keyword also acts as the default for the same keyword specified at the zone level. If not specified, the default is the LOOP-DESIGN-DT of the attached loop.

CHW-VALVE-TYPE

Takes a code-word that specifies the type of valve used on the chilled-water coils in this system. Applies to all chilled-water valves whether at the central or zonal level. The value of this keyword also acts as the default for the keyword of the same name in the ZONE command.

TWO-WAY	As the load varies, the valve throttles the flow through the coil and loop to maintain the leaving air temperature. No water is bypassed.
THREE-WAY	As the load varies, some of the flow is bypassed around the coil to maintain the leaving air temperature. The loop flow remains constant.

CHW-COIL-HEAD

The fluid pressure drop through the chilled water coil at the design flow rate. This value should include the friction losses of the coil's control valve, trim, and any piping associated with the coil and not included in the pressure drop of the loop that serves this coil. This keyword also acts as the default for the keyword of the same name in the ZONE command.

CHW-CAP-FEWBEWT

For chilled water systems, takes the U-name of a bi-linear or bi-quadratic curve that defines how the coil capacity varies with the entering wet-bulb temperature and the entering water temperature. This curve should give a value of 1.0 at 65F temperature.

CHW-CAP-FFLOW

For chilled water systems, takes the U-name of a linear or quadratic curve that gives the coil capacity as a function of water flow rate.

HCOIL-WIPE-FFLOW

For a single-fan dual-duct or multizone system, takes the U-name of a linear or quadratic curve that gives the fraction of the that first passes over the heating coil before entering the cooling coil. This curve is a function of the fraction of total airflow that passes over the hot deck is assumed to enter the cold deck at the hot deck temperature. This keyword does not apply to dual-fan dual-duct systems, as the hot and cold deck airflow paths are completely separate.

DX Cooling

For systems using direct-expansion cooling, this set of keywords defines the parameters of the compressor and condenser.

COOLING-EIR

The Electric Input Ratio (EIR), or $1/(\text{Coefficient of Performance})$, for the cooling unit at ARI rated conditions. The program defines EIR to be the ratio of the electric energy input to the rated capacity, when both the energy input and rated capacity are expressed in the same units. This EIR is at ARI rated conditions, i.e., without correction for different temperature or part load.

Note: If you include fan electric energy consumption in your value of COOLING-EIR, then you should set SUPPLY-KW/FLOW to zero (and SUPPLY-STATIC, SUPPLY-EFF and SUPPLY-DELTA-T should be omitted). Otherwise, the supply fan electrical energy will be double counted. For commercial systems the default value of COOLING-EIR includes compressor and outdoor fan energy, but not indoor fan energy.

COOL-EIR-FT

Takes the U-name of a bi-linear or bi-quadratic curve that describes the Electric Input Ratio for cooling as a function of entering wet-bulb temperature and outdoor dry-bulb temperature (for direct expansion coils) or entering wet-bulb temperature and entering water temperature for a Water Loop Heat Pump (HP) system. At ARI conditions, the value of the curve should be 1.

COOL-EIR-FPLR

Takes the U-name of a linear, quadratic or cubic curve that gives the EIR for cooling as a function of part load ratio (PLR). This keyword is unused with chilled water coils. The curve should be normalized so that at ARI conditions its value is 1. See keyword MIN-HGB-RATIO.

COOL-FT-MIN

Minimum outside dry-bulb cut-off temperature for the curves referenced by COOL-CAP-FT, COOL-EIR-FT, and COOL-SH-FT. This is the minimum extrapolation point. As the outside dry-bulb temperature (one of the two independent variables in each of the three curves) drops below this point the accuracy of the three curves is degraded. The program assumes that the second dependent variable in each of the three curves remains constant at all outside dry-bulb temperatures below COOL-FT-MIN. The program assumes that the corresponding cut-off wet-bulb temperature is 60F (15.6C).

COMPRESSOR-TYPE

Takes a code-word that specifies the compressor speed control mechanism; this keyword is intended for use in modeling a packaged direct expansion heat pump or air-conditioning that incorporated variable speed compressor control: It is suggested that the SYSTEM:AIR/TEMP-CONTROL keyword be used for systems which incorporate multiple steps or stages of capacity rather than this keyword/codeword combination.

SINGLE-SPEED	specifies that the compressor operates at a constant speed, and modulates its capacity by cycling on/off. This is the default for most system types.
DUAL-SPEED	specifies that the compressor has two stages of capacity. This is appropriate for the residential system (for RESYS, RESYS2 only). It is suggested that the SYSTEM:AIR/TEMP-CONTROL be used for staged capacity systems rather than this keyword/codeword combination.
VARIABLE-SPEED	specifies that the compressor can vary its speed to exactly match the capacity required. This is applicable to RESVVT, PSZ, PVAVS and PVVT systems.

MIN-UNLOAD-RATIO

The point, expressed as a part load ratio (PLR), at which compressor unloading stops and hot gas bypass or cycling begins. The COOL-EIR-FPLR applies in the range of PLR between MIN-UNLOAD-RATIO and 1.0. See MIN-HGB-RATIO.

MIN-HGB-RATIO

Part load ratio where hot gas bypass ends and the compressor starts a cycling mode. MIN-HGB-RATIO is always equal to or less than MIN-UNLOAD-RATIO. Note that the default MIN-HGB-RATIO for system types PVAVS, PMZS, and PVVT is at 0.0 load, while MIN-UNLOAD-RATIO defaults to 0.25 for these systems. This is to allow a default simulation of compressors that have been equipped with hot gas bypass or a similar feature that allows the compressor to continue to run, rather than cycle, at low loading points. This simulation causes the compressor power to be held at PLR = 0.25 on the COOL-EIR-FPLR curve for all hours that the load on the unit is less than 25% of the operating capacity. This is done in situations where stable space temperature control is desired. The values of MIN-UNLOAD-RATIO and MIN-HGB-RATIO should be adjusted to agree with the arrangement of equipment in the building.

CRANKCASE-HEAT

Electric power used to heat the crankcase of direct expansion (DX) and heat pump compressors. The crankcase heater is assumed to be on only when the compressor is off. Crankcase electric power is allocated to the AUX-ELEC-METER.

CRANKCASE-MAX-T

Outside temperature above which the crankcase heater is off. Otherwise, the heater is off whenever cooling is available (see COOLING-SCHEDULE).

CONDENSER-TYPE

Takes a code-word that specifies the type of condenser in packaged systems with direct-expansion cooling (and optional heating.) Note that the program changes the default performance data (such as EIR) when you change the condenser type; if the unit being modeled is atypical input data representative of the unit should be used to replace the default performance parameters.

AIR-COOLED	The condenser is air cooled.
WATER-COOLED	The condenser is water cooled. You must attach the condenser to a CIRCULATION-LOOP of TYPE = CW or WLHP via the CW-LOOP keyword. For PSZ, PVAVS and PVVT, use of this value indicates that a water-to-air heat pump (WLHP) is to be modeled.
EVAP-PRECOOLED	The air-cooled condenser on a RESYS2, PSZ, PMZS, PVAVS, PTAC, or PVVT system includes an evaporative pre-cooler. The pre-cooler is controlled by a time and/or temperature controller that decides if the unit should operate (see EVAP-PCC-SCH, EVAP-PCC-EFF, and EVAP-PCC-ELEC). When this unit doesn't operate, the condenser returns to CONDENSER-TYPE = AIR-COOLED. The evaporative pre-cooler is only active during cooling mode. If no operation schedule is specified using EVAP-PCC-SCH, a default operation is assumed that provides for cooling mode operation whenever the outside dry-bulb temperature is more than 2F (1.1K) above the value of COOL-FT-MIN.

MAX-COND-RCVRY

For DX air conditioners, this is the fraction of the design condenser capacity that is recoverable for space heating. May be used for reheat when supply temperature is lowered in response to a humidity controller.

OUTSIDE-FAN-MODE

Takes a code-word that specifies whether the outside fan operates continuously (CONTINUOUS) or only when the compressor is on (INTERMITTENT). This keyword is appropriate only to RESYS2, PSZ, PMZS, and PVAVS.

OUTSIDE-FAN-ELEC

The electric power of the condenser fan (or unit) divided by the cooling system capacity at ARI conditions.

OUTSIDE-FAN-T

Outside temperature below which the condenser fan is not permitted to operate.

OUTSIDE-FAN-CFLT

Takes the U-name of a quadratic curve that modifies the outdoor fan power during cooling as a function of the cooling part load ratio and the condenser entering temperature (either outside dry-bulb or evaporative pre-cooler exit temperature). This allows the simulation of multi-speed or multi-fan condensing units.

EVAP-PCC-EFF

The effectiveness of the evaporative process in an evaporative precooling unit. Equals the fraction of the maximum wet-bulb depression that can be realized by the outdoor air passing through the precooling unit before entering the condensing section. In any case, the approach to the wet-bulb temperature is not allowed to become smaller than 3F (1.7K) when the precooling unit is operating.

EVAP-PCC-ELEC

Gives the electric power consumption of the evaporative precooling unit divided by the cooling system output capacity at ARI conditions.

EVAP-PCC-SCH

Takes the U-name of a SCHEDULE that controls when the evaporatively precooled condenser for air cooled units can operate. A zero schedule value indicates that the unit is locked off. A value of 1 indicates the unit is operating. A value >1 indicates that the unit operates only if the outside temperature is less than the scheduled value. A value <0 indicates that the unit operates only if the outside temperature is greater than the absolute value of the schedule value (for example, for INPUT-UNITS = ENGLISH, a schedule value of -40 means that the unit operates only if the outside temperature is above 40F).

Water-Cooled Condensers

When CONDENSER-TYPE = WATER-COOLED, these keywords describe the parameters of the water-cooled condenser.

CW-LOOP

For a water-loop heat pump or a water-cooled DX unit, takes the U-name of the CIRCULATION-LOOP to which the condenser is attached. For a water-cooled DX unit the loop can be of type CW or WLHP. In other words, a water-cooled condenser of a DX unit may be connected to a condenser loop or to a water-loop heat pump loop. A WLHP unit can only be connected to a loop of type WLHP. This keyword also acts as the default for the keyword of the same name in the ZONE command.

CW-COIL-DT

The temperature drop through the condenser water coil at design conditions. This value is used, together with the design load and loop fluid characteristics, to determine the design coil flow through the condenser. The default is the CIRCULATION-LOOP:LOOP-DESIGN-DT value of the loop to which the coil is attached. This keyword also acts as the default for the keyword of the same name in the ZONE command.

CW-VALVE

Takes a code-word that specifies whether a water-loop heat pump or water-cooled DX condenser has a valve that cycles open and closed as the compressor cycles on and off. This keyword also acts as the default for the keyword of the same name in the ZONE command.

NO	The unit does not have an isolation valve. Full flow occurs whenever the loop pump is active.
YES	The unit has an isolation valve that shuts off loop flow through the unit when the unit's compressor is off.

CW-COIL-HEAD

Accepts a numeric value that specifies the pressure drop through the condenser of the loop fluid at the design flowrate. This value should include the friction losses of the coil's control valve, trim, and any piping associated with the coil and not included in the pressure drop of the loop which serves this coil.

This keyword also acts as the default for the same keyword which can be specified as the zonal level.

Waterside Economizers

The next set of keywords specifies the operation of a water-side economizer, if present. A water-side economizer consists of a coil attached to a condenser-water loop. The coil operates whenever a cooling load exists, and the outdoor conditions can produce condenser water colder than the mixed-air temperature.

The water-side economizer coil is assumed to be downstream of the mixed air plenum, and upstream of the cooling coil. As such, the cooling coil may supplement the operation of the water-side economizer. The air handler may also have a conventional outdoor-air economizer, in which case the outdoor-air economizer will operate first to meet the supply-air setpoint, then the water-side economizer will supplement the outdoor-air economizer, and the cooling coil will pick up the remaining load, if any.

Water-side economizers are commonly used when a more conventional outdoor-air economizer is not practical. Examples include high-rise buildings without sufficient duct access to the outdoors, and water-loop heat pumps. While some people believe that a water-side economizer can be more energy efficient than an outdoor-air economizer, this is seldom the case for several reasons:

A water-side economizer coil increases the pressure drop on the supply fan, which results in a significant increase in annual fan energy. Coupled with the increased energy of the cooling tower and condenser water pump, these energy penalties may be considerably larger than the chiller savings.

Chiller savings will not normally accrue if an outdoor-air economizer can be used instead of a water-side economizer. While it is always true that the outdoor wetbulb is lower than the outdoor drybulb, there is a temperature differential in the cooling tower between the wetbulb and leaving water temperature, and another differential in the economizer coil between the condenser water temperature and the leaving air temperature. To overcome these differentials, the outdoor wetbulb temperature must be 15-20F lower than the outdoor drybulb temperature to produce the same effect as an outdoor-air economizer. Compared to an outdoor air economizer operating at 60F, a water-side economizer must have a wetbulb in the range of 40-45°F, which

WS-ECONO

Takes code-words NO and YES to indicate if a water-side economizer will be simulated. It is not necessary that the condenser be water cooled, although this is usually the case.

WS-ECONO-MIN-DT

The temperature difference between the condenser water loop supply temperature and the mixed-air temperature must be greater than this value for the water-side economizer to be activated.

WS-ECONO-XEFF

The coil design effectiveness for the economizer coil, between the condenser water loop and the mixed-air temperature.

WS-ECONO-KW/FLOW

Specifies the additional fan power per unit flow required to overcome the air pressure drop through the economizer coil. The total fan power per unit flow when using a water-side economizer is [SUPPLY-KW/FLOW] + [WS-ECONO-KW/FLOW]. If SUPPLY-KW/FLOW (and SUPPLY-DELTA-T) already take the static pressure of the economizer coil into account, then WS-ECONO-KW/FLOW should be set to zero. It is very important to account for the change in fan power associated with a water-side economizer since it can have a significant effect on the overall energy efficiency and cost effectiveness of this device.

WS-ECONO-FAN-DT

Specifies the additional fan temperature rise required to overcome the air pressure drop through the economizer coil. The total air temperature rise through the fan when using a water-side economizer is [SUPPLY-DELTA-T] + [WS-ECONO-FAN-DT]. If SUPPLY-DELTA-T already takes the static pressure of the economizer coil into account, then WS-ECONO-FAN-DT should be set to zero.

WSE-LOOP

Takes the U-name of the CIRCULATION-LOOP to which the water-side economizer coil is attached. The economizer will normally be attached to the same loop as the condenser, although they may be attached to different loops. Acceptable loop types are CW and WLHP.

WSE-COIL-DT

The temperature change of the condenser water through the water-side economizer coil at design conditions. This value is used, together with the design load and loop fluid characteristics, to determine the design coil flow. If not specified, the default is the LOOP-DESIGN-DT of the attached loop.

WSE-VALVE-TYPE

Takes a code-word that specifies the type of valve this coil has.

TWO-WAY	As the load varies, the valve throttles the flow through the coil and loop to maintain the leaving air temperature. No water is bypassed.
THREE-WAY	As the load varies, some of the flow is bypassed around the coil to maintain the leaving air temperature. The loop flow remains constant.

WSE-COIL-HEAD

The condenser water pressure drop through the water-side economizer coil at the design flow rate. This value should include the friction losses of the coil's control valve, trim, and any piping associated with the coil and not included in the pressure drop of the loop that serves this coil. The value should be based on the head loss of pure water. This keyword also acts as the default for the keyword of the same name in the ZONE command.

Add-On Desiccant Cooling

The following keywords apply to add-on desiccant cooling units that are integrated with conventional systems that have mechanical cooling components. These add-on units can be integrated with the following system types: SZRH, PSZ, SZCI, RHFS, VAVS, PIU, PVAVS, PVVT, CBVAV, MZS, PMZS, DDS and IU.

DESICCANT

Takes a code-word that specifies the type of desiccant unit. Allowed values are:

NO-DESICCANT	No desiccant unit is present.
LIQ-VENT-AIR-1	A liquid desiccant dehumidifying unit called a "humidity pump" (Figure 43). See DESC-CTRL-MODE for control modes. See DESC-DEW-SET for the dewpoint temperature setpoint of the air leaving the unit.

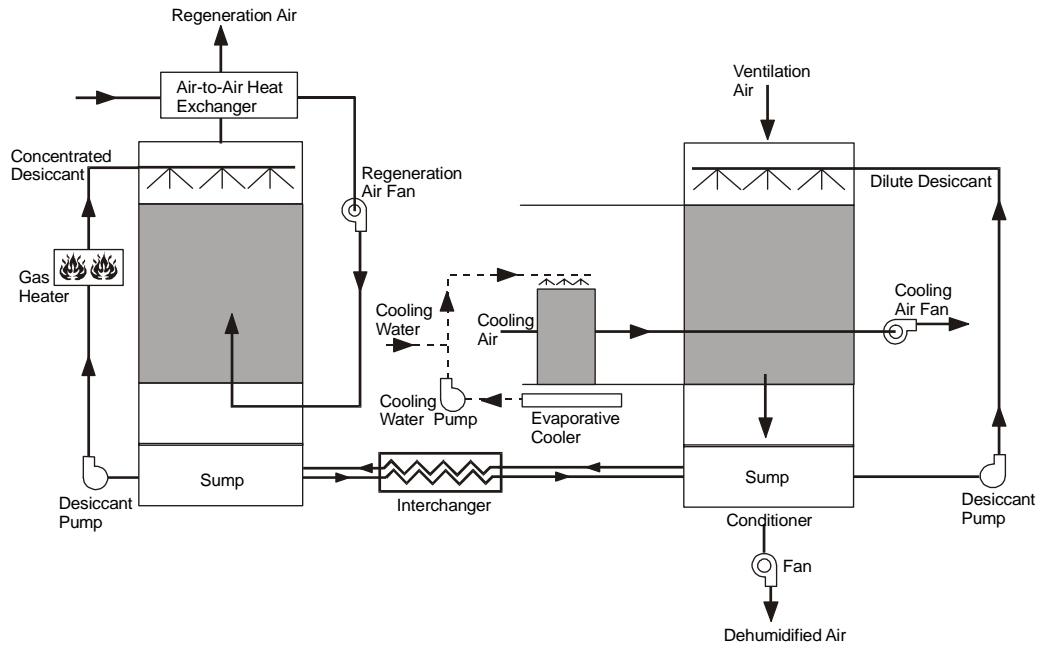

Figure 43 Humidity pump (LIQ-VENT-AIR-1)

SOL-VENT-AIR-1

The solid desiccant dehumidifying unit (Figure 45 to Figure 48). See DESC-CTRL-MODE for control modes. See HEAT-EXCH-EFF and HEAT-EXCH-DELP for characteristics of the sensible heat-exchanger.

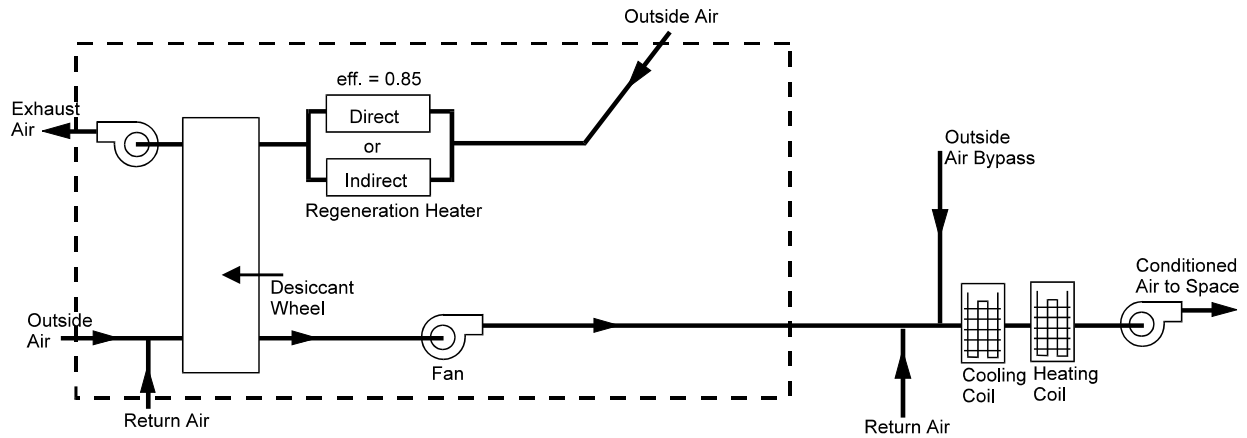

Figure 45 Solid desiccant unit with dehumidifier only, shown integrated with a sensible cooling system (SOL-VENT-AIR-1 and DESC-CTRL-MODE = 0)

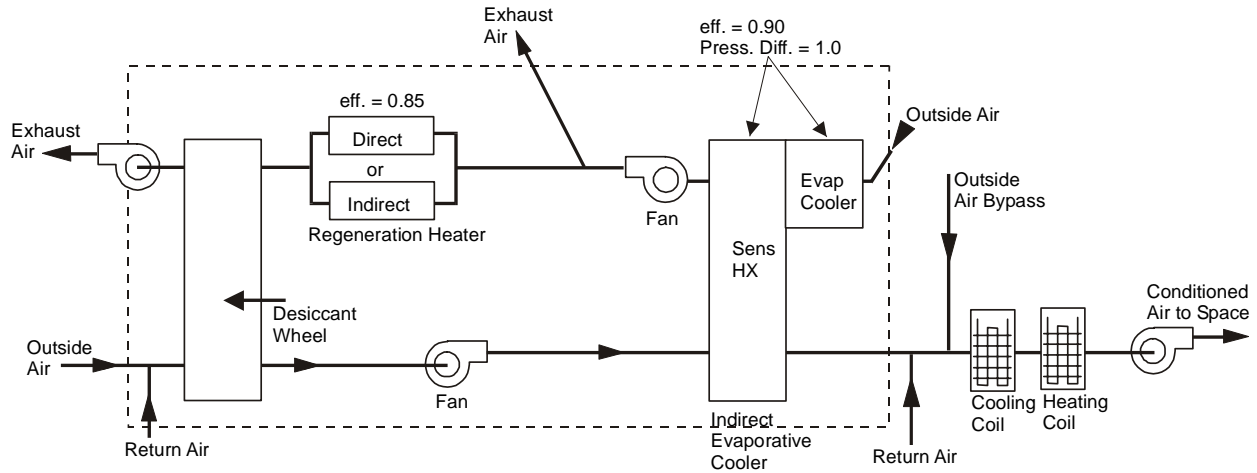

Figure 46 Solid desiccant unit with dehumidifier and heat-exchanger with regeneration preheat, shown integrated with a sensible cooling system (SOL-VENT-AIR-1 and DESC-CTRL-MODE = 1)

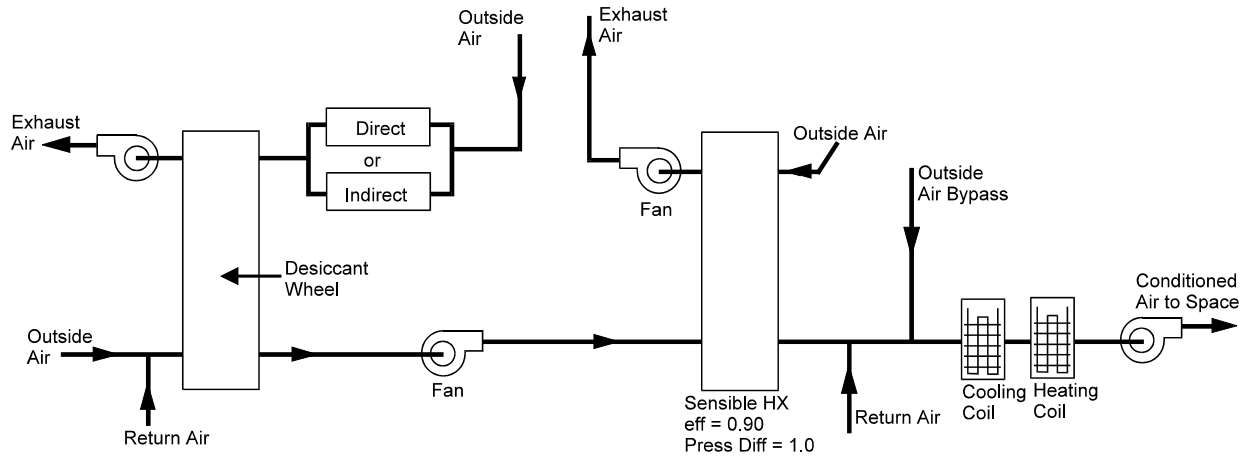

Figure 47 Solid desiccant unit with dehumidifier and heat-exchanger without regeneration preheat, shown integrated with a sensible cooling system (SOL-VENT-AIR-1 and DESC-CTRL-MODE = 2)

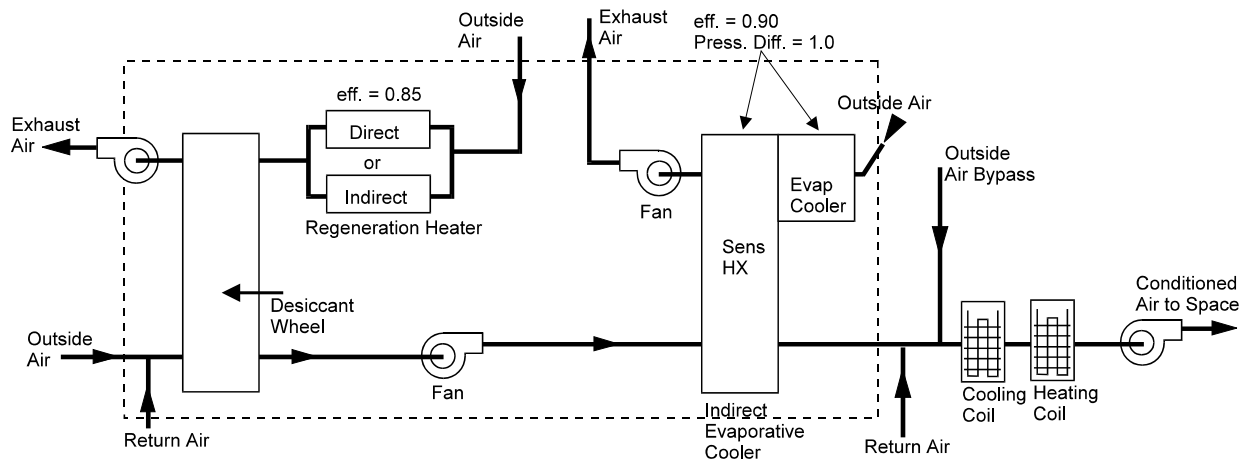

Figure 48 Solid desiccant unit with dehumidifier and indirect evaporative cooler, without regeneration preheat, shown integrated with a sensible cooling system (SOL-VENT-AIR-1 and DESC-CTRL-MODE = 3)

DESC-CTRL-MODE

For liquid desiccant units (SYSTEM:DESICCANT = LIQ-VENT-AIR-1 or LIQ-VENT-AIR-2) takes an integer value that determines the desiccant unit control mode:

Liquid desiccant unit that operates whenever the outside air temperature is above DRY-BULB-LIMIT and the system fan is on.

Liquid desiccant unit that cycles on a direct evaporative cooling unit to maintain the exit dewpoint, DESC-DEW-SET. The rationale for this is that when the air exiting the desiccant unit is overly dry, the evaporative cooler can provide additional sensible cooling and add moisture back into the air. Not allowed for LIQ-VENT-AIR-2.

Cycles the desiccant unit itself on and off to maintain the exit dewpoint, DESC DEW SET. Not allowed for LIQ-VENT-AIR-2.

For solid desiccant units (SYSTEM:DESICCANT = SOL-VENT-AIR-1) takes an integer values that determines the configuration of the unit.

Solid desiccant unit with dehumidifier only.

Solid desiccant unit with dehumidifier and heat-exchanger, with regeneration preheat.

Solid desiccant unit with dehumidifier and heat-exchanger, without regeneration preheat.

Same as SOL-VENT-AIR-1 = 2, but the heat-exchanger is replaced by an indirect evaporative cooler.

DESC-DEW-SET

The exit dewpoint control temperature for liquid desiccant units

DESICCANT-AIR

The air flow rate through the desiccant unit, entered as a fraction of the design supply air flow rate of the HVAC system. Used to size the desiccant unit, which is related to the size of the HVAC system with which it is integrated. If DESICCANT-AIR is equal to the minimum outside air ratio, only outside air flows through the unit. This is the default when DESICCANT-AIR is not input. If DESICCANT-AIR exceeds the minimum outside air ratio, the inlet air stream of the desiccant unit is a mixture of outside air and return air. Usually, DESICCANT-AIR is set equal to MIN-OUTSIDE-AIR or to 1.0 (that latter providing a 100% outside air system). However, if SYSTEM:OA-CONTROL = FIXED, the unit operates at 100% outside air only when the unit is on and returns to minimum outside air when the unit is off.

DESC-HEAT-SOURCE

Takes a code-word that defines the source of the heat that regenerates the desiccant and provides space heating. This keyword was previously REG-HEAT-SOURCE. Allowed values are:

HOT-WATER	The CIRCULATION-LOOP to which the unit is attached provides the heat.
GAS-HYDRONIC	A small, gas-fired boiler packaged as part of the desiccant unit provides the heat. The gas will be provided by the meter specified for the cooling end-uses of this system.
GAS-CHILLER	A gas-fired chiller/heater provides the heat. This is the common configuration for the LIQ-VENT-AIR-2 unit. The U-name of the chiller/heater is given by DESC-CHILLER. The CHILLER:GAS-DESC-XEFF, GAS-HIR-FDESCT and GAS-QREG-FDESCT keywords also apply.

HEAT-EXCH-DELP

The pressure drop of the supply air stream across the sensible heat-exchanger in the solid desiccant unit (DESICCANT = SOL-VENT-AIR-1). This value is used to calculate the additional fan energy for this unit. Applies only to DESC-CTRL-MODE = 1 and 2 (integrated desiccant cooling system); Figure 46, Figure 47

HEAT-EXCH-EFF

The effectiveness of the sensible heat-exchanger in the solid desiccant unit (DESICCANT = SOL-VENT-AIR-1) when DESC-CTRL-MODE = 1 and 2; Figure 46, Figure 47.

Heating Equipment

HEATING-CAPACITY

Heating capacity of the system, entered as a negative value. If not input, it will be calculated by the program.

The heating capacity of a heat pump is related to its cooling capacity. If a heat pump is sized by the program, its compressor capacity is determined by the larger of the heating and cooling requirements as follows:

$$\text{Compressor capacity} = \max [\text{required cooling capacity} * \text{heating COP} / \text{cooling COP} \\ \text{required heating capacity} * \text{cooling COP} / \text{heating COP}].$$

The program does not round up or round down the calculated capacity to correspond to the integral sizes that are available for packaged units. If desired, you can do this manually after the calculated value is known.

HEAT-SIZING-RAT

Multiplier on the capacity of the heating coil. Allows you to modify the capacity of the heating coil without changing the system air flow rates. See SIZING-RATIO, above, which multiplies both coil capacities and air flow rates. If SIZING-RATIO is also specified, the net multiplier on the capacity of the heating coil is [HEAT-SIZING-RAT] x [SIZING-RATIO].

HEAT-SOURCE

Takes a code-word that specifies the heat source for the SYSTEM's main heating coils. This keyword can also be used for the UHT, UVT, FC and PTAC zone heating coils since these coils are served by a central distribution system. Allowed values of HEAT-SOURCE are:

NONE	No heating is allowed.
ELECTRIC	The heat source is an electric resistance element.
HOT-WATER	The heat source is hot water provided by a CIRCULATION-LOOP.
FURNACE	The heat source is a furnace.
HEAT-PUMP	The source of heat is an electric air-to-air heat pump. Used only for the RESYS, PSZ, PTAC, PVVT, PVAVS, PIU, RESYS-VVT, and RESYS2 systems. For PSZ, PVVT, PVAVS and PIU, when used in conjunction with CONDENSER-TYPE of WATER-COOLED, a water-to-air heat pump is modeled. If the system is a PIU system, and you specify HEAT-SOURCE = HEAT-PUMP, then the COOL-SOURCE will not be available as it will automatically be set to HEAT-PUMP.
GAS-HEAT-PUMP	The heat source is a natural-gas engine-driven heat pump. Used only with the PSZ, PVVT, PTAC, RESYS, PVAVS, and PIU system types. If the system is a PIU system, and you specify HEAT-SOURCE = GAS-HEAT-PUMP, then the COOL-SOURCE will not be available as it will automatically be set to GAS-HEAT-PUMP.
GAS-HYDRONIC	For the PTGSD system type, specifies that the heat source is a gas-fired hot water generator..

DHW-LOOP The heat source is hot water provided by a CIRCULATION-LOOP of TYPE = DHW (domestic hot water). Residential buildings in mild climates sometimes use the domestic water heater to also provide space heat.

ZONE-HEAT-SOURCE

Takes a code-word that specifies the heat source for the zone heating coils (reheat coils) in central air handler systems. Allowed values are:

NONE	No heating is allowed.
ELECTRIC	The heat source is an electric resistance element.
HOT-WATER	The source of heat is hot water provided a CIRCULATION-LOOP.
FURNACE	The heat source is a furnace.
HEAT-PUMP	The source of heat is an electric air-to-air heat pump. Used only for the RESYS, RESYS2, PSZ PVAVS, PTAC, RESVVT, and PVVT systems. Note that if COMPRESSOR-TYPE = VARIABLE-SPEED, then the compressor is assumed to be variable speed.
GAS-HEAT-PUMP	The heat source is a natural-gas engine-driven heat pump. Used only with the PSZ, PVVT, PTAC, RESYS and PVAVS system types.
GAS-HYDRONIC	For the PTGSD system type, specifies that the heat source is a gas-fired hot water generator. For the RESYS system type, specifies that a domestic hot water heater provides hot water to the heating coil.
DHW-LOOP	The heat source is hot water provided by a CIRCULATION-LOOP of TYPE = DHW (domestic hot water). Residential buildings in mild climates sometimes use the domestic water heater to also provide space heat.

Hot-Water Coils

when HEAT-SOURCE = HOT-WATER, these keywords describe the characteristics of the hot-water coils.

HW-LOOP

when HEAT-SOURCE = HOT-WATER, accepts the U-name of the loop to which the central hot water coil in this system is connected. Acceptable loop types are HW and PIPE-2. This keyword also acts as the default for the same keyword that can be specified at the zonal level.

When sizing the coil, the program checks to see if the coil's leaving air temperature is consistent with the fluid temperature supplied from the circulation loop. The fluid temperature entering the coil must be at least 10F (5.6K) warmer than the leaving air temperature, or the program will generate an error. This is true for all of the heating coils (heating, preheat, reheat, etc.)

HW-COIL-DT

The temperature change through a hot water coil at design conditions. This value is used, together with the design load and loop fluid characteristics, to determine the design coil flow. This keyword also acts as the default for the keyword of the same name in the ZONE command. If not specified, the default is the CIRCULATION-LOOP:LOOP-DESIGN-DT value of the loop to which the coil is attached. HW-COIL-DT applies to all hot water coils in the system including central heating, preheat, reheat, zonal, and baseboard.

HW-VALVE-TYPE

Takes a code-word that specifies the type of valve used on hot water coils in the system. Applies to all hot water valves in the system, including main heating coil, preheat, reheat, zonal, and baseboards. Different systems may have different types of valves. This keyword also acts as the default for the keyword of the same name in the ZONE command.

TWO-WAY As the load varies, the valve throttles the flow through the coil and loop to maintain the leaving air temperature. No water is bypassed.

THREE-WAY As the load varies, some of the flow is bypassed around the coil to maintain the leaving air temperature. The loop flow remains constant.

HW-COIL-HEAD

The fluid pressure drop through the hot water coil at the design flow rate. This value should include the friction losses of the coil's control valve, trim, and any piping associated with the coil and not included in the pressure drop of the loop that serves this coil. This keyword also acts as the default for the keyword of the same name in the ZONE command.

DHW-LOOP

When HEAT-SOURCE = DHW-LOOP, accepts the U-name of the domestic hot water loop that provides heat energy to this heating coil. Sometimes apartments or homes in mild climates do not require significant heating. It is sometimes more economical to increase the size of the domestic water heater, and use it for space heating as well as domestic hot water.

ZONE-HW-LOOP

Takes the U-name of the hot-water CIRCULATION-LOOP that a zone's heating coils will use if HW-LOOP is not specified in the ZONE command. Defaults to the U-name of the system-level HW-LOOP.

This keyword is for input convenience only. It allows the central heating coil of a system to be attached to one loop and all of the zonal heating coils to be on a different loop without having to specify the zonal HW-LOOP for each zone.

HW-CAP-FDT

Takes the U-name of a linear or quadratic curve that gives the hot water coil capacity as a function of the temperature difference between the entering air temperature and the entering water temperature. The curve is normalized to 1.0 at the design conditions.

HW-CAP-FFLOW

Takes the U-name of a linear or quadratic curve that gives the hot water coil capacity as a function of flow.

Gas/Oil Furnaces

When HEAT-SOURCE = FURNACE, these keywords describe the operating characteristics of the gas-fired or oil-fired furnace

FURNACE-HIR

Ratio of fuel used by the furnace (including that used by the pilot light, if present) to the heating energy produced. In calculating this ratio, the fuel used and heating produced should be expressed in the same units.

FURNACE-HIR-FPLR

Takes the U-name of a linear, quadratic or cubic curve that defines a multiplier on FURNACE-HIR as a function part-load ratio. The curve should be normalized so that at full load its value is 1.0.

FURNACE-AUX

The rate of energy use of the furnace pilot. For a gas-fired furnace, this is the energy consumed by the pilot light when there is no load on the furnace. In this case the program assumes that the pilot light consumption when the furnace is "on" is included in FURNACE-HIR-FPLR. For an oil-fired furnace, FURNACE-AUX is the energy consumed by the spark ignition and the fuel pumping system when there is a load on the furnace. In this case, the auxiliary energy consumed in a given hour is FURNACE-AUX times the part load ratio that hour (therefore, no energy is consumed when there is no load on the furnace). This auxiliary fuel is allocated to the AUX-FUEL-METER.

FURNACE-AUX-KW

Furnace electrical auxiliary power during furnace run time. Applicable to all types of furnaces including the gas heat pump supplemental furnace. The default is 0.0 except for the gas heat pump, in which case the default is 0.1 kW. The auxiliary electric power is allocated to the AUX-ELEC-METER.

FURNACE-OFF-LOSS

Takes the U-name of a linear, quadratic or cubic curve that gives the fraction of the unused furnace capacity that is an induced load as a function of outdoor dry-bulb temperature. The unused furnace capacity (HEATING-CAPACITY minus the furnace load, assuming no loss) is multiplied by this function and the result is added to the furnace load. The loss is added only when the furnace is operating. This loss is usually caused by infiltration induced by a non-outside-air supplied burner or off-cycle furnace cooling. There is no default curve.

Air-to-Air Heat Pumps

When HEAT-SOURCE = HEAT-PUMP or GAS-HEAT-PUMP, these keywords define the operating characteristics of the heat pump unit. These keywords apply primarily to heating operation; see *DX Cooling* for keywords that apply to the cooling mode.

HEAT-CAP-FT

Takes the U-name of a bi-linear or bi-quadratic curve that gives the heat pump heating capacity as a function of outdoor dry-bulb temperature and entering dry-bulb temperature. The curve should be normalized so that at rated conditions its value is 1.0.

HEAT-CAP-FRPM

For SYSTEM:HEAT-SOURCE = GAS-HEAT-PUMP and for HEAT-SOURCE = HEAT-PUMP with COMPRESSOR-TYPE = VARIABLE-SPEED, takes the U-name of a quadratic curve that gives the variation in the unit heating capacity as a function of the motor RPM. At maximum RPM the curve should be normalized to 1.0. This curve is inverted by the program to obtain the RPM when the unit heating load is given.

HEATING-EIR

Electric Input Ratio, or 1/(heating Coefficient of Performance), for the heat pump. This EIR is at ARI rated conditions, i.e., without corrections for temperature or part load. The program-calculated HEATING-EIR does not include fan power and heat. This keyword is appropriate only to HP, RESYS, and PTAC systems.

HEAT-EIR-FT

Takes the U-name of a bi-linear or bi-quadratic curve that describes the Electric Input Ratio for heating (heat pumps) as a function of entering dry-bulb temperature and outdoor dry-bulb temperature. At ARI conditions, the value of the curve should be 1.

HEAT-EIR-FPLR

Takes the U-name of a linear, quadratic, or cubic curve that gives the heat pump EIR for heating as a function of part load ratio (PLR). The curve should be normalized so that at rated conditions its value is 1.0.

HEAT-EIR-FRPM

For SYSTEM:HEAT-SOURCE = GAS-HEAT-PUMP and for HEAT-SOURCE = HEAT-PUMP with COMPRESSOR-TYPE = VARIABLE-SPEED, takes the U-name of a curve that gives the variation in the unit EIR during heating as a function of motor RPM. The curve is normalized to 1.0 at maximum heating RPM. It is used to obtain the part load power consumption of the unit. For variable speed heat pumps it replaces HEAT-EIR-FPLR, which is used for constant speed units.

HEAT-EIR-LS-FT

For HEAT-SOURCE = GAS-HEAT-PUMP, COMPRESSOR-TYPE = VARIABLE-SPEED, takes the U-name of a curve that describes the variation in the EIR for heating at minimum RPM as a function of entering wet-bulb temperature and outside dry-bulb temperature. The program interpolates between this curve and HEAT-EIR-FT to obtain the entering wet-bulb - outside dry-bulb correction factor for RPM's between minimum and maximum. This curve is normalized to 1.0 at the ARI rating point.

HP-SUPP-SOURCE

Takes a code-word that specifies the type of supplemental heating for a heat pump. GAS-HYDRONIC and FURNACE are valid for gas heat pump systems only.

ELECTRIC	The supplemental heat source is an electric resistance heater. This power is allocated to the SUPP-ELEC-METER.
GAS-HYDRONIC	The supplemental heat source is a gas-fueled hydronic boiler. This type of equipment requires the circulation pump (UNIT-PUMP-ELEC) to operate if the supplemental unit is on but the gas heat pump is off. For GAS-HYDRONIC other applicable keywords are FURNACE-HIR, FURNACE-AUX, FURNACE-AUX-KW, and UNIT-PUMP-ELEC.
HOT-WATER	The supplemental heat source is hot water. Requires that a CIRCULATION-LOOP of TYPE = HW be attached via the HW-LOOP keyword.
FURNACE	The supplemental heat source is a gas-fueled furnace. In this case other applicable keywords are FURNACE-HIR, FURNACE-AUX and FURNACE-AUX-KW. Fuel consumed is allocated to the SUPP-FUEL-METER.

HP-SUPP-HT-CAP

Supplemental heating capacity for a heat pump, expressed as a negative number. The program will size this to the maximum heating load since this usually occurs when the heat pump is unavailable

MIN-HP-T

Outdoor dry-bulb temperature below which the heat pump turns off

MAX-HP-SUPP-T

Outside dry-bulb temperature below which the heat pump supplemental heating is allowed to operate.

DEFROST-TYPE

Takes a code-word that specifies the type of defrost cycle on the heat pump.

REVERSE-CYCLE	The heat pump action is reversed to provide heat to melt frost.
RESISTIVE	The frost is melted using electric resistance heat. The capacity of the resistive element is specified as a fraction of the heat pump's heating capacity using the following keyword, RESIST-CAP-RATIO.

RESIST-CAP-RATIO

For DEFROST-TYPE = RESISTIVE, this is the ratio of the resistive coil capacity to the heating capacity of the heat pump rated at 47F (8.3C).

DEFROST-CTRL

Takes a code-word that specifies the defrost control action on a heat pump. These control choices apply to DEFROST-TYPE = REVERSE-CYCLE and RESISTIVE

ON-DEMAND

Defrost starts when the capacity of the heat pump drops by approximately 25% due to frost buildup on the coil. The program calculates frost accumulation as a function of outdoor dry-bulb temperature and evaporator coil temperature. For DEFROST-TYPE = REVERSE-CYCLE, the energy to run the compressor to melt the frost and the resultant cooling effect in the zone are calculated. For DEFROST-TYPE = RESISTIVE, the electric resistance energy to melt the frost is calculated.

TIMED

Defrost is controlled by the elapsed operating time of the compressor whether or not frost has actually accumulated. However, defrost does not occur above a user-specified outdoor temperature, DEFROST-T (see following keyword). For DEFROST-TYPE = REVERSE-CYCLE, the compressor energy to defrost for a set period of 3.5 minutes is calculated; the cooling effect produced in the zone is also calculated. For DEFROST-TYPE = RESISTIVE, the electrical energy of the heating element is calculated for 3.5 minutes of defrost time.

DEFROST-T

Outdoor temperature below which the heat pump defrosts itself when it is in the heating mode of operation.

DEFROST-FRAC-FT

Take the U-name of a curve that gives the defrost run time (expressed as a fraction of total run time) as a function of outside wet-bulb and outside dry-bulb temperature. There is no default.

OUTSIDE-FAN-HFLT

For SYSTEM:HEAT-SOURCE = GAS-HEAT-PUMP, takes the U-name of a quadratic curve that is a modifier for outdoor fan power during heating as a function of the heating part load ratio and the condenser entering temperature the value of this curve hourly. This allows the simulation of multi-speed or multi-fan condensing units.

HEAT-CLOSS-FPLR

For SYSTEM:HEAT-SOURCE = GAS-HEAT-PUMP and for HEAT-SOURCE = HEAT-PUMP with COMPRESSOR-TYPE = VARIABLE-SPEED, takes the U-name of a quadratic curve that gives the ratio of the effective compressor output when cycling at minimum speed to the non-cycling output at minimum speed, as a function of the cycling part load ratio. The cycling part load ratio is defined as the heating load divided by the heating capacity at minimum RPM. This curve is used only when the unit is cycling, i.e., whenever the heating load is less than the heating capacity at minimum RPM. It expresses the extra run time needed to make up for cycling losses. The curve is normalized to 1.0 at minimum RPM (cycling part load ratio = 1.0).

HEAT-CLOSS-MIN

For SYSTEM:HEAT-SOURCE = GAS-HEAT-PUMP and for HEAT-SOURCE = HEAT-PUMP with COMPRESSOR-TYPE = VARIABLE-SPEED, this is the minimum cycling part load ratio used as input to HEAT-CLOSS-FPLR.

HEAT-RPM-LIMITS

For SYSTEM:HEAT-SOURCE = GAS-HEAT-PUMP, takes a list of two values. The first value is the maximum RPM during heating; the second value is the minimum RPM during heating. The program uses the ratio of these two numbers.

HEAT-WH-FRPM

For SYSTEM:HEAT-SOURCE = GAS-HEAT-PUMP, takes the U-name of a quadratic curve that describes how the waste heat generated by the engine changes as the RPM of the unit is reduced. The value of the curve is normalized to 1.0 at full RPM.

HEAT-WH-FT

For SYSTEM:HEAT-SOURCE = GAS-HEAT-PUMP, takes the U-name of a quadratic curve that describes how the waste heat generated by the engine changes as the outside air temperature varies. The value of the curve is normalized to 1.0 at ARI outside dry-bulb (47F (8.3C)).

COOL-CAP-FRPM

For SYSTEM:HEAT-SOURCE = GAS-HEAT-PUMP and for HEAT-SOURCE = HEAT-PUMP with COMPRESSOR-TYPE = VARIABLE-SPEED, takes the U-name of a quadratic curve that gives the variation in compressor cooling capacity as a function of the motor RPM. At maximum cooling RPM the curve is normalized to be 1.0. This curve is inverted by the program to obtain the RPM from the unit cooling load.

COOL-EIR-FRPM

For SYSTEM:HEAT-SOURCE = GAS-HEAT-PUMP and for HEAT-SOURCE = HEAT-PUMP with COMPRESSOR-TYPE = VARIABLE-SPEED, takes the U-name of a quadratic curve that gives the variation in the unit EIR as a function of motor RPM. The curve is normalized to 1.0 at maximum cooling RPM. It is used to obtain the part load power consumption of the unit. For variable speed compressors it replaces COOL EIR FPLR used for constant speed units.

COOL-EIR-LS-FT

For SYSTEM:HEAT-SOURCE = GAS-HEAT-PUMP and for HEAT-SOURCE = HEAT-PUMP with COMPRESSOR-TYPE = VARIABLE-SPEED, takes the U-name of a quadratic curve that describes the variation in the EIR at minimum RPM as a function of entering wet-bulb temperature and outside dry-bulb temperature. The program interpolates between this curve and COOL-EIR-FT to obtain the entering wet-bulb - outside dry-bulb correction factor for RPM's between the minimum and the maximum. This curve is also normalized to 1.0 at the ARI rating point.

OUTSIDE-FAN-CFLT

For SYSTEM:HEAT-SOURCE = GAS-HEAT-PUMP, takes the U-name of a quadratic curve that is a modifier for outdoor fan power during cooling as a function of the cooling part load ratio and the condenser entering temperature outdoor fan energy is multiplied by the value of this curve hourly. This allows the simulation of multi-speed or multi-fan condensing units.

COOL-CLOSS-FPLR

For SYSTEM:HEAT-SOURCE = GAS-HEAT-PUMP and for HEAT-SOURCE = HEAT-PUMP with COMPRESSOR-TYPE = VARIABLE-SPEED, takes the U-name of a quadratic curve that gives the ratio of the effective compressor output when cycling at minimum speed to the non-cycling output at minimum speed, as a function of the cycling part load ratio. The cycling part load ratio is defined as the cooling load divided by the cooling capacity at minimum RPM. The curve is used only when the unit is cycling; that is, whenever the cooling load is less than the cooling capacity at minimum RPM. It expresses the extra run time needed to make up for cycling losses. The curve is normalized to 1.0 at minimum RPM (cycling part load ratio = 1.0).

COOL-CLOSS-MIN

For SYSTEM:HEAT-SOURCE = GAS-HEAT-PUMP and for HEAT-SOURCE = HEAT-PUMP with COMPRESSOR-TYPE = VARIABLE-SPEED, this is the minimum cycling part load ratio used as input to COOL-CLOSS-FPLR.

COOL-RPM-LIMITS

For SYSTEM:HEAT-SOURCE = GAS-HEAT-PUMP and for HEAT-SOURCE = HEAT-PUMP with COMPRESSOR-TYPE = VARIABLE-SPEED, takes a list of two values. The first is the maximum RPM during cooling; the second is the minimum RPM during cooling. The program uses the ratio of these two numbers.

COOL-WH-FRPM

describes how the waste heat generated by the engine (COOL-WASTE-HEAT) changes as the RPM of the unit is reduced. The value of the curve is normalized to 1.0 at full RPM.

COOL-WH-FT

For SYSTEM:HEAT-SOURCE = GAS-HEAT-PUMP, takes the U-name of a quadratic curve that gives the variation in the waste heat generated by the engine (COOL-WASTE-HEAT) as a function of entering wet-bulb and outside dry-bulb temperature. The curve is normalized to 1.0 at full load and entering wet-bulb = 67F (19.4C), outside dry-bulb = 95F (35C).

OUTSIDE-FAN-HFLT

For SYSTEM:HEAT-SOURCE = GAS-HEAT-PUMP, takes the U-name of a curve that modifies the outdoor fan power during heating as a function of the heating part load ratio and the outside dry-bulb temperature. The outdoor fan energy is multiplied by the value of this curve hourly. This allows the simulation of multi-speed or multi-fan units.

WASTE-HEAT-USE

Accepts a code-word that specifies how waste heat will be recovered from a DX air conditioner, an electric heat pump or a gas heat pump. If not entered, no heat will be recovered. This keyword works differently for gas heat pumps than the other types of DX units. Allowed code-words are:

SPACE-HEAT

Waste heat will be recovered to satisfy space heating loads. For a DX system, the only space heating load that can be satisfied is the simultaneous central heating load of a packaged multizone system. This code-word has no function for any other system type. MAX-COND-RCVRY specifies the maximum fraction of the design condenser capacity that is recoverable. The default is 100%.

For gas heat pumps, SPACE-HEAT specifies that engine waste heat is recoverable when in the cooling mode, and this waste heat can be used for preheat, reheat, and baseboard heating. For this to happen, specify WASTE-HEAT-USE = SPACE-HEAT or SPACE+DHW-HEAT and specify PREHEAT-SOURCE, ZONE-HEAT-SOURCE, and/or BASEBOARD-SOURCE in the SYSTEM command to be GAS-HYDRONIC. Engine heat will then be applied to these loads and the remaining load will be met by the gas-hydronic boiler. The fraction of gas consumed that is recoverable is specified by COOL-WASTE-HEAT. MAX-COND-RCVRY is not used for a gas heat pump.

DHW-HEAT

Waste heat is to be recovered to a domestic hot water heater. For DX and heat-pump units, only the condenser superheat is recoverable; this is specified using COOL-WASTE-HEAT in the cooling mode and HEAT-WASTE-HEAT in the

heating mode (heat pumps only). Note that MAX-COND-RCVRY is used only when WASTE-HEAT-USE = SPACE-HEAT.

You must also specify the U-name of the DW-HEATER that will receive the recovered heat via the HTREC-DW-HEATER keyword.

For gas heat pumps, DHW-HEAT allows the engine jacket heat to be recovered to a domestic hot water heater, but only when the unit is in the cooling mode. During heating, the jacket heat is always applied toward the main heating load.

SPACE-HEAT+DHW

The unit can recover heat for both space heating and domestic hot water heating. For a DX unit (packaged multizone only), the maximum fraction of design condenser heat recoverable for space heating is specified by MAX-COND-RCVRY, and the fraction of superheat available for domestic water heating is specified by COOL-WASTE-HEAT. Note that the COOL-WASTE-HEAT superheat is a subset of the MAX-COND-RCVRY total heat recoverable. Space heat loads will be satisfied before domestic hot water heating, first using as much of the non-superheat condenser heat as required, and then superheat if still more heat is required. Domestic hot water heating can only recover superheat, and only if any is left over after space heating.

You must also specify the U-name of the DW-HEATER that will receive the recovered heat via the HTREC-DW-HEATER keyword.

Electric heat pumps are similar to DX air conditioners in the cooling mode. In the heating mode, superheat is recovered to domestic hot water heating; this reduces the heat pump's capacity.

For gas heat pumps, SPACE+DHW-HEAT allows the engine jacket heat to be recovered to both miscellaneous space heating loads (gas-hydrionic preheat, zone heat, and/or baseboards) as well as domestic hot water heating. The space heating loads will be satisfied first.

COOL-WASTE-HEAT

For DX air conditioners and electric heat pumps, specifies the fraction of condenser heat that is superheat when operating in the cooling mode. The COOL-WASTE-HEAT is a subset of the MAX-COND-RCVRY, and is used to calculate the superheat available for domestic water heating when WASTE-HEAT-USE = DHW-HEAT or SPACE+DHW-HEAT.

For gas heat pumps, specifies the fraction of the gas consumed that is recoverable from the engine cooling jacket. This heat may be used for either miscellaneous heating loads attached to the heat pump (SYSTEM:PREHEAT-SOURCE, ZONE-HEAT-SOURCE and/or BASEBOARD-SOURCE = GAS-HYDRONIC), as well as domestic hot water heating.

HEAT-WASTE-HEAT

For electric heat pumps, specifies the fraction of condenser heat that is superheat when operating in the heating mode. This superheat may only be used for domestic hot water heating, and acts to reduce the space heating capacity of the heat pump. This keyword is unused for DX air conditioners and gas heat pumps.

HTREC-DW-HEATER

When WASTE-HEAT-USE = DHW-HEAT or SPACE+DHW-HEAT, takes the U-name of the domestic hot water heater (see DW-HEATER command) that receives superheat recovered from the air conditioning unit in the

system. Different air conditioners, electric heat pumps and gas heat pumps can attach to the same or different DW-HEATERS.

UNIT-PUMP-ELEC

For SYSTEM:HEAT-SOURCE = GAS-HEAT-PUMP, this value is used to calculate the pump power during operation of the gas heat pump or its supplemental gas hydronic boiler. The value is specified as watts of pump power divided by the unit's cooling capacity at ARI rated conditions.

UNIT-AUX-KW

For SYSTEM:HEAT-SOURCE = GAS-HEAT-PUMP, this is the power consumption of gas heat pump auxiliaries, such as controls, that operate continuously.

Preheat Equipment

PREHEAT-SOURCE

Takes a code-word that specifies the heat source for the preheat coil, when applicable. The preheat coil is assumed to be in the mixed air, not the outside air.

NONE	No preheating is allowed.
ELECTRIC	The heat source is an electric resistance element.
HOT-WATER	The source of heat is hot water provided by equipment specified in the PLANT input.
FURNACE	The heat source is a furnace (simulated in SYSTEMS).
GAS-HEAT-PUMP	The heat source is a natural-gas engine-driven heat pump. Used only with the PSZ, PVVT, PTAC, RESYS and PVAVS system types.
GAS-HYDRONIC	For the PTGSD system type, specifies that the heat source is a gas-fired hot water generator. For the RESYS system type, specifies that a domestic hot water heater provides hot water to the heating coil.
DHW-LOOP	The heat source is hot water provided by a CIRCULATION-LOOP of TYPE = DHW (domestic hot water). Residential buildings in mild climates sometimes use the domestic water heater to also provide space heat.

PREHEAT-CAPACITY

Total capacity of the preheat coil at design conditions. The input value is negative. If this value is not specified, but PREHEAT-T is specified, then the program will calculate the preheat capacity as a function of the outdoor air quantity, the design outdoor dry-bulb temperature, and PREHEAT-T. Although this keyword is not directly related to pumping, it was added so that the hot-water flow through the preheat coil could be properly simulated.

PREHEAT-T

Minimum temperature of air leaving the preheat coil. The SYSTEMS program calculates the necessary preheat coil energy input to maintain this temperature.

PHW-LOOP

Accepts a code-word which specifies the U-name of the loop to which the central preheat coil in this system is connected. Acceptable loop types are HW and PIPE-2. When sizing the coil, the program checks to see if the coil's leaving air temperature is consistent with the fluid temperature supplied from the circulation loop. The fluid

temperature entering the coil must be at least 10°F warmer than the leaving air temperature, or the program will generate an error. This is true for all of the heating coils (heating, preheat, reheat, etc.) The default is the system's HW-LOOP.

PHW-COIL-DT

Specifies the temperature change through the coil at the coil design conditions. This value is used, together with the design load and loop fluid characteristics, to determine the design coil flow. If not specified, the default is the LOOP-DESIGN-DT of the attached loop.

PHW-COIL-HEAD

Accepts a numeric value which specifies the pressure drop through the coil of the loop fluid at the design flowrate. This value should include the friction losses of the coil's control valve, trim, and any piping associated with the coil and not included in the pressure drop of the loop which serves this coil.

PHW-VALVE-TYPE

Accepts a code-word which specifies the type of coil valve.

- TWO-WAY indicates a valve which will vary the flow through the coil and loop as the load varies.

- THREE-WAY indicates a valve that will vary the flow through the coil as the load varies, but that bypasses the remainder of the design flow around the coil so that the loop flow remains constant.

PHW-COIL-HEAD

Accepts a numeric value which specifies the pressure drop through the coil of the loop fluid at the design flowrate. This value should include the friction losses of the coil's control valve, trim, and any piping associated with the coil and not included in the pressure drop of the loop which serves this coil.

Baseboards and Control

BASEBOARD-SOURCE

Takes a code-word that specifies the heat source for baseboard heating. Allowed values are:

- NONE No baseboard heating is allowed.

- ELECTRIC The heat source is an electric resistance element.

- HOT-WATER The heat source is hot water provided by equipment specified in the PLANT input.

- FURNACE The heat source is a furnace (simulated in SYSTEMS).

- GAS-HEAT-PUMP The heat source is a natural-gas engine-driven heat pump. Used only with the PSZ, PVVT, PTAC, RESYS and PVAVS systems.

- GAS-HYDRONIC For the PTGSD system type, specifies that the heat source is a gas-fired hot water generator. For the RESYS system type, specifies that a domestic hot water heater provides hot water to the heating coil.

DHW-LOOP The heat source is hot water provided by a CIRCULATION-LOOP of TYPE = DHW (domestic hot water). Residential buildings in mild climates sometimes use the domestic water heater to also provide space heat.

BBRD-LOOP

Same as HW-LOOP, but for baseboards. Acceptable loop types are HW and PIPE-2. This keyword also acts as the default for the same keyword which can be specified as the zonal level.

BBRD-COIL-DT

Specifies the temperature change through the coil at the coil design conditions. This value is used, together with the design load and loop fluid characteristics, to determine the design coil flow. This keyword also acts as the default for the same keyword which can be specified as the zonal level. If not specified, the default is the LOOP-DESIGN-DT of the attached loop.

BBRD-COIL-HEAD

Accepts a numeric value which specifies the pressure drop through the coil of the loop fluid at the design flowrate. This value should include the friction losses of the coil's control valve, trim, and any piping associated with the coil and not included in the pressure drop of the loop which serves this coil. This keyword also acts as the default for the same keyword which can be specified as the zonal level.

BBRD-VALVE-TYPE

Accepts a code-word which specifies the type of valve this coil has. This keyword also acts as the default for the same keyword which can be specified as the zonal level.

TWO-WAY indicates a valve which will vary the flow through the coil and loop as the load varies.

THREE-WAY indicates a valve that will vary the flow through the coil as the load varies, but that bypasses the remainder of the design flow around the coil so that the loop flow remains constant.

BASEBOARD-SCH

Takes the U-name of a SCHEDULE (TYPE=RESET-RATIO) that defines the relationship between baseboard heat output and outside air temperature, and specifies the days of the year during which this relationship applies. This keyword applies only if BASEBOARD-CTRL = OUTDOOR-RESET. If BASEBOARD-CTRL = THERMOSTATIC, the program will use HEAT-TEMP-SCH to control the baseboards. Note that the DAY-RESET-SCH keywords SUPPLY-HI and SUPPLY-LO, which usually specify temperatures, are used here to specify baseboard output as a fraction of BASEBOARD-RATING.

You must be careful to avoid shutdown of system heating capability (see HEATING-SCHEDULE) during periods when baseboard heating is desired.

Example input:

```

BASE-DAY-1 = DAY-RESET-SCH
  TYPE                = RESET-RATIO
  SUPPLY-HI           = 1.0
  SUPPLY-LO           = 0.0
  OUTSIDE-HI          = 70.0
  OUTSIDE-LO          = 0.0  . .

```

```

BASE-SCHED-1 = SCHEDULE
  TYPE                = RESET-RATIO
  THRU DEC 31 (ALL)  BASE-DAY-1 ..

SYS-1 = SYSTEM
  BASEBOARD-SCH= BASE-SCHED-1
  . . . .

```

In this example, baseboard heat is fully on for outside temperature below 0F and decreases linearly to zero when the outside temperature reaches 70F.

Staged Fow/Capacity DX cooling/Heating Systems

A staged-capacity HVAC system is a variation of the packaged single-zone systems available in the 7-1/2 ton to 20 ton range. These systems commonly have two compressors, yielding two stages of mechanical cooling. These systems also commonly have two stages of heating, provided by either a gas furnace or a heat pump. The staged-volume concept recognizes that, during the times the unit is not at maximum heating or cooling, it may not be necessary to operate the fan at full output. Compared to constant-volume fan operation, this control strategy can achieve fan energy savings of more than 50% on an annual basis, while simultaneously achieving excellent humidity control in humid climates.

Physically, the system is almost identical to a conventional packaged single-zone system, with the following modifications:

While a packaged single-zone unit typically utilizes two separate refrigerant circuits and a split-faced evaporator coil, a staged-volume unit incorporates either an interlaced coil, or better yet, allows the compressors to share a common circuit. In addition, the unit may utilize a single multi-stage compressor, unequally-sized compressors, or a combination of compressors and multi-stage compressors (up to four stages total). The key idea is that low-stage cooling must utilize the entire evaporator area so that airflow can be reduced without unduly affecting compressor performance.

A variable-speed drive that modulates the fan output as a function of heating/cooling staging, and discharge air temperature.

Control Sequence

The program simulates up to four stages of heating and/or cooling. It is not necessary that heating and cooling have the same number of stages.

Zone thermostat – Like a packaged single-zone unit, the system uses a two-stage heating/cooling thermostat, located in the control zone. Based on zone temperature and heating/cooling setpoints, the thermostat calls for successive stages of heating or cooling.

Discharge air temperature sensor – The unit incorporates a discharge air temperature sensor. As the zone thermostat stages the heating/cooling capacity in a step-wise fashion, the discharge air temperature sensor modulates the fan output to maintain a discharge air temperature setpoint.

Note that the thermostat does NOT modulate the airflow as it would in a VAV system; it stages heating/cooling capacity. The discharge air sensor modulates the airflow. As the thermostat stages heating/cooling capacity, airflow will tend to stage with capacity, hence the term “staged-volume”.

The discharge setpoint may be either constant for all stages of heating or cooling, or may vary with the staging. For example, while the high-stage heating setpoint may be 105°F, it might be desirable to

operate low-stage heating at 95°F. This strategy can reduce temperature stratification in the zone due to the more moderate supply temperature and increased flow rate.

High-stage heating— The unit operates at maximum heat output. Depending on the differential between the discharge-air setpoint and the mixed-air temperature, the fan may be operating at either the maximum output, or at a reduced output to maintain the discharge setpoint. The zone thermostat will cycle the unit between high-stage and low-stage heating as required.

The user may specify the minimum allowable flow ratio. If the airflow must be less than this ratio to maintain the discharge air setpoint, then the flow will be maintained at this setting and the discharge air temperature will float below the setpoint. Also, the discharge air temperature will float above setpoint if the fan cannot maintain the setpoint at 100% output.

Low-stage heating— Similar to high stage heating, except that the fan will typically be operating at a lower output to maintain the low-stage discharge setpoint. The zone thermostat will cycle the unit between high/low/floating stages as required. As with high-stage heating, the fan will not modulate below the minimum allowed flow ratio.

Floating— When the zone temperature is between the heating and cooling setpoints, the user may specify whether the fan is to continue running, or is to cycle off. Note that most codes require that the fan run continuously unless ventilation air is provided by another means. If running, the fan will operate at the minimum allowed flow ratio.

Economizer cooling— When cooling is required and outdoor conditions permit economizer operation, the fan will modulate between the minimum flow ratio and 100% output as required to maintain the zone cooling setpoint. If the economizer delivers more cooling at the minimum flow than the zone requires, then the unit will cycle between the economizer and floating modes. If the economizer cannot meet the entire cooling load, then the unit will cycle between the economizer and low-stage modes.

Low-stage cooling— If economizer operation at 100% output is insufficient to maintain the zone temperature, then low stage cooling will start, and the fan will modulate as required to maintain the low-stage discharge setpoint. The fan may operate as high as 100% output, depending on how much cooling the economizer is providing. (For example, if the mixed air temperature is 60°F, and the low-stage discharge setpoint is 55°F, then low-stage cooling will usually be able to achieve setpoint at maximum fan output.) The fan will not modulate below the minimum flow ratio.

In dry climates where humidity control is not an issue, it might be desirable to specify a low-stage discharge air setpoint higher than the high-stage setpoint to minimize the possibility of diffuser dumping.

High-stage cooling— Similar to low-stage cooling, except that the fan will typically be operating at a higher output to maintain the discharge setpoint. Economizer operation is fully integrated into both low-stage and high-stage cooling.

Subzones— Like the packaged single-zone system, this system may serve more than one zone. The control zone will determine the operation of the system (heating vs. cooling), the supply temperature, and the airflow ratio. Each subzone will receive air at the temperature and airflow ratio as determined by the control zone, and may or may not be comfortable depending on how intelligently the building zones are divided among the systems.

Also like the packaged single-zone system, each subzone may have a reheat coil controlled by its own

thermostat. This can prevent a subzone from being underheated, but cannot prevent a subzone from being undercooled. For reheat, specify the REHEAT-DELTA-T and the zonal HEATING-SCH. The cooling thermostat schedule has no effect on a subzone.

Staged Capacity DX Cooling and Heating

This modeling capability is only available for PVVT systems. Functionally, the staged-volume system is quite similar to the packaged variable-volume, variable-temperature system, and shares its code word.

AIR/TEMP-CONTROL

For the PVVT systems only, accepts a code-word specifying the type of airflow and temperature control employed:

VARIABLE-VOL/TEMP the default, specifies the common PVVT temperature control strategy.

STAGED-VOLUME specifies the staged-volume strategy described herein.

NUM-COOL-STAGES

specifies the number of stages of cooling capacity; specified by the code words ONE, TWO, THREE, or FOUR. The default is two stages, corresponding to a unit with two equally-sized compressors.

COOL-STAGES

accepts a list in parenthesis of numbers specifying the fraction of the full-load sensible capacity associated with each cooling stage. The list must be entered in ascending numerical order, starting with the lowest stage.

For example, the default for a two-stage unit is (0.5, 1.0), corresponding to 50% low-stage capacity, and 100% high stage. High stage is always 100%, regardless of what you enter here. The default for a three-stage unit is (0.33, 0.67, 1.0), etc. While the default staging steps are equal in size, this is not a requirement.

COOL-STAGES-DT

accepts a list in parenthesis of temperature differentials specifying the change in cooling setpoint for each low stage relative to the high stage. These entries correspond to the COOL-STAGES capacities defined above. The default for the lower stages is 0°F; the high stage is always the COOL-SET-T, regardless of what you enter here.

For example, if you have a three-stage unit, the COOL-SET-T is 55°F, and you want to operate the two lower stages at 60°F, enter: (5.0, 5.0, 0.0)

NUM-HEAT-STAGES

specifies the number of stages of heating capacity; specified by the code words ONE, TWO, THREE, or FOUR. The default is two stages, corresponding to a heat-pump with two equally-sized compressors, or a gas furnace with two stages of heating.

HEAT-STAGES

accepts a list in parenthesis of numbers specifying the fraction of the full-load capacity associated with each heating stage. The list must be entered in ascending numerical order, starting with the lowest stage. The number of heating stages does not have to be the same as the number of cooling stages.

For example, the default for a two-stage unit is (0.5, 1.0), corresponding to 50% low-stage capacity, and 100% high stage. High stage is always 100%, regardless of what you enter here. The default for a three-stage unit is (0.33, 0.67, 1.0), etc. While the default staging steps are equal in size, this is not a requirement.

HEAT-STAGES-DT

accepts a list in parenthesis of temperature differentials specifying the change in heating setpoint for each low stage relative to the high stage. These entries correspond to the HEAT-STAGES capacities defined above. The default for the lower stages is -10°F; the high stage is always the HEAT-SET-T, regardless of what you enter here.

For example, if you have a three-stage unit, the HEAT-SET-T is 105°F, and you want to operate the two lower stages at 85°F and 95°F respectively, enter: (-20.0, -10.0, 0.0)

Keywords with Modified Meaning for Staged Capacity Systems

The following are keywords whose meaning is either clarified or modified when used in staged capacity PVVT systems.

MIN-FLOW-RATIO

when *floating* between the heating and cooling setpoints and FAN-CONTROL = CONTINUOUS, specifies the fraction of design flow that the unit delivers.

When *cooling*, specifies the minimum allowable flow ratio. For a given cooling stage, the discharge air sensor modulates the fan output to maintain the discharge temperature setpoint. If the flow ratio falls below this fraction, then the flow will be maintained at this value, and the discharge temperature will float.

HMIN-FLOW-RATIO

when *heating*, specifies the minimum allowable flow ratio. For a given heating stage, the discharge air sensor modulates the fan output to maintain the discharge temperature setpoint. If the flow ratio falls below this fraction, then flow will be maintained at this value, and the discharge temperature will float.

While the default is the same as the MIN-FLOW-RATIO, you might want to specify a higher heating minimum; either to prevent damage to a gas furnace, or to minimize temperature stratification in the zone.

THERMOSTAT-TYPE

This keyword is unused for PVVT systems, however the unit functions as though the thermostat is reverse acting.

Engineering Description

In this description, variables in all capitals are typically keywords.

Definitions of major variables

StgVCoolPLR(n) – the fraction of high-stage cooling capacity for each by stage. By definition, high stage will have a value of 1.0

StgVCoolTset(n) – the cooling supply air temperature setpoint for each stage

StgVCoolT(n) – the actual hourly cooling supply temperature for each stage

StgVCoolCFMr(n) – the actual hourly airflow ratio for each stage

Staging

The user specifies the number of mechanical stages of heating and cooling for the unit. The program adds several additional stages. For cooling,

<u>Stage</u>	<u>Cooling Mode</u>
1	Floating
2	Economizer, if any
3	Low-stage cooling
...	Intermediate stages
Max	High-stage cooling

Note that, if there is no cooling economizer, the economizer stage becomes identical to the floating stage. Heating staging is similar to cooling staging, except there is no economizer stage. In addition, for a heat pum, there is an additional stage for supplemental heat.

<u>Stage</u>	<u>Heating Mode</u>
1	Floating
2	Low-stage heating
...	Intermediate stages
Max-1	High-stage heating
Max	Heat-pump supplemental heat, if any

Beginning of run setup

For each stage, n, transfer the user-specified part-load stages into the working arrays, and calculate the supply temperature setpoint for each stage.

$$\begin{aligned} \text{StgVCoolPLR}(n) &= \text{COOL-STAGES}(n) \\ \text{StgVCoolTset}(n) &= \text{COOL-SET-T} + \text{COOL-STAGES-DT}(n) \\ \\ \text{StgVHeatPLR}(n) &= \text{HEAT-STAGES}(n) \\ \text{StgVHeatTset}(n) &= \text{HEAT-SET-T} + \text{HEAT-STAGES-DT}(n) \end{aligned}$$

Beginning of hour initialization (DKTEMP)

At the beginning of each hour DKTEMP is called to estimate the hourly equipment capacity, and the maximum and minimum possible supply temperatures. Then the routine sets the airflow ratios and supply temperatures for each stage of cooling and heating.

a) Floating between setpoints – if the temperature of the control zone is floating between the heating and cooling setpoints, then neither heating nor cooling is active. The supply temperature is at the mixed-air temperature, and the flow (if the fan is on) is at the minimum airflow:

$$\begin{aligned} \text{StgVCoolT}(n) &= \text{TMMAX} + \text{DuctDT} \\ \text{StgVCoolCFMr}(n) &= \text{MIN-CFM-RATIO} \end{aligned}$$

where

TMMAX the mixed air temperature at minimum outside air, °F
 DuctDT the temperature rise through the ducting, °F
 MIN-CFM-RATIO the minimum allowed airflow ratio

b) Economizer cooling – if outdoor conditions are suitable, the economizer will be operating. The supply temperature is initialized to be the minimum possible economizer temperature, and the airflow to maximum. These values may be reset in VARVOL if the economizer can handle the entire cooling load:

$$\begin{aligned} \text{StgVCoolT}(n) &= \text{TMMIN} + \text{DuctDT} \\ \text{StgVCoolCFMr}(n) &= 1. \end{aligned}$$

where

TMMIN is the economizer temperature, adjusted for fan heat, °F

c) Mechanical cooling – the program assumes the economizer is fully integrated with mechanical cooling, for all stage of mechanical cooling. For any given stage, first calculate the capacity and resulting supply temperature at full airflow:

$$\begin{aligned} \text{Qstg} &= \text{QCS} * \text{StgVCoolPLR}(n) \\ \text{TCstg} &= \text{TMMIN} - \text{Qstg} / (\text{CONS}(1) * \text{SUPPLY-CFM}) \end{aligned}$$

where

Qstg the capacity for a given stage, Btuh
 QCS the hourly temperature-adjusted high-stage cooling capacity, Btuh
 TCstg the supply temperature assuming full airflow, °F
 CONS(1) the air heat transport capacity factor, Btuh/(cfm-dT)
 SUPPLY-CFM the design airflow, cfm

Next, adjust this stage’s temperature setpoint for any dehumidification requirement:

$$\text{Tset} = \text{Min}(\text{StgVCoolTset}(n), \text{TCHUM})$$

where

Tset the desired cooling supply temperature for this stage, °F
 TCHUM the supply temperature required to maintain MAX-HUMIDITY, °F

Compare Tset to TCstg. If TCstg is less than Tset, then the unit can meet the setpoint at full airflow; set the airflow ratio to 1.0. Otherwise, calculate, the maximum airflow the unit can deliver at setpoint, but do not let it drop below the minimum allowable airflow:

$$\begin{aligned} \text{CFMr} &= \text{Qstg} / (\text{CONS}(1) * \text{SUPPLY-CFM} * (\text{TMMIN} - \text{Tset})) \\ \text{CFMr} &= \text{Max}(\text{MIN-CFM-RATIO}, \text{CFMr}) \end{aligned}$$

where

CFMr the fraction of design supply airflow

Finally, calculate the actual supply temperature for this stage:

$$\text{StgVCoolT}(n) = \text{TMMIN} - \text{Qstg}/(\text{CONS}(1)*\text{SUPPLY-CFM}*\text{CFMr}) + \text{DuctDT}$$

d) Heating – the calculations for each heating stage are identical to those for cooling, except there is no economizer stage. If heating is provided by a heat pump, then one extra stage of heating calculations are performed to take into account the supplemental heating that is available in addition to maximum compressor heating.

Hourly calculations (VARVOL and FANPWR)

The staged-volume system is similar to the more conventional PVVT system, and uses many of the same calculations. The staged-volume algorithm recognizes that the unit will typically be cycling between two stages (floating/economizer, economizer/low, low/intermediate, intermediate/high). Each stage is explicitly accounted for so that the fan energy associated with each stage can be calculated accurately.

Like the conventional PVVT system, the control zone is simulated first so that the average supply temperature and airflow can be determined. These values are then passed to the non-control zones, which float according to these values (non-control zones do not have their own temperature control schedules, which is why these types of systems are termed ‘single zone’).

a) Cooling – After the TEMDEV (temperature control) calculations are complete for the control zone, the algorithm cycles through the stages, starting with the lowest, to find stage required to meet the zone’s heat-extraction requirement:

$$\text{Qmax} = \text{CONS}(1) * \text{CFMAX} * \text{StgVCoolCFMr} * (\text{TAVE} - \text{StgVCoolT}(n))$$

where

Qmax	the heat-extraction capacity of this stage, Btuh
CFMAX	the design zonal airflow rate, cfm
TAVE	the average hourly zone temperature calculated in TEMDEV, °F

Next, compare Qmax to the required zonal extraction rate, QNOW. If Qmax is greater, then the maximum required stage has been found; otherwise set Qmin to Qmax and repeat the above for the next higher cooling stage. Once the correct stage has been found, calculate the fraction of the hour the system will be operating at the higher stage:

$$\text{StgVFracHi} = (\text{QNOW}-\text{Qmin}) / (\text{Qmax}-\text{Qmin})$$

where

StgVFracHi	the fraction of the hour the system is at the higher stage
QNOW	the zonal extraction rate required to hold the zone at setpoint, Btuh
Qmax	the capacity of the higher stage, Btuh
Qmin	the capacity of the lower stage, Btuh

The average airflow during the hour is:

$$\text{ZCFM} = \text{CFMAX} * \text{StgVCoolCFMr}(n) * \text{StgVFracHi} + \text{CFMAX} * \text{StgVCoolCFMr}(n-1) * (1-\text{StgVFracHi})$$

and the average supply temperature is

$$TC = TAVE - QNOW / (CONS(1) * CFMZ)$$

where

(n)	references the higher stage of cooling
(n-1)	references the lower stage of cooling
ZCFM	the average airflow during the hour, cfm
TC	the weighted average supply temperature, °F
TAVE	the average zone temperature during the hour, °F
Qmin	the capacity of the lower stage, Btuh

An exception to the above exists if the economizer can handle the entire load. In this case, the airflow ratio will be set to that required to exactly meet the load, and the economizer will be active the entire hour (no cycling between stages).

$$ZCFM = QNOW / (CONS(1) * (TAVE - StgVCoolT(n)))$$

$$StgVCoolCFMr(n) = ZCFM / CFMAX$$

Note that, if the flow ratio is less than the MIN-FLOW-RATIO, then the flow will be held at the minimum, and the supply temperature will be reset.

Finally, calculate the fraction of the hour the fan is running, and the airflow ratio that is passed to the non-control zones. If the fan is specified to run continuously, or the low stage is higher than floating:

$$CFMICYC = 1.0$$

$$CFMVVT = ZCFM / CFMAX$$

If the fan cycles on/off, it will cycle off only if the low stage is the floating stage. During these times:

$$CFMICYC = StgVFracHi$$

$$CFMVVT = StgVCoolCFMr(n), \quad n = \text{index of higher stage}$$

where

CFMICYC	the fraction of the hour the fan is running
CFMVVT	the average airflow ratio passed to the non-control zones.

b) Heating – Heating calculations are identical to the cooling calculations, except there is no economizer. If heating is provided by a heat pump, the highest stage is the combination of compressor and supplemental heating capacity.

c) Fan power – In the above calculations, an average airflow ratio is calculated for the control zone, and this value is used by any other zones in their temperature calculations. However, since the staged-volume system uses a variable-speed drive, and variable-speed power is not linear with airflow, and average airflow ratio cannot be used in calculating fan power. Instead, fan power must be calculated for the airflow ratio associated with each stage, and then weighted by the time each stage was active.

$$PLhi = \text{Max}(\text{MIN-FAN-RATIO}, \text{Min}(\text{MAX-FAN-RATIO}, CFMr(n)))$$

$$PLhi = \text{Curve}(\text{SUPPLY-EIR-FPLR}, PLhi)$$

$$\begin{aligned} \text{PLlo} &= \text{Max}(\text{MIN-FAN-RATIO}, \\ &\quad \text{Min}(\text{MAX-FAN-RATIO}, \text{CFMr}(n-1))) \\ \text{PLlo} &= \text{Curve}(\text{SUPPLY-EIR-FPLR} > \text{PLlo}) \\ \text{PLR} &= \text{PLhi} * \text{StgVFracHi} + \text{PLlo} * (1 - \text{StgVFracHi}) \end{aligned}$$

where

PLhi	fraction of full-load fan power of the higher stage
PLlo	fraction of full-load fan power of the lower stage
PLR	weighted average fraction of full load fan power
MIN-FAN-RATIO	minimum allowed fan ratio; fan bypasses below this point
MAX-FAN-RATIO	maximum allowed fan ratio; usually 1.0

These calculations are repeated for the return fan, if it exists.

All other calculations are done identically to the conventional PVVT system

Fan Coil and Induction Unit Simulation

To simulate a 4-pipe system for TYPE = FC or IU, connect the hot water coil to a HW or STM CIRCULATION-LOOP and the chilled water coil to a CHW CIRCULATION-LOOP. This is the default configuration.

To simulate a 2-pipe system for TYPE = FC or IU, connect the coils to a PIPE2 CIRCULATION-LOOP. Specifying the PIPE2 loop for either the hot water coil or the chilled water coil will automatically cause both heating and cooling to be supplied from the same loop. The head assigned to the coil will be the greater of the values of the HW-COIL-HEAD and the CHW-COIL-HEAD. In a 2-pipe loop, heating and cooling will never both be available the same hour. The loop will change over from heating to cooling according to the changeover criteria specified in the CIRCULATION-LOOP command.

Desiccant cooling units

DESC-CHILLER

When SYSTEM:DESC-HEAT-SOURCE = GAS-CHILLER, takes the U-Name of a gas-fired chiller/heater. The burner of the chiller will fire as necessary to provide both the cooling effect of the chiller as well as satisfy the heating demands of the desiccant system. When a chiller/heater is attached to a desiccant system, the CHILLER:GAS-DESC-XEFF, GAS-HIR-FDESCT, and GAS-QREG-FDESCT keywords also apply.

DESCICCANT = LIQ-VENT-AIR-1

DESC-T-FTW

Takes the U-name of a quadratic curve that gives exit temperature of a desiccant add-on unit as a function of entering air temperature and humidity ratio. Default is DESC-T-FT&W.

DESC-W-FTW

Takes the U-name of a quadratic curve that gives exit humidity ratio of a desiccant add-on unit as a function of entering air temperature and humidity ratio. Default is DESC-T-FT&W.

DESC-GAS-FTW

Takes the U-name of a quadratic curve that gives gas usage of a desiccant unit as a function of entering air temperature and humidity ratio. Default is DESC-T-FT&W.

DESC-KW-FTW

Takes the U-name of a quadratic curve that gives auxiliary kW of a desiccant unit as a function of entering air temperature and humidity ratio. Default is DESC-T-FT&W.

DESICCANT = SOL-VENT-AIR-1 or DESC-CTRL-MODE = 1 or 2**HEAT-EXCH-EFF**

Effectiveness of the sensible heat-exchanger.

HEAT-EXCH-DELP

Pressure drop (inches of water) across the heat-exchanger.

SYSTEM:DESC-HEAT-SOURCE = HOT-WATER**DESC-LOOP**

Takes the U-name of the hot water loop to which the hot water coil in this system is connected. Acceptable loop types are HW, PIPE2 and STM. The default is the system's HW-LOOP.

DESC-COIL-DT

The temperature change through the hot water coil at design conditions. This value is used, together with the design load and loop fluid characteristics, to determine the design coil flow. The default is the CIRCULATION-LOOP:LOOP-DESIGN-DT value of the loop to which the coil is attached.

DESC-VALVE-TYPE

Takes a code-word that specifies the type of valve the hot water coil has. The default is the the valve type given by SYSTEM: HW-VALVE-TYPE.

TWO-WAY

As the load varies, the valve throttles the flow through the coil and loop to maintain the leaving air temperature. No water is bypassed.

THREE-WAY

As the load varies, some of the flow is bypassed around the coil to maintain the leaving air temperature. The loop flow remains constant.

DESC-COIL-HEAD

The fluid pressure drop through the hot water coil at the design flow rate. This value should include the friction losses of the coil's control valve, trim, and any piping associated with the coil and not included in the pressure drop of the loop that serves this coil. The value should be based on the head loss of pure water. The default is the head value given by SYSTEM: HW-COIL-HEAD.

Refrigerated Casework

The following REFG keywords describe the central components of refrigerated casework, such as display fixtures in supermarkets. These keywords describe the operating parameters of the central equipment, such as compressors and condensers. Additional keywords in the ZONE component are used to describe the heat gains of the display fixtures.

REFG-SIZING-RAT

A factor that adjusts the capacity of all compressors in the system. It is the ratio of compressor size to the total evaporator load (which includes the case work and lights, anti-sweat heaters, etc.).

REFG-COMP-CAP

The installed compressor capacity at each of three temperature levels. Takes a list of three values whose order corresponds to the REFG-ZONE-LOAD entries in the ZONE input). Manufacturers of supermarket cases rate compressors at a standard suction temperature that is usually not the actual suction temperature of the case. The input for this keyword must be the compressor capacity at the actual suction temperature of the case. Defaults to (refrigeration equipment design load) x [REFG-SIZING-RAT].

REFG-COMP-EER

Compressor unit efficiency at each of three evaporator temperature levels. Takes a list of three values whose order corresponds to that of the REFG-ZONE-LOAD entries in the ZONE input. If this keyword is not specified, EER vs. evaporator temperature defaults to a linear relationship with EER = 7.3 Btuh/W at 25F and 3.5 Btuh/W at -30F.

REFG-COMP-GROUP

Takes a list of code-words at each of three evaporator temperature levels that specify whether the compressors serve separate refrigeration circuits or are multiplexed. The allowed code-words are:

- SEPARATE The compressors serve separate refrigeration circuits.
- COMMON The compressors are multiplexed.

For example, if the first (lowest temperature level) is separate, and the other two levels are multiplexed, then REFG-COMP-GROUP = (SEPARATE, COMMON, COMMON). An incorrect input such as (SEPARATE, COMMON, SEPARATE) will be interpreted as (SEPARATE, SEPARATE, SEPARATE). When separate refrigeration circuits share a common compressor, the compressor must operate at a suction temperature low enough to match the coldest evaporator temperature in the multiplexed circuits. The energy consumption of the compressor is determined as though the total load of the multiplexed circuits occurred at the coldest evaporator temperature.

Multiplexing circuits will affect the input of other keywords pertaining to the compressors. Consider the following input for three circuits:

```
REFG-COMP-GROUP = ( COMMON , COMMON , SEPARATE )
REFG-COMP-EER   = (   3.5 ,   20.0 ,    5.7 )
```

Because the first two circuits are multiplexed, the program will use 3.5 Btuh/W to calculate the energy consumption of the compressor serving these two circuits. The value of 20.0 Btuh/W for the second circuit is ignored. It (or any other legal value) was input simply to mark the second position in the list so that the value for the third circuit could be input in the third position.

REFG-FAN-KW

The power of the fans of air-cooled condensers or the fans of cooling towers.

REFG-PUMP-KW

The condenser water pump power for cooling towers.

REFG-MIN-COND-T

The setpoint of a thermostat, located in the outside air, that modulates the condensing capacity of either air-cooled condensers or cooling towers so as to maintain a condensing temperature that is approximately 10F (5.6C) higher than the setpoint. In situations where the condensing temperature is not allowed to float, this value should be set 10F (5.6C) lower than the rated condensing temperature of the equipment.

REFG-MAX-HTREC

The maximum amount of heat that can be recovered from the compressors. The default assumes that all heat rejected by the compressors is recoverable.

REFG-HTREC-GROUP

Takes a code-word that determines if all the compressors switch together to a higher condensing temperature for heat recovery or do so independently.

COMMON	Whenever the space requires heating, all of the compressors switch to the heat recovery mode and to the higher condensing temperature.
SEPARATE	The compressors operating at the highest evaporator temperature are the first to switch to the heat recovery mode and are thus forced to operate at a higher condensing temperature (given by REFG-HTREC-T).

REFG-HTREC-UNITS

Takes a list of three code-word values that determine whether the compressors operating at each of three different evaporator levels are available for heat recovery. For example, REFG-HTREC-UNITS = (NO, YES, YES) means that compressors operating at the first evaporator temperature level are not available for heat recovery, but the compressors operating at the second and third levels are available for heat recovery. The order of the list of three entries should correspond to the REFG-ZONE-LOAD entries in the ZONE input.

REFG-HTREC-T

The condensing temperature setpoint in the heat recovery mode.

REFG-FAN-T

The low-limit setpoint temperature at which the condenser fans shut off.

REFG-DIRECT-FRAC

The fraction of case-to-space load that goes directly back to the return air duct or plenum. The program assumes this occurs through ductwork that picks up cold air spilling out of the cases and carries it back to the return where it is mixed with zone's return air and outside air and then passed to the conditioning coils and supply fan. This decreases the return air temperature and results in a lower supply air temperature.

REFG-COND-TYPE

Takes a code-word that specifies how the condenser is cooled. Allowed values are:

AIR-COOLED	Air-cooled condenser.
EVAP-CONDENSER	Evaporatively-cooled condenser.
WATER-COOLED	The condensers are attached to a CIRCULATION-LOOP (usually a CW loop, but possibly a WLHP or CHW loop). The U-name of the CIRCULATION-LOOP is given by the REFG-CW-LOOP keyword.

REFG-CW-LOOP

For REFG-COND-TYPE = WATER-COOLED, takes the U-name of the CIRCULATION-LOOP to which the refrigeration condensers are attached.

REFG-CW-HEAD

Accepts a numeric value that specifies the pressure drop through the coil of the loop fluid at the design flowrate. This value should include the friction losses of the coil's control valve, trim, and any piping associated with the coil

and not included in the pressure drop of the loop that serves this coil. The value should be based on the head loss of pure water.

REFG-CW-VALVE

Takes a code-word that specifies the type valve on this coil.

- TWO-WAY Two-way valve that will vary the flow through the coil and loop as the load varies.
- THREE-WAY Three-way valve that will vary the flow through the coil and loop as the load varies, but that bypasses the remainder of the design flow around the coil so that the loop flow remains constant.

REFG-CW-DT

The temperature change through the coil at the coil design conditions. This value is used, together with the design load and loop fluid characteristics, to determine the design coil flow. If not specified, the default is the LOOP-DESIGN-T of the attached loop.

REFG-COND-CTRL

Accepts a code-word that defines the method used to control the condenser capacity. It applies when CONDENSER-TYPE = AIR-COOLED or EVAP-CONDENSER and when REFG-SETPT-CTRL = FIXED or VARIABLE. The value of this code-word is used to select a library entry to use for the keyword REFG-FAN-PWR-FPL, as follows:

REFG-SETPT-CTRL

Takes a code-word that specifies the method used to control the condenser temperature setpoint for REFG-COND-TYPE = AIR-COOLED and EVAP-CONDENSER. Allowed values are:

- VARIABLE For REFG-COND-TYPE = AIR-COOLED, the condensing temperature setpoint = [ambient dry-bulb temperature] + REFG-SETPT-VAL.

For REFG-COND-TYPE = EVAP-COOLED, the condensing temperature setpoint = [ambient wet-bulb temperature] + REFG-SETPT-VAL.
- FIXED The condensing temperature setpoint is REFG-SETPT-VAL.
- AMBIENT The condensers are controlled by cycling the fans. This means that the condensing temperature floats and is determined by the ambient temperature, number of fans operating, and total hourly heat of rejection.

REFG-SETPT-CTRL is ignored when the REFG-COND-TYPE = WATER-COOLED. In this case temperature control is specified through the appropriate CIRCULATION-LOOP keywords.

REFG-SETPT-VAL

The condensing temperature setpoint when the REFG-COND-TYPE = AIR-COOLED or WATER-COOLED. For REFG-SETPT-CTRL = FIXED, this is the condensing temperature that the condenser tries to maintain. For REFG-SETPT-CTRL = VARIABLE, this is the offset from the ambient dry-bulb temperature (for REFG-COND-TYPE = AIR-COOLED) or the offset from the ambient wet-bulb temperature. The default is 5F (-15C) when REFG-SETPT-CTRL = FIXED and 10F (-12.2C) when REFG-SETPT-CTRL = VARIABLE. Unused for REFG-SETPT-CTRL = AMBIENT.

REFG-AMB-COND-FT

Required when REFG-SETPT-CTRL = AMBIENT. Takes the U-name of a curve that gives the fractional condenser capacity as a function of ambient dry-bulb temperature (for REFG-COND-TYPE = AIR-COOLED) or as a function of ambient wet-bulb temperature (for REFG-COND-TYPE = EVAP-COOLED). This curve is used to calculate the condenser capacity and the condenser fan power. The default is the library curve Refg-Amb-Condenser-Frac/Pwr-ft.

REFG-COND-SIZE

Takes a list of values of condenser capacity (the total heat the condenser can reject) for each of up to three compressor groups. For REFG-COND-TYPE = AIR-COOLED, the value to input for each compressor group is the capacity per degree of ambient dry-bulb and condensing temperature (Btu/hr-F or W/K) at the design ambient dry-bulb and condensing temperature. For REFG-COND-TYPE = EVAP-CONDENSER or WATER-COOLED, the value to input for each compressor group is the capacity (Btu/hr or W) at design ambient wet-bulb and condensing temperature. For REFG-COND-TYPE = EVAP-CONDENSER, the design condition used must be the same as that at which the REFG-COND-CAP-FT curve is normalized.

The default value for the condenser size is the design load plus compressor power for each compressor group. For REFG-COND-TYPE = AIR-COOLED, this is divided by a temperature differential of 10F (5.6K).

REFG-COND-CAP-FT

For REFG-COND-TYPE = EVAP-CONDENSER, this is a required keyword that takes the U-name of a curve that gives the condenser capacity as a function of condensing temperature and ambient wet-bulb temperature. The curve values are the condenser operating capacity divided by the condenser capacity at design wet-bulb and condensing temperature. The default is the curve Refg-Condenser-Cap-fCondT&WBT. This keyword replaces TWR-APP-FRACT used in previous versions of the program.

REFG-FAN-PWR-FPL

For all REFG-COND-TYPES, this is a required keyword that takes the U-name of a curve that gives the condenser fan power as a function of part load ratio. The part load ratio is defined as the total heat rejected by the condenser in a given hour divided by the operating capacity of the condenser that hour. See the description of REFG-COND-CTRL for default values. This keyword replaces TWR-RFACT-FRT used in previous versions of the program.

REFG-ASH-KW

Takes a list of values of anti-sweat heater power for each of up to three sets of cases. All anti-sweat heater energy is added to the refrigeration auxiliary category.

REFG-ASH-LOWW

The return air humidity ratio at which the anti-sweat heaters begin to operate. The heater power is assumed to increase linearly from zero at REFG-ASH-LOWW to 100% at REFG-ASH-HIGHW. If REFG-ASH-HIGHW is 0.0, the anti-sweat heaters turn on at full power when the return air humidity reaches REFG-ASH-LOW.

REFG-ASH-HIGHW

The return air humidity ratio at which the anti-sweat heaters operate at full power. The heater power is assumed to increase linearly from zero at REFG-ASH-LOWW to 100% at REFG-ASH-HIGHW. If REFG-ASH-LOWW = REFG-ASH-HIGHW, the heaters go from zero to full power at this humidity ratio.

REFG-AUX-FRAC

The fraction of the REFG-AUX-KW values and the REFG-ASH-KW values that is seen as a load on the case compressors. The remainder is seen as a cooling load in the ZONE that contains the casework. All of the REFG-AUX-KW and REFG-ASH-KW electrical energy is attributed to the refrigeration end-use category.

REFG-KW-FTCOND

Accepts a list of three U-names of curves (listed in order of lowest to highest suction temperature) of that give the ratio of compressor power input at an operating condensing temperature to that at design (rated) condensing temperature. The default is (Refg-kW-fECT-T1, Refg-kW-fECT-T2, Refg-kW-fECT-T3).

REFG-KW-FPLR

Accepts a list of three U-names of curves (listed in order of lowest to highest suction temperature) that give the ratio of compressor power input at an operating load fraction (PLR) to that at design (rated) capacity. The default is (Refg-kW-fPLR, Refg-kW-fPLR, Refg-kW-fPLR).

REFG-HREC-T

The setpoint temperature used for heat recovery operation. This value will control the condensing temperature "seen" by the compressors when the system is in heat recovery mode (hold-back valve operation).

REFG-HREC-STAGE1

The fraction of total heat rejection recoverable from superheat from the compressors in their normal operating mode (the first stage of heat recovery). If the heating demand is above this amount the second stage of heat recovery is entered and the REFG-KW-HR-FTC curves are used (see REFG-HREC-STAGE2).

REFG-HREC-STAGE2

The fraction of total heat rejection recoverable from the compressors in their holdback operating mode (the second stage of heat recovery). The REFG-KW-HR-FTC curves are used to calculate compressor power in this stage. If the heating demand is below this amount the compressors are run fractionally in both stages of heat recovery to match the heating demand.

REFG-KW-HR-FTC

Takes a list of U-names of curves that give compressor power (during stage 2 of heat recovery) as a function of condensing temperature for each of up to three compressor groups. The compressor power is calculated by applying this curve to REFG-COMP-EER. The default value is (Refg-kW2-fECT-T1, Refg-kW2-fECT-T2, Refg-kW2-fECT-T3).

REFG-WALKIN-LOAD

The design load on the refrigeration circuit for all walk-in boxes (or other preparation/storage rooms.) The value is specified in Btu/hr. If not specified, there are no box loads.

REFG-WALKIN-SCH

Takes the U-name of a SCHEDULE of TYPE = FRACTION or MULTIPLIER whose hourly value multiplies REFG-WALKIN-LOAD to produce the actual value of the load added to the specified compressor group to account for the walk-in loads. The default value is a schedule whose value is always 1.0.

REFG-WALKIN-LOC

Takes a code-word that indicates which compressor group the walk-in load is to be added. Allowed values are:

ICE-TEMP-COMP	Add walk-in load to first group in list.
LOW-TEMP-COMP	Add walk-in load to second group in list.
MED-TEMP-COMP	Add walk-in load to third group in list.

Meters

The following -METER keywords specify electric and fuel metering at the SYSTEM level. The program has a hierarchy of meter defaulting that starts at the MASTER-METER level, and works its way down through SYSTEMs to the ZONE level:

The electric end-use meters at the MASTER-METER level default to the MASTER-METER's MSTR-ELEC-METER. Fuel meters default in the same way.

The electric end-use meters at the SYSTEM level default to the SYSTEM's MSTR-ELEC-METER, or if not specified, to the MASTER-METER's end-use meter of the same type. For example, a SYSTEM's LIGHT-ELEC-METER will default to the SYSTEM's MSTR-ELEC-METER, or to the MASTER-METER's LIGHT-ELEC-METER. The MASTER-METER's LIGHT-ELEC-METER in turn defaults to the MASTER-METER's MSTR-ELEC-METER. Fuel meters default in a similar fashion.

The electric end-use meters at the ZONE level default to the ZONE's MSTR-ELEC-METER, or if not specified, to its parent SYSTEM's end-use meter of the same type. The parent SYSTEM's end-use meter in turn defaults to the SYSTEM's MSTR-ELEC-METER, or if not specified, to the MASTER-METER's end-use meter of the same type. The MASTER-METER's end-use meters in turn default to the MASTER-METER's MSTR-ELEC-METER. Fuel meters default in a similar fashion.

Since central plant equipment (boilers, chillers, etc.) can span across multiple ZONEs and multiple SYSTEMs, their meters default directly to the appropriate end-use meters at the MASTER-METER level.

If you do nothing but specify the MASTER-METER's MSTR-ELEC-METER and MSTR-FUEL-METER, all meters in all components will default to those meters.

MSTR-ELEC-METER

Accepts the U-name of the electric meter to be used as the SYSTEM's master electric meter. All electric meter attachments in all of this SYSTEM's components and in all of this SYSTEM's child ZONE components will default to this meter unless specified otherwise within the component definition.

MSTR-FUEL-METER

Accepts the U-name of the fuel meter to be used as the master fuel meter. All fuel meter attachments in all of this SYSTEM's components and in all of this SYSTEM's child ZONE components will default to this meter unless specified otherwise within the component definition..

LIGHT-ELEC- METER

Accepts the U-name of the electric meter to be used as the master electric meter for all general lighting. The default is the MSTR-ELEC-METER.

TASK-ELEC-METER

Accepts the U-name of the electric meter to be used as the master electric meter for all task lighting. The default is the MSTR-ELEC-METER

EQUIP-ELEC-METER

Accepts the U-name of the electric meter to be used as the master electric meter for all miscellaneous equipment (computers, copiers, etc.). The default is the MSTR-ELEC-METER.

SOURCE-ELEC-METER

Accepts the U-name of the electric meter to be used as the master electric meter for all source usage. The default is the MSTR-ELEC-METER.

HEAT-ELEC-METER

Accepts the U-name of the electric meter to be used as the master electric meter for all space heating. The default is the MSTR-ELEC-METER.

COOL-ELEC-METER

Accepts the U-name of the electric meter to be used as the master electric meter for all space cooling. The default is the MSTR-ELEC-METER.

HTREJ-ELEC-METER

Accepts the U-name of the electric meter to be used as the master electric meter for all heat-rejection equipment (cooling towers, etc.). The default is the MSTR-ELEC-METER.

AUX-ELEC-METER

Accepts the U-name of the electric meter to be used as the master electric meter for all HVAC auxiliary equipment (pumps, etc.). The default is the MSTR-ELEC-METER.

VENT-ELEC-METER

Accepts the U-name of the electric meter to be used as the master electric meter for all ventilation fans. The default is the MSTR-ELEC-METER.

REFG-ELEC-METER

Accepts the U-name of the electric meter to be used as the master electric meter for all refrigeration equipment. The default is the MSTR-ELEC-METER.

SUPP-ELEC-METER

Accepts the U-name of the electric meter to be used as the master electric meter for all supplemental heating in electric heat-pumps. The default is the MSTR-ELEC-METER.

DHW-ELEC-METER

Accepts the U-name of the electric meter to be used as the master electric meter for all water heating equipment. The default is the MSTR-ELEC-METER.

SOURCE-FUEL-METER

Accepts the U-name of the electric meter to be used as the master fuel meter for all source usage. The default is the MSTR-FUEL-METER.

HEAT-FUEL-METER

Accepts the U-name of the electric meter to be used as the master fuel meter for all space heating. The default is the MSTR-FUEL-METER.

COOL-FUEL-METER

Accepts the U-name of the electric meter to be used as the master fuel meter for all space cooling. The default is the MSTR-FUEL-METER.

SUPP-FUEL-METER

Accepts the U-name of the fuel meter to be used as the master fuel meter for all supplemental heating in electric heat-pumps. The default is the MSTR-FUEL-METER.

DHW-FUEL-METER

Accepts the U-name of the fuel meter to be used as the master fuel meter for all domestic water heating equipment. The default is the MSTR-FUEL-METER.

Zone Terminal Keywords

The following keywords provide information on the characteristics of heat transfer, flow throttling, or air induction components that control individual zone temperatures. These parameters are the same for all zones served by the system. You are cautioned that, at the present time, the values of REHEAT-DELTA-T and INDUCTION-RATIO must be identical for all zones served by the system. MIN-FLOW-RATIO can be supplied separately at the zone level also.

REHEAT-DELTA-T

Maximum increase in temperature for supply air passing through the zone (or subzone) reheat coils. The value specified here applies to all zones in the system. This keyword is required in order to simulate heating the air as it passes through the terminal reheat coil. Note that when very little air is passed (see MIN-FLOW-RATIO) there may be insufficient reheating.

MIN-FLOW-RATIO

The minimum flow rate of a VAV or PIU box expressed as a fraction of design air flow. Applies only to variable-volume type systems. If ZONE:THERMOSTAT-TYPE = REVERSE-ACTION the flow rate reduces to MIN-FLOW-RATIO on a drop in zone temperature. As the zone temperature drops even more, the terminal reheat is first enabled, then the air flow rate of the box increases to satisfy the heating load. If MIN-FLOW-RATIO is less than MIN-OUTSIDE-AIR, 100% outside air flow will be simulated when the supply flow ratio is below MIN-OUTSIDE-AIR flow. When simulating a VAV system, the value of ZONE:THROTTLING-RANGE should be at least 4F (2.2K) to insure stability of operation. This is especially true when a COLDEST or WARMEST control option in HEAT-CONTROL or COOL-CONTROL is also used.

Any hourly value of MIN-FLOW-SCH entered in the ZONE command will override the value of MIN-FLOW-RATIO. For example, a MIN-FLOW-SCH value of 1.0 will force the box to be fully open, which is typical for a warm-up cycle. A MIN-FLOW-SCH value of -999 returns the minimum stop to either the value input or to that calculated by the program.

For dual-duct VAV systems (including multizone), this keyword corresponds to the minimum air flow ratio at the outlet of the mixing box. The keywords, CMIN-FLOW-RATIO and HMIN-FLOW-RATIO, correspond to the minimum air flow ratio at the inlet of the mixing box. Therefore, MIN-FLOW-RATIO should be specified only when the mixing box has a controller on the outlet, or if the mixing is constant-volume.

The default for MIN-FLOW-RATIO is 0.0 for dual-fan systems, 1.0 for multizone systems, and the minimum zone ventilation requirement for single-fan dual-duct systems. Ventilation air for dual-fan systems is assumed to be provided by the cold duct controller via the SYSTEM:CMIN-FLOW-RATIO keyword.

For a constant-volume dual-duct (or multizone) mixing box, MIN-FLOW-RATIO should be 1.0. It can have smaller values for other types of variable-volume control strategies. It should not be specified if the box is variable-volume but does not have a controller monitoring air flow at the outlet. Because the mixing box is controlled according to its heating/cooling setpoints, air flow will vary at the outlet. When the air flow at the outlet drops below MIN-FLOW-RATIO, the controller will cause additional air to be made up from the duct specified by MIN-FLOW-SOURCE.

MIN-FLOW/AREA

Minimum air flow rate per unit floor area. An alternative to specifying MIN-FLOW-RATIO. The program will multiply this value by the floor area of the zone to determine the minimum air flow allowable, and divide by the

peak cooling air flow to determine the minimum flow ratio. This minimum flow ratio is then used in the hourly simulation. If you allow the program to determine the design heating air flows, they will be at least this value.

Note that for multizone or packaged multizone systems, MIN-FLOW-RATIO defaults to 1.0. To make these system types variable-volume, with the minimum flow specified through MIN-FLOW/AREA, MIN-FLOW-RATIO must be set to a very small number (such as 0.00001). Otherwise, the minimum will default to the larger of MIN-FLOW/AREA and MIN-FLOW-RATIO, which in this case will be 1.0.

INDUCTION-RATIO

For IU systems only, the ratio of induced air flow to primary air flow. This entry is applicable to the IU system type, but not to the variable-ratio ceiling induction units used for subzone temperature control (SZCI system type), which have a preprogrammed value of 1.0. The value input for INDUCTION-RATIO applies to all zones in the system.

CMIN-FLOW-RATIO

For dual-duct and multizone systems, this is the minimum air flow ratio of the controller that modulates the cold duct damper at the inlet of the mixing box. If the mixing box does not have a controller at the inlet, then this keyword could be set to a small value, such as 0.05, to approximate cold air leakage that occurs when the damper is fully closed (zone in heating mode or deadband). For single-fan dual-duct and multizone systems, the ventilation air can be delivered via either the hot or cold duct. For dual-fan systems, ventilation air is assumed to always come from the mixed air/cold deck side of the system because the program may not otherwise be able to provide sufficient ventilation air under all conditions. To prevent the program from guaranteeing sufficient ventilation air, you may let this keyword default to 0.01 or you may override the value on an hourly basis by using ZONE:CMIN-FLOW-SCH.

CMIN-FLOW/AREA

For dual-duct and multizone systems, the minimum cold duct air flow per unit floor area. Similar to MIN-FLOW/AREA. An alternative to specifying CMIN-FLOW-RATIO. If you allow the program to determine the design cooling air flow, it will be at least this value.

MIN-FLOW-SOURCE

For a dual-duct or multizone system, takes a code-word that specifies the source of the makeup air used by the outlet controller when the total supply air flow falls below MIN-FLOW-RATIO.

COLD-DUCT	The makeup air is drawn from the cold duct.
HOT-DUCT	The makeup air is drawn from the hot duct.
SNAP-ACTING	The makeup air to be drawn from the hot duct during the heating mode and from the cold duct during the cooling mode. When in the deadband, the makeup air is drawn from whichever mode was last active. Note that a snap-acting controller, together with a large MIN-FLOW-RATIO, may cause the zone temperature to oscillate back and forth between the heating and cooling setpoints.

HMIN-FLOW-RATIO

For dual-duct systems, this is the minimum air flow ratio of the controller that modulates the hot duct damper at the inlet of the mixing box. Not all dual-duct mixing boxes have such a controller. In this case, this value represents the hot air leakage that occurs when the damper is fully closed (zone in cooling mode or deadband). If the hot duct has a controller, but the controller monitors the air flow on the outlet of the box rather than the inlet, then MIN-FLOW-RATIO should be specified for the outlet and MIN-FLOW-SOURCE specified to be HOT-DUCT. HMIN-FLOW-RATIO would then be a small value (such as 0.01, the default) to approximate hot air leakage when the damper is fully closed.

For single duct systems, with ZONE:THERMOSTAT-TYPE = PROPORTIONAL, this keyword has a special meaning. Usually, the VAV box will be at MIN-FLOW-RATIO during heating (the thermostat type must be REVERSE-ACTION to cause the box to fully reopen during heating). Specifying HMIN-FLOW-RATIO to a value greater than MIN-FLOW-RATIO will cause the box to jump to the flow corresponding to the HMIN-FLOW-RATIO whenever the zone requires heating, rather than staying at MIN-FLOW-RATIO. During cooling or deadband modes, the box will modulate down to the MIN-FLOW-RATIO as before. At least one manufacturer of controls for VAV reheat boxes uses this strategy. The idea is to allow the deadband cooling airflow to drop to a low (energy-efficient) value, but to ensure that sufficient airflow exists for reheating, and to prevent excessive temperature stratification between the floor and ceiling during reheat.

HMIN-FLOW/AREA

Has the same meaning as HMIN-FLOW-RATIO but is expressed as a flow per unit floor area. If you allow the program to determine the design heating air flows, the design heating air flow will be at least this value.

Miscellaneous

FUNCTION

Invokes a function calculation for the system. Takes a list of two U-names, enclosed in asterisks, of previously-defined FUNCTION commands. If the U-names are U-name1 and U-name2, possible assignments are as follows:

FUNCTION = (*U-name1*, *NONE*)

FUNCTION = (*NONE*, *U-name2*)

FUNCTION = (*U-name1*, *U-name2*)

In the first case, the calculation of the function with NAME = *U-name1* will be done before the execution of the subroutine associated with the function. In the second case, the calculation of the function with NAME = *U-name2* will be done after the execution of the subroutine associated with the function. In the third case, the function with *U-name1* will be calculated before, and the function with *U-name2* will be calculated after the subroutine's execution.

SYSTEMS-REPORT

Determines if non-hourly reports (SUMMARY and VERIFICATION) are to be produced for this SYSTEM. YES indicates that all requested reports are to be produced.

SYSTEMS-REPORT

Specifies which of the standard verification and summary reports to print. Examples of these reports along with a description of each can be found in *DOE-2.2 Libraries & Reports*. Verification reports echo your input in a modified form or show results of system sizing. Summary reports show calculation results, usually monthly and annually. The time period covered in the summary reports is given by BEGIN-MONTH, BEGIN-DAY, END-MONTH and END-DAY in the RUN-PERIOD command. The example below shows how to print verification report SV-A, "System Design Parameters," and summary reports SS-A, "System Monthly Loads Summary," and SS-O, "Temperature Scatter Plot."

Example Input:

```
SYSTEMS-REPORT
  VERIFICATION      = (SV-A)
  SUMMARY           = (SS-A, SS-O) ..
```

VERIFICATION

Takes a list of code-words that identify the SYSTEMS verification reports to be printed. See *DOE-2.2 Libraries & Reports*.

- SV-A SYSTEM DESIGN PARAMETERS FOR <system name>
This report echoes your input to the program for each system as interpreted by the SYSTEMS design routines. See "DESIGN-DAY Command" in the *DOE-2.2 Topics*. The report is divided into three sections: System-Level Design Values, Fan Design Values and Zone-Level Design Values. For systems having mixing sections (dual-duct and multizone systems) an additional section appears detailing the cold duct, hot duct, and total zonal air flows, as well as the minimum air flow ratios for these quantities. Note: the quantities in this report have been adjusted for altitude even though the program requires that any flows you enter in SYSTEMS be at sea level.
- SV-A SYSTEM DESIGN PARAMETERS (REFRIGERATED EQUIPMENT IN <space name>)
When refrigerated equipment is input, an alternate SV-A report is printed. The top half of the report is identical to that as previously described. The bottom half, titled REFRIGERATED EQUIP IN <space name>, covers the design parameters for three categories: ZONE, COMPRESSOR, and CONDENSER.
- SV-B ZONE FAN DATA PIU <system name>
This report is produced whenever a Powered Induction Unit (PIU) system is specified.

SUMMARY

Takes a list of code-words that identify the SYSTEMS summary reports to be printed. See *DOE-2.2 Libraries & Reports*.

- SS-A SYSTEM MONTHLY LOADS SUMMARY <system name>
This report is always printed by the program for each HVAC system modeled. It shows monthly cooling, heating and electrical loads. The loads shown are the sum of zone-level loads and central air-handling-unit loads. (Zone-level loads are

shown separately in Report SS-G.). This report is for comparison of monthly cooling and heating needs for the HVAC system. DX cooling loads are reported here (for PSZ, PMZS, PVAVS, PTAC, PVVT, RESVVT, RESYS and RESYS2 systems) but are not passed to the PLANT program.

- SS-B SYSTEM MONTHLY LOADS SUMMARY FOR <system name>
This is a summary of the heating and cooling required by all the zones (combined) served by the HVAC system. The items summarized are zone-level cooling, zone-level heating, zone baseboard heating, and preheat energy. In addition, this report lists the preheat energy required and the peak preheat load. The preheat coils raise the temperature of the mixed air to a specified temperature. When you specify baseboard heating in a zone the heating supplied is reported under the heading BASEBOARD HEATING ENERGY.
- SS-C SYSTEM LOAD HOURS FOR <system name>
The number of cooling and heating hours and fan operating hours for each month are reported for the system. Included are the hours when both heating and cooling are required. In addition, this report gives the heating and electrical loads at the time of the cooling peak. Note: the hour counts in this report are incremented by 1.0 when the relevant condition (e.g., "fans on") applies for all or part of the hour.
- SS-D BUILDING HVAC LOAD SUMMARY
The cooling, heating and electrical energy required by the systems and zones served by the central plant are reported monthly along with the peak cooling, heating and electrical loads for the combined systems, and the time of occurrence. Note that these peak loads may result from startup after the building has been shut down overnight. Cooling done in SYSTEMS by DX units is not included here in cooling loads but in electrical loads.
- SS-E BUILDING HVAC LOAD HOURS
Just as the monthly load hours are reported for an HVAC system in Report SS-C, the combined load hours for all of the HVAC systems served by the central plant are shown in this report. Heating and electrical loads for the plant at the time of the cooling peak are also reported. Note: the hour counts in this report are incremented by 1.0 when the relevant condition (e.g., "fans on") applies for all or part of the hour.
- SS-F ZONE DEMAND SUMMARY FOR <zone name>
For a zone, this report gives monthly monthly sums for zone heating and cooling demands from the HVAC system, minimum and maximum zone air temperatures, and the number of hours the loads are not met in the zone.
- SS-G ZONE LOADS SUMMARY FOR <zone name>
Zone cooling, heating and electrical requirements are reported in this monthly summary. The cooling and heating energy reported is supplied only at the zone level (such as for reheat coils). Often heating and cooling loads are reported as zero in this report when the central HVAC system (e.g., a dual-duct system) provides all the heating and cooling.
- SS-H SYSTEM UTILITY ENERGY USE FOR <system name>
This report gives monthly values of electrical energy for fans, gas/oil energy for

heating and cooling, and electrical energy for heating and cooling for an HVAC system.

- SS-I SENSIBLE/LATENT SUMMARY FOR <system name>
This is a summary of the monthly cooling and heating energy provided by each HVAC system. The quantities shown are the sum of zone-level loads and central air-handling-unit loads.
- SS-J PEAK HEATING AND COOLING FOR <system name>
For each HVAC system, this report gives an hourly profile of three types of peak day that occur during the RUN-PERIOD:
- SS-K SPACE TEMPERATURE SUMMARY FOR <system name>
This report gives a monthly summary of various temperature quantities for the spaces served by an HVAC system. It can be used to determine the potential for night ventilation as a cooling strategy. Blank entries indicate that no hours existed in a particular category. The averages given are over all spaces served by the system.
- SS-L FAN ELECTRIC ENERGY USE FOR < system name>
This report gives a breakdown of monthly electric energy for fans (central and zone-level) and fan part load operation for an HVAC system.
- SS-M BUILDING HVAC FAN ELEC ENERGY
This report gives a breakdown of electric energy used by all fans in the building.
- SS-N RELATIVE HUMIDITY SUMMARY FOR <system name>
In this scatter plot, the vertical axis, at the left, shows relative humidity bins. The horizontal axis, at the top, shows hours of the day (in local standard time), where "1AM" is midnight to 1:00am, "2" is 1:00am to 2:00am, etc. The cells of the plot contain number of hours during the run period for which the relative humidity of the system return air was in the particular relative humidity bin for a particular hour of the day. Only hours for which the fans are on are counted in this plot, except that hours the fans are on due to NIGHT-CYCLE-CTRL are not counted.
- SS-O TEMPERATURE SCATTER PLOT
In this scatter plot the vertical axis, at the left, shows temperature bins. The horizontal axis, at the top, gives hours of the day in local standard time, where "1AM" is midnight to 1:00am, "2" is 1:00am to 2:00am, etc. Entered in each cell of the plot is the number of hours during the run period for which the zone air temperature was in the particular bin for the particular hour of the day. Only hours for which the fans are on are counted in this plot, except that hours the fans are on due to NIGHT-CYCLE-CTRL are not counted.
- SS-P LOAD, ENERGY AND PART LOAD HEATING IN <zone name>
LOAD, ENERGY AND PART LOAD COOLING IN <system name>
Two SS-P reports are produced for each unit or system: one for heating operation and one for cooling operation. These reports are provided for: each PSZ, PVAVS, RESYS, RESVVT, or PTAC system if SS-H is requested; each zone in a PTAC or HP system if either SS-H or SS-L is requested.

Summarized are the unit loads, power, fuel, and fan energy input as well as the number of hours of operation within each ten percent load bin for both fans and compressors.

SS-Q HEAT PUMP COOLING/HEATING SUMMARY FOR <system name>
Two reports, one for heating operation and one for cooling operation, are produced for each system that contains an electric heat pump, a gas heat pump or a furnace. These reports are provided for each PSZ, PVAVS, RESYS, RESVVT, and PTAC system if SS-A is requested.

Summarized are the unit loads, the operation hours, the power and fuel input, the supplemental loads and supplemental power and fuel, and the defrost energy.

SS-R ZONE PERFORMANCE SUMMARY
This report provides information on the part-load performance of VAV boxes in zones as well as to identify those zones that influence the WARMEST and COLDEST supply air reset controls.

SUPL SYSTEM SUPPLEMENTAL EVAPORATIVE OR DESICCANT COOLING FOR <system name>
This report is printed for each system that has a desiccant or evaporative cooling unit to supplement the mechanical cooling. These are systems for which the user has specified DESICCANT = LIQ-VENT-AIR-1, LIQ-VENT-AIR-2, or SOL-VENT-AIR-1; or EVAP-CL-TYPE = INDIRECT or INDIRECT-DIRECT. This report will not be printed for stand-alone desiccant or evaporative cooling systems (SYSTEM:TYPE = PTGSD or EVAP-COOL). In this case the usual SYSTEMS reports are used.

REFG REFRIGERATION EQUIPMENT SUMMARY
Gives monthly energy use for each system in which there is refrigerated case work including the components of load and power consumption for each of up to three temperature ranges and for each class of equipment in the refrigeration system.

REPORT-FREQUENCY

Allows you to control the frequency at which SYSTEMS hourly reports are printed. REPORT-FREQUENCY = HOURLY (the default) generates reports with hourly values. Also printed are summary values (minimum, maximum, total, and average) at the end of each day and month, and at the end of the run period specified in HOURLY-REPORT:REPORT-SCHEDULE. When REPORT-FREQUENCY = DAILY, the hourly data are suppressed and only summary values are printed for each day and at the end of the month and run period. Similarly, when REPORT-FREQUENCY = MONTHLY, only the summary statistics for months and the run period are printed. REPORT-FREQUENCY = YEARLY results in a single summary report covering the entire run period. Only scheduled hours are included in the summaries.

HOURLY-DATA-SAVE

Specifies the method used to save data from an hourly report written by the HVAC program. This allows post processing or data viewing using an external program; examples could be a user written program or a third party program such as Microsoft® Excel. By default the value is NO-SAVE, so no added files are created and the HOURLY-REPORT data only appears in the formatted reports on the standard output file. Other code-words cause either formatted (text) or unformatted (binary) file(s) to be created in the local (project) directory (unless re-directed using environment variable to replace the filenames below) that contain the data from hourly report(s). The data is written to these files in a continuous stream, one record per hour, with the data in the same order as specified

in the hourly report commands which is the same order that data appears in the standard output file formatted report. The data is written to the file(s) each hour any hourly report is scheduled ON. Allowed code-words are:

NO-SAVE

Do not create file(s) to save hourly report data.

BINARY

Open the data file(s) in binary mode and write the data using binary write statements. Reading these files will usually require a custom program that can read binary data files. One hourly data and two data header files are created. One data header file is binary and the other is formatted; they both contain identical records and data, just in these different formats. When using the command line version of DOE-2 the file names binary headers, binary data and text headers for the run are:

```
CECHR<num>.bin
CECDT<num>.bin
CECPRO.FMT
```

When using the DLL version of DOE-2 (as in eQUEST) the file names for the binary headers, binary data and text headers for the run are:

```
<project directory>/<project name>_HourlyDataHeaders<num>.bin
<project directory>/<project name>_HourlyData<num>.bin
<project directory>/<project name>_HourlyDataTitles.dat
```

FORMATTED

Open the data file in formatted (text) mode and write the data using formatted write statements. This type of file can easily be imported into programs such as Microsoft® Excel. One hourly data file is created with one text record per hour with the same format and order as the hourly reports on the standard output file; there are no blank or header records and all columns of data are fixed in position and separated with one or more spaces. When using the command line version of DOE-2 the file name is:

```
CEC<prog>_<num>.dat
```

When using the DLL version of DOE-2 the file name is:

```
<project directory>/<project name>_HourlyData<prog>_<num>.dat
```

In the above file names <prog> is 1 for LOADS and 2 for HVAC and <num> is, 1 for the first LOADS calc, 2 for the first HVAC calc, 3 for the second LOADS calc, so on.

THERMAL-STORAGE

This command defines all of the operating parameters of thermal storage devices. U-name is required.

TYPE

Accepts a code word which specifies the type of this component.

COLD-WATER-TANK specifies a chilled water storage tank.

HOT-WATER-TANK specifies a hot water storage tank.

CAPACITY

Specifies the net storage capacity of the of the component. For storage devices, this keyword has units of MBtu; other types of equipment have their capacity defined in terms of MBtu/hr. The default is the loop's design hourly load, multiplied by the CAPACITY-RATIO.

CAPACITY-RATIO

When CAPACITY is defaulted, accepts a numeric value that acts as a multiplier on the loop's design hourly load. The default is one hour's load.

INITIAL-CHRG

Specifies the fraction of CAPACITY that is stored at the start of the simulation.

Temperaure Limits of the Tank

CHRG-T

Specifies the temperature at which the tank is fully charged. The default for chilled and hot water tanks is the charging loop CIRCULATION-LOOP:COOL-SETPT-T and HEAT-SETPT-T respectively. During charging periods, the loop charging this tank will operate at the more extreme requirement of the charging temperature or the loop's own temperature control. For example, if the CHRG-T for a chilled water tank is specified to be 38°F, and the CIRCULATION-LOOP:COOL-SETPT-T is 44°F, then the loop will normally operate at 44°F, but will drop to 38°F when charging the tank. This reduced temperature will in turn affect the efficiency of the chillers attached to this loop, as well as the loop's thermal losses.

T-RANGE

Specifies the temperature range between the fully charged and fully discharged state. The default is the same as the CIRCULATION-LOOP:LOOP-DESIGN-DT.

BASE-T

Specifies the tank temperature at which there is no more available storage. For chilled water tanks, the default is sum of the CHRG-T plus the T-RANGE. For hot water tanks, the default is the CHRG-T minus the T-RANGE. For example, if a chilled water tank is to be charged at 40°F, and the T-RANGE is 10°F, then the BASE-T is 50°F.

Attachments to Loops

CHRG-LOOP

Accepts the U-name of the loop that charges the tank. The tank is a demander on this loop. More than one storage component may be charged from the same loop.

DCHRG-LOOP

Accepts the U-name of the loop to which the tank discharges. The tank is a supplier to this loop. Any given loop may be supplied by only one storage component. The CHRG-LOOP and DCHRG-LOOP for a storage component may be the same.

Charging and Discharging Parameters**MAX-CHRG-RATE**

Specifies the maximum rate at which the storage component can charge. The default is the design capacity of the primary equipment attached to the charging loop.

CHRG-RATE-FHOURS

Accepts the U-name of a curve that defines how the charging rate varies with the length of time the storage has already been charged. If not specified, there is no dependence. You can use this curve to approximate the performance of ice storage systems, where the maximum charging rate will drop over time as ice builds up on the heat-exchanger surface. The program calculates the hourly charging rate as:

$$Q_{\text{charge}} = \text{MAX-CHRG-RATE} * f(\text{Past Charging Hours})$$

When defining this curve, you must define the profile over the entire charging period. Serious errors may otherwise result. You can verify the charging performance using hourly reports.

CHRG-T-FHOURS

Accepts the U-name of a curve that defines how the charging temperature varies with the length of time the storage has already been charged. If specified, this curve overrides the CHRG-T. You can use this curve to approximate the performance of ice storage systems, where the charging temperature drops over time as ice builds up on the heat-exchanger surface. When defining this curve, you must define the profile over the entire charging period. Serious errors may otherwise result. You can verify the charging performance using hourly reports.

CHRG-SCH

Accepts the U-name of a schedule (TYPE=ON/OFF) that defines the available charging period. This is a mandatory entry. A flag value of 1 means the tank is requesting charging. A value of 0 means that it is not.

DELAY-CHRG-HOUR

Specifies the latest hour in the CHRG-SCH at which you would like the storage to be fully charged. There is no default. If you do not specify this value, then the tank will start charging as soon as the CHRG-SCH allows. If you specify a value, the program will look at the charge remaining in storage, compare it to the MAX-CHRG-RATE, and determine how many hours will be required to fully charge the storage. The program will delay the start of the charging mode to the time corresponding to a full charge at the DELAY-CHRG-HOUR. For example, assume that a chilled water tank takes 8 hours to fully charge, and the CHRG-SCH is defined from 10 p.m. to 6 a.m. The previous day, only half the storage was used, so that only 4 hours will be required to recharge the tank. If the DELAY-CHRG-HOUR is not specified, the tank will start charging at 10 p.m., and will be complete at 2 a.m. If the DELAY-CHRG-HOUR is specified to be 5 a.m., the tank will start charging at 1 a.m. and will be complete at 5 a.m.

Many electric utility time-of-use rates have a more favorable rate in the midnight to 6 a.m. period than they do in the 6 p.m. to midnight period. If so, then it makes sense to specify the DELAY-CHRG-HOUR to be the last hour of the most favorable rate period. Also, wet-bulb temperatures will normally be lower in the early morning hours, so that the chillers charging the storage can operate more efficiently.

MAX-DCHRG-RATE

Specifies the maximum rate at which the storage component can discharge (supply the loop). The default is the design load of the discharge loop.

DCHRG-RATE-FHOURS

Accepts the U-name of a curve that defines how the discharging rate varies with the length of time the storage has already been discharging. If not specified, there is no dependence. You can use this curve to approximate the performance of ice storage systems, where the maximum discharge rate will vary over time as ice melts from the heat-exchanger surface. The program calculates the hourly discharge rate as:

$$Q_{\text{discharge}} = \text{MAX-DCHRG-RATE} * f(\text{Past Discharging Hours})$$

When defining this curve, you must define the profile over the entire discharging period. Serious errors may otherwise result. You can verify the discharging performance using hourly reports.

Thermal Losses of the Storage Component**LOSS-COEFFICIENT**

Specifies the loss in Btu/hr-°F for the storage. The default is zero, corresponding to no losses.

LOCATION

Accepts a code-word that specifies the location of the tank:

OUTDOOR (default) specifies that the tank is outside the building. Storage losses will be based on the hourly dry-bulb temperature.

ZONE specifies that the tank is inside the building.

ZONE-NAME

When LOCATION = ZONE, accepts the U-name of the space containing the storage. Storage losses will be based on the hourly space temperature. Currently, the program does not adjust the space temperature for the storage losses.

FREEZE-T

Specifies the temperature at which the storage medium will freeze. Heat will be added as required to prevent the medium from freezing. When using the COLD-WATER-TANK to approximate ice storage, you should set this keyword to a low value, such as 0°F.

FREEZE-LOOP

For the COLD-WATER-TANK, accepts the U-name of a HW or PIPE2 loop that will heat the tank to prevent freezing. The default is no freeze protection. For a HOT-WATER-TANK the CHRG-LOOP will provide any required freeze protection.

AUX-KW

Accepts a numeric value specifying an auxiliary electrical consumption, such as for a control panel or a pump that injects fluid from an unpressurized storage tank into a pressurized loop. For an ice bin, this keyword can be used to account for the energy consumed by air compressors or other devices that agitate the storage medium.

AUX-MODE

Accepts a code-word specifying when the AUX-KW is consumed.

ALWAYS (default) indicates that the auxiliary power is consumed all hours.

WHEN-ON indicates that auxiliary power is consumed only during the hours the component is operating.

WHEN-OFF indicates that auxiliary power is consumed only during the hours the component is off.

SCHEDULED indicates that the power consumption is scheduled.

AUX-SCH

When AUX-MODE = SCHEDULED, accepts a U-name of a schedule (TYPE = FRACTION or MULTIPLIER) that varies the AUX-KW on an hourly basis.

AUX-METER

Accepts the U-name of a meter that supplies the auxiliary energy. This keyword defaults to the MASTER-METER:AUX-ELEC-METER.

COST-DATA

Accepts the U-name of a MATERIALS-COST command. This command allows you to define first costs, maintenance costs, etc. for the loop.

EQUIPMENT-REPORTS

Accepts the codewords YES or NO. When report PS-H of the PLANT-REPORTS is enabled, a report will print for this component unless this keyword is set to NO.

ZONE

Provides information on the secondary HVAC distribution system characteristics specific to a thermal zone. Information includes air flow rate (supply air, exhaust air, and outside air), space temperature setpoint, thermostat characteristics, and maximum heating and/or cooling capacity. U-name is required.

Each zone is associated with one and only one SYSTEM command, which specifies the system to which the zone belongs. This applies to conditioned zones as well as unconditioned zones and plenum zones. Note that there must be a one-to-one match-up between the zones specified here and the spaces specified in the LOADS program. That is, for each SPACE command in LOADS there will be a corresponding ZONE command to represent a physically identical portion of the building.

Example input:

```

ZONE1-1 = ZONE
  TYPE                = CONDITIONED
  SPACE               = SPACE1-1
  DESIGN-HEAT-T       = 70.
  DESIGN-COOL-T       = 76.
  HEAT-TEMP-SCH       = "The Heating Temp Sch"
  COOL-TEMP-SCH       = "The Cooling Temp Sch"
  REHEAT-DELTA-T      = 40.
  HW-LOOP              = "Heating Loop"
  OA-FLOW/PER         = 15.
  SIZING-OPTION       = ADJUST-LOADS ..

```

TYPE

Takes a code-word that identifies the zone as being a conditioned space, an unconditioned space, or a plenum. Allowed code-words are:

CONDITIONED	The zone is heated and/or cooled depending on the type of system selected.
UNCONDITIONED	The zone is neither heated nor cooled. Examples are false ceiling spaces not used as return air plenums, attics, crawl spaces and garages.
PLENUM	<p>The zone is a plenum through which return air from the conditioned zones in the system passes. If the system has SYSTEM:RETURN-AIR-PATH = PLENUM-ZONES then one more zones in the system should have TYPE = PLENUM. The program calculates the cooling/heating loads and temperatures in the plenum zones as for other zones, except that the effect of return air flow through the plenum is considered in lieu of direct air supply.</p> <p>An above-ceiling space with return air passing through ducts in the space does not qualify as a plenum. Zonal systems (UHT, UVT, IU, FC, HP, and PTAC) do not allow plenums.</p> <p>In the program a plenum may have any characteristic of a zone, including windows, people, infiltration, etc., but not electrical equipment. See "Atrium as a Return Air Plenum" in the sunspace section of the <i>DOE-2.2 Topics</i>.</p>

SPACE

Takes the U-name of a previously-defined SPACE command that describes the space that corresponds to this zone. This is a required keyword. Previously, the correspondence between SPACES in the LOADS input and ZONES in

the SYSTEMS input was specified by giving the SPACE and ZONE the same U-name. Now the SPACE and ZONE must have different U-names.

SIZING-OPTION

Takes a code-word that specifies how the size of the system equipment should be adjusted to account for temperature differences between unconditioned and conditioned spaces at start-up. Usually, SIZING-OPTION should be specified for each zone to get a more accurate air flow rate for the zone. Optionally, SIZING-OPTION could be specified only for ZONE:TYPE = CONDITIONED and could be allowed to default for ZONE:TYPE = UNCONDITIONED or PLENUM. In this case, you should still specify the DESIGN-HEAT-T and DESIGN-COOL-T for ZONE:TYPE = UNCONDITIONED or PLENUM, so that the peak heating and cooling loads of surrounding zones are appropriately modified.

Two effects that are important to the choice of SIZING-OPTION are the following:

If the LOADS calculation temperature for the zone, given by LOADS:TEMPERATURE is between the zone's ZONE:DESIGN-HEAT-T and DESIGN-COOL-T values, the peak loads will be overestimated for cooling and heating. Consequently, the calculated air flow rate for the zone will not exactly correspond to the actual air flow rate necessary to meet the heat addition rate or heat extraction rate at the peaks.

In the LOADS program, unconditioned spaces and plenums are assumed to be at constant temperature. In fact, the temperature is not constant because the temperature of an unconditioned zone is allowed to float and the temperature in a plenum is determined by the blend of return air temperatures and flow rates. As a result, there is no contribution to the peak loads of conditioned zones from interzone heat transfer with adjacent unconditioned zones.

The allowed values of SIZING-OPTION are:

FROM-LOADS	The automatic sizing of equipment to heat or cool this zone will not consider effects (1) and (2), above.
ADJUST-LOADS	The automatic sizing of equipment to heat and cool this zone will consider Effects (1) and (2), above.

If ADJUST-LOADS is specified, three adjustments to the peak heating and cooling loads will be made:

An adjustment to account for the difference between the zone's SPACE:TEMPERATURE value and the zone's ZONE:DESIGN-HEAT-T and DESIGN-COOL-T values.

A steady-state adjustment to account for thermal conduction through the interior and exterior walls of the zone.

An adjustment to infiltration loads.

MULTIPLIER

Number of zones that are identical to some specified zone and are assigned to the same system. For example, rather than describing ten identical or near-identical thermal zones, MULTIPLIER = 10 can be used on a single-zone. For a given zone, ZONE-MULTIPLIER and its corresponding SPACE:MULTIPLIER should be the same. If not specified, defaults to SPACE:MULTIPLIER

FLOOR-MULTIPLIER

Has the same meaning as SPACE:FLOOR-MULTIPLIER in the LOADS input, and defaults to its value if not specified in SYSTEMS. See description of SPACE:FLOOR-MULTIPLIER.

Airflow

The following keywords provide information on the flow of air into and out of each zone (supply air, exhaust air, and outside air).

Generally, all air quantities should be input at sea level because the program makes a correction for altitude. If you want to input air flow rates that have already been corrected for altitude you should set SITE-PARAMETERS:ALTTITUDE = 0 in LOADS.

There are four different methods of specifying a zone's supply air flow rate:

Specify ASSIGNED-FLOW,

Specify AIR-CHANGES/HR,

Specify FLOW/AREA,

Allow the program to calculate the air flow rate based on peak heating/cooling load and difference between design supply air temperature and zone temperature. This calculation occurs when neither ASSIGNED-FLOW nor AIR-CHANGES/HR nor FLOW/AREA is entered.

Zonal / Single-duct systems

The following keywords apply to zonal systems and single-duct air terminals. They also apply to the *outlet* of a dual-duct or multizone air terminal.

ASSIGNED-FLOW

Design supply air flow rate for the zone. Use either ASSIGNED-FLOW or FLOW/AREA or AIR-CHANGES/HR.

FLOW/AREA

The minimum design supply air flow rate to the zone per unit floor area. Use either ASSIGNED-FLOW or FLOW/AREA or AIR-CHANGES/HR.

AIR-CHANGES/HR

The minimum design supply air flow rate to the zone expressed as the number of times per hour that the flow rate replaces the total volume of air in the zone. Use either ASSIGNED-FLOW or FLOW/AREA or AIR-CHANGES/HR.

TERMINAL-TYPE

For single-duct variable-air volume systems, takes a code-word that specifies the type of terminal serving the zone. The same type of terminal box does not have to be used for the entire system. For example, a PIU system will typically contain a mixture of fan powered terminal boxes and regular VAV or constant-volume reheat units. Allowed code-words are:

SVAV

Regular VAV or constant-volume box. ("SVAV" stands for "Standard Variable Air Volume.")

SERIES-PIU	The fan draws air from both the secondary and primary air streams; the blower runs all the time.
PARALLEL-PIU	The fan draws air from the secondary air stream only; the blower runs intermittently.

INDUCED-AIR-ZONE

For the PIU system only, takes the U-name the zone from which the PIU zone takes its secondary air. This is a required keyword if `TERMINAL-TYPE = SERIES-PIU` or `PARALLEL-PIU`. Usually, the `INDUCED-AIR-ZONE` is a core zone served by a non-PIU terminal (zones with PIU boxes will usually be exterior zones that use heat reclaimed from the core zone. An exception would be a zone (such as a classroom) where the primary concern is air movement, not energy efficiency. In such a case, a corridor could be specified as the `INDUCED-AIR-ZONE` even though there is no heat is reclaimed from it. The program treats this situation in the same way as it does when a core plenum is at a temperature lower than the exterior zone. Caution: the `INDUCED-AIR-ZONE` should not be a zone with `ZONE:TYPE = PLENUM`.

MIN-FLOW-RATIO

Minimum allowable zone air supply flow rate, expressed as a fraction of design flow rate. Applicable to variable-volume type systems only. This keyword also appears in the `SYSTEM` command, where it is a system level keyword that applies to all zones in the system.. Here, it is a zone level keyword that applies only to this zone, allowing different `MIN-FLOW-RATIO`s for each zone. `MIN-FLOW-RATIO` can be scheduled using `ZONE:MIN-FLOW-SCH`.

If the sum of the `MIN-FLOW-RATIO`s of all the zones times the design flow rate is less than the specified outside air flow rate, there is implied 100 per cent outside air operation at, and possibly above, the zone `MIN-FLOW-RATIO`. In other words, it may be necessary for the system to operate at 100% outside air at very low airflows in order to satisfy the ventilation requirements.

If `THERMOSTAT-TYPE = REVERSE-ACTION` is not specified, zone `MIN-FLOW-RATIO` is also the flow rate fraction in the heating mode. The VAV box will modulate its airflow between the top and bottom of the cooling setpoint throttling range, and be at the minimum flow at all temperatures below the cooling throttling range. Care must be taken to specify a reasonable `MIN-FLOW-RATIO` in this case. Depending on the value of the `MIN-FLOW-RATIO`, the system may not have enough reheat capacity. Additionally, the introduction of a small amount of (low velocity) warm air at the ceiling level may cause temperature stratification problems in many buildings. To avoid this, the `THERMOSTAT-TYPE` should be `REVERSE-ACTION`, or an `HMIN-FLOW-RATIO` can be specified to establish a higher flow ratio during heating.

For dual-duct systems, `MIN-FLOW-RATIO` is the flow ratio at the outlet of the mixing box, and should be specified only if the box has a controller measuring air flow at the outlet. `HMIN-FLOW-RATIO` and `CMIN-FLOW-RATIO` specify the minimum air flows at the inlets to the mixing box (hot and cold decks, respectively). You should refer to the discussion of these keywords in the `SYSTEM` command for more information.

MIN-FLOW/AREA

Minimum air flow per square foot of floor area. An alternative way of specifying `ZONE:MIN-FLOW-RATIO`. The program will take this value, multiply by the floor area of the zone to determine the minimum air flow allowable, and divide by the peak cooling air flow to determine `MIN-FLOW-RATIO`. The `MIN-FLOW-RATIO` is then used in the hourly simulation. If you allow the program to determine the design heating air flows, the design heating air flow will be at least this value.

MIN-FLOW-SCH

Takes the U-name of a schedule of `TYPE = FRAC/DESIGN` whose values are values of minimum flow ratio. This schedule will override the specified or calculated value of `MIN-FLOW-RATIO` unless the schedule value is -999. In

this case the specified or calculated value of MIN-FLOW-RATIO, which is found on report SV-A for each zone, is used for that hour. This schedule can be used with a value of 1.0 during warmup periods and -999 for other hours to simulate VAV boxes that are fully open during warmup.

MIN-FLOW-CTRL

Allows the choice of method used to set the hourly minimum VAV box flow fraction.. If the MIN-FLOW-SCH, CMIN-FLOW-SCH or HMIN-FLOW-SCH are specified, their hourly specified values will always be used, for the appropriate VAV box minimum flow setting, unless the hourly scheduled value is -999 even if MIN-FLOW-CTRL is specified.

- FIXED/SCHEDULED** (Default) This codeword instructs the program to model VAV boxes as having a fixed or scheduled minimum. A fixed minimum is used unless a minimum flow fraction schedule is specified through the use of MIN-FLOW-SCH, CMIN-FLOW-SCH or HMIN-FLOW-SCH.
- DCV-RESET-UP/DOWN** This codeword instructs the program to model VAV boxes that have their minimum flow fraction reset either upwards (raised) or downwards (lowered) due to demand controlled ventilation determined zone minimum OA flow rate requirements. The program calculates the zone minimum OA requirement and sets the zone VAV box minimum damper position hourly. Each zone OA requirement is calculated based upon the hourly maximum of either OA-CFM/PER (times the NUMBER-OF-PEOPLE adjusted by the hourly PEOPLE-SCHEDULE) or a minimum OA ventilation rate. The zone minimum OA ventilation rate is either MIN-OUTSIDE-AIR if specified or the maximum of OA-CHANGES (times the zone VOLUME/60), OA-FLOW/AREA (times the zone AREA.)
- DCV-RESET-UP** This codeword instructs the program to model VAV boxes that have their minimum flow fraction reset upwards (raised) due to demand controlled ventilation determined zone minimum OA flow rate requirements. The program calculates the zone minimum OA requirement and sets the zone VAV box minimum damper position upwards hourly if that is necessary; other wise the minimum is set at the design value. Each zone OA requirement is calculated based upon the hourly maximum of either OA-CFM/PER (times the NUMBER-OF-PEOPLE adjusted by the hourly PEOPLE-SCHEDULE) or a minimum OA ventilation rate. The zone minimum OA ventilation rate is either MIN-OUTSIDE-AIR if specified or the maximum of OA-CHANGES (times the zone VOLUME/60), OA-FLOW/AREA (times the zone AREA.)
- DCV-RESET-DOWN** This codeword instructs the program to model VAV boxes that have their minimum flow fraction reset downwards (lowered) due to demand controlled ventilation determined zone minimum OA flow rate requirements. The program calculates the zone minimum OA requirement and sets the zone VAV box minimum damper position downwards hourly if that is necessary; other wise the minimum is set at the design value. Each zone OA requirement is calculated based upon the hourly maximum of either OA-CFM/PER (times the NUMBER-OF-PEOPLE adjusted by the hourly PEOPLE-SCHEDULE) or a minimum OA ventilation rate. The zone minimum OA ventilation rate is either MIN-OUTSIDE-AIR if specified or the maximum of OA-CHANGES (times the zone VOLUME/60), OA-FLOW/AREA (times the zone AREA.)

Dual-duct systems

The following keywords apply to the *inlets* of a dual-duct or multizone air terminal. Similar keywords apply to the *outlet* of the same terminal, and are described above.

CMIN-FLOW-RATIO

For dual-duct and multizone systems, this is the minimum air flow ratio of the controller that modulates the cold duct damper at the inlet of the mixing box. See SYSTEM:CMIN-FLOW-RATIO for more information. This keyword defaults to the value specified for the system.

CMIN-FLOW/AREA

Minimum cooling air flow per unit floor area. An alternative way of specifying ZONE:CMIN-FLOW-RATIO. If you allow the program to determine the zone design cooling air flows, the zone design cooling air flow will be at least this value if CMIN-FLOW-RATIO has not been specified.

CMIN-FLOW-SCH

Takes the U-name of a schedule (with TYPE = FRAC/DESIGN) of hourly values of CMIN-FLOW-RATIO. See SYSTEM:CMIN-FLOW-RATIO for more information.

HFLOW/AREA

Similar to FLOW/AREA. If specified, the maximum heating air flow for the mixing box will be set to this value if it results in a larger than HAIR-CHANGES/HR and HASSIGNED-FLOW has not been specified.

HAIR-CHANGES/HR

Similar to AIR-CHANGES/HR. If specified, the maximum heating air flow for the mixing box will be set to this value if it results in a larger value than HFLOW/AREA and HASSIGNED-FLOW has not been specified.

HASSIGNED-FLOW

Similar to ASSIGNED-FLOW. If specified, the maximum heating air flow for the mixing box will be set to this value.

HMIN-FLOW-RATIO

Minimum hot duct air flow ratio. Intended primarily for dual-duct and multizone systems but also has a special meaning for single-duct VAV systems. Does at the zone level what SYSTEM:HMIN-FLOW-RATIO does at the system level. See SYSTEM:HMIN-FLOW-RATIO for a complete description. Defaults to the value specified for the system.

HMIN-FLOW/AREA

Minimum heating air flow per unit floor area. An alternative way of specifying ZONE:HMIN-FLOW-RATIO. If you allow the program to determine the zone design heating air flows, the zone design heating air flow will be at least this value if HMIN-FLOW-RATIO has not been specified.

HMIN-FLOW-SCH

Takes the U-name of a schedule (with TYPE = FRAC/DESIGN) of hourly values of HMIN-FLOW-RATIO.

MIN-FLOW-SOURCE

For a dual-duct or multizone system, takes a code-word that specifies the source of the makeup air used by the outlet controller when the total supply air flow falls below ZONE:MIN-FLOW-RATIO. See SYSTEM:MIN-FLOW-SOURCE for a complete description. Defaults to the value specified for the system.

COLD-DUCT	Causes the makeup air to be drawn from the cold duct.
HOT-DUCT	Causes the makeup air to be drawn from the hot duct.

SNAP-ACTING Causes the makeup air to be drawn from the hot duct during the heating mode and from the cold duct during the cooling mode. When in the deadband, the makeup air is drawn from whichever duct was last active. Note that a snap-acting controller, together with a large ZONE:MIN-FLOW-RATIO, may cause the zone temperature to oscillate back and forth between the heating and cooling setpoints

Outside-Air Ventilation

The following keywords describe the outside air ventilation requirements of a zone. If specified, these keywords take precedence over specifying outside air at the SYSTEM level.

OA-FLOW/PER

Minimum flow rate of outside ventilation air per person at peak occupancy. OUTSIDE-AIR-FLOW, described below, takes precedence over this input. Although the specified quantities may be modified by the program for the sake of consistency, the flow of outside ventilation air is an uninterrupted flow as long as the fans are operating. The outside ventilation air quantity is not determined by the design space heating or cooling demands except when an economizer is specified. Use either OUTSIDE-AIR-FLOW or OA-FLOW/PER or OA-CHANGES.

OA-CHANGES

Minimum flow rate of outside ventilation air for the zone expressed in terms of the number of times per hour that this flow rate would replace the total volume of air in the zone. OUTSIDE-AIR-FLOW, described below, takes precedence over this input. Although the specified quantities may be modified by the program for the sake of consistency, the flow of outside ventilation air is an uninterrupted flow as long as the fans are operating. The outside ventilation air quantity is not determined by the design space heating or cooling demands except when an economizer is specified. Use either OUTSIDE-AIR-FLOW or OA-FLOW/PER or OA-CHANGES.

OUTSIDE-AIR-FLOW

The minimum flow rate of outside ventilation air for the zone. Alternatively, or additionally, outside air flow rate may be specified by the keywords OA-FLOW/PER and OA-CHANGES (or by SYSTEM:MIN-OUTSIDE-AIR). The program calculates outside air flow rate based on each entry and normally uses the larger value except if it sees data entry for OUTSIDE-AIR-FLOW, which overrides other values. Note that specifying outside ventilation air at the zone level takes precedence over specifying it at the system level. Although the specified quantities may be modified by the program for the sake of consistency, the flow of outside ventilation air is an uninterrupted flow as long as the fans are operating. The outside ventilation air quantity is not determined by the design space heating or cooling demands except when an economizer is specified. Use either OUTSIDE-AIR-FLOW or OA-FLOW/PER or OA-CHANGES.

OA-FLOW/AREA

This keyword allows the specification of a minimum zone outside air (OA) flow rate per unit of zone floor area. The use of OUTSIDE-AIR-FLOW will over ride the value of this keyword. The maximum of values resulting from OA-FLOW/AREA, OA-FLOW/PER, and OA-CHANGES will be used unless an over-ride value for OUTSIDE-AIR-FLOW is specified.

Zone Fans

The following keywords apply only to the circulating air fans of powered induction units (SYSTEM:TYPE = PIU).

ZONE-FAN-RATIO

ZONE-FAN-RATIO times the design primary air flow rate gives design flow rate of the PIU fan for ZONE:TERMINAL-TYPE = SERIES-PIU or PARALLEL-PIU. If both ZONE-FAN-FLOW and ZONE-FAN-RATIO are specified, ZONE-FAN-FLOW takes precedence. Defaults to 1.0 for ZONE:TERMINAL-

TYPE = SERIES-PIU. There is no default for ZONE:TERMINAL-TYPE = PARALLEL-PIU; in this case, ZONE-FAN-RATIO or ZONE-FAN-FLOW must be input.

ZONE-FAN-FLOW

The design capacity of the PIU fan. If TERMINAL-TYPE = SERIES-PIU or PARALLEL-PIU, you can size the fan with this keyword. If neither ZONE-FAN-RATIO nor ZONE-FAN-FLOW is specified, the program will size the fan. For ZONE:TERMINAL-TYPE = SERIES-PIU this is a straightforward process: The blower is sized to the maximum flow rate determined from ZONE-AIR:ASSIGNED-FLOW, AIR-CHANGES/HR or FLOW/AREA, or it is sized by the program from design-day peak heating and cooling loads. For ZONE:TERMINAL-TYPE = PARALLEL-PIU, if ZONE-FAN-FLOW is not input, the blower is sized from the heating peak. The ZONE-level air flow keywords are assumed to refer to the primary air from the central system. It is recommended that you explicitly size the fans, since the use of the heating peak to size the parallel PIU might result in a ridiculously small fan.

ZONE-FAN-KW/FLOW

The power of the fan per unit flow rate for ZONE:TERMINAL-TYPE = SERIES PIU or PARALLEL-PIU.

ZONE-FAN-T-SCH

Required if ZONE:TERMINAL-TYPE = PARALLEL-PIU. Takes the U-name of a schedule (TYPE = TEMPERATURE) that gives the zone temperature at which the terminal blower turns on. This temperature must be above the heating range.

Exhaust Airflow and Fans

This set of keywords defines exhaust at the zonal level. If zonal exhaust requires more outside air than specified for ventilation, exhaust will take precedence.

EXHAUST-FLOW

Flow rate of the zone's exhaust fan. This entry can be omitted if there is no exhaust from the zone, if there is only central exhaust by way of the system return, or if the exhaust tracks the supply flow (see AIRFLOW-TRACKING). If specified, EXHAUST-STATIC should also be entered. The exhaust fan may be either constant flow or variable flow. It is assumed to operate only when the system supply and return fans operate (see SYSTEM:FAN-SCHEDULE or SYSTEM:EXHAUST-FAN-SCH).

The SYSTEMS program simulates heat recovery from central exhaust only, not from zone exhaust. If heat is to be recovered, zone exhaust should not be entered but rather allowed to default to the central system. Return fan static should be adjusted, on a weighted average basis, to reflect zone exhaust fan conditions.

The program will not allow SYSTEM:MIN-OUTSIDE-AIR to be less than the sum of EXHAUST-FLOWs for all zones divided by the sum of supply flows for all zones. That is, MIN-OUTSIDE-AIR will not restrict the operation of exhaust fans.

EXHAUST-KW/FLOW

The electrical power of the zone's exhaust fan per unit air flow. An alternative to specifying EXHAUST-STATIC and EXHAUST EFF, described below.

EXHAUST-STATIC

Total pressure produced by the zone's exhaust fan.

EXHAUST-EFF

Combined efficiency of the zone exhaust fan and motor at design conditions. Applies only if EXHAUST-FLOW is specified. The program calculates exhaust fan power from EXHAUST-EFF, EXHAUST-FLOW and EXHAUST-STATIC.

EXHAUST-FAN-CTRL

Takes a code-word that specifies the type of exhaust airflow reduction control. The program calculates the part-load power consumption of the exhaust fan using the fan power vs. part load characteristics corresponding to the control mode selected (Figure 37). Allowed code words are:

CONSTANT-VOLUME	No airflow control; the exhaust fan runs at constant flow all hours it is enabled. If the exhaust flow from the zone is variable (as defined by the EXHAUST-FAN-SCH), but the EXHAUST-FAN-CTRL = CONSTANT-VOLUME, then an outdoor-air makeup is assumed at the inlet to the fan, so that the fan discharge is constant volume. This configuration can be used to simulate a variable-flow fume hood in the zone, and a constant-velocity discharge on the roof; typical of many laboratories.
SPEED	Control is by varying motor speed (Curve 1 in Figure 37). If specified, then the EXHAUST-FAN-SCH must also be specified.
INLET	Control is by varying the position of inlet vanes. If specified, then the EXHAUST-FAN-SCH must also be specified.
DISCHARGE	Control is by varying the position of discharge dampers or allowing the duct pressure to build behind the VAV box (Curve 3 in Figure 37). If specified, then the EXHAUST-FAN-SCH must also be specified.
CYCLING	Control is by cycling the fans on and off (Curve 4 in Figure 37). If specified, then the EXHAUST-FAN-SCH must also be specified.
FAN-EIR-FPLR	Fan control method is user specified using the U-name of a curve as input to FAN-EIR-FPLR. See description of FAN-EIR-FPLR. If specified, then the EXHAUST-FAN-SCH must also be specified.

If the zone's airhandler cycles during the hour, then the exhaust fan will also cycle. Fan power is calculated based on the scheduled airflow, and then reduced by the fraction of the hour the fan is cycled off. .

EXHAUST-EIR-FPLR

When EXHAUST-FAN-CTRL = FAN-EIR-FPLR, takes the U-name of a linear, quadratic, or cubic curve that gives the ratio of exhaust fan electric energy to full-load fan electric energy, as a function of airflow.

EXHAUST-FAN-SCH

Accepts U-name of a schedule (TYPE = ON/OFF or FRACTION) that specifies the hours of operation of the zonal exhaust fan. A zero value indicates that the exhaust fan is off. A non-zero value indicates the exhaust is on. A fractional value between zero and one indicates that the exhaust is variable, such as for a kitchen hood or a laboratory fume hood.

The exhaust fans can only operate when the main fans are on (FAN-SCHEDULE is positive). If the zonal EXHAUST-FAN-SCH is not specified, it defaults to its parent SYSTEM:EXHAUST-FAN-SCH; otherwise operation is the same as the SYSTEM:FAN-SCHEDULE.

If the zone's airhandler cycles during the hour, then the exhaust fan will also cycle. The hourly fan airflow will be reduced by the amount of time the air handler is cycled off. This is in addition to any modulation specified by the EXHAUST-FAN-SCH.

AIRFLOW-TRACKING

Specifies whether and how the exhaust flow is tracked and coordinated with the supply flow. Acceptable code-words are:

- NONE** The exhaust flow is not coordinated with the supply airflow; other than design parameters. The design supply airflow will be at least the exhaust flow. For a VAV terminal, the default ZONE:MIN-FLOW-RATIO will be based on the greater of the ventilation air requirement or the maximum EXHAUST-FLOW.
- TRACK-EXHAUST** Indicates that a VAV terminal will track the hourly exhaust flow. Each hour, the VAV terminal flow will be the greater of the exhaust flow, the requirement for space conditioning, or the flow corresponding to the MIN-FLOW-RATIO. Normally, the EXHAUST-FAN-SCH will be specified to simulate variable-flow exhaust.
- The default ZONE:MIN-FLOW-RATIO will be based on the ventilation air requirement only; the peak exhaust flow will be ignored. However, the peak exhaust flow will be taken into account in sizing the terminal reheat coil.
- This mode may be used to simulate a laboratory fume hood where the supply airflow to the space is modulated as the hood's sash is raised and lowered. If the space temperature requires a supply airflow greater than the exhaust, then the non-exhausted supply will be returned to the air handler. To exhaust all of the supply, specify TRACK-BOTH.
- TRACK-SUPPLY** The exhaust flow will modulate to exactly match the supply air flow. In this mode, the EXHAUST-FLOW is not specified or controlled independently of the supply. Instead, the peak exhaust flow is set the same as the peak supply, and the hourly exhaust flow is the same as the supply hourly.
- The default ZONE:MIN-FLOW-RATIO will be based on the ventilation air requirement only; the peak exhaust flow will be ignored.
- This mode may be used to simulate a variable-volume space that does not have fume hoods or other specific exhaust needs, but where none of the supply is allowed to return to the air handler.
- TRACK-BOTH** Both the hourly exhaust flow and the supply flow are tracked, and both are set to the greater of the two. The peak exhaust flow is not specified, but instead is the same as the peak supply. The hourly exhaust flow is set by the EXHAUST-FAN-SCH, and the supply according to the space conditioning requirements. If the exhaust is less than the supply, then the exhaust is increased to match the supply. If the supply is less than the exhaust, then the supply is increased to match the exhaust.
- The default ZONE:MIN-FLOW-RATIO will be based on the ventilation air requirement only; the peak exhaust flow will be ignored.

This mode is useful in simulating a laboratory with variable-flow fume hoods, where no supply should return to the air handler. If the exhaust hood airflow drops below the supply flow, then an auxiliary exhaust damper modulates to remove the excess supply. If instead the fume hoods are exhausting more than the supply needed for space conditioning, then the supply will open to match the exhaust. Reheat may then be required to maintain space temperature.

Cooling Equipment / Sizing

DESIGN-COOL-T

The space temperature that the program uses to calculate the supply air flow rate required to meet design-day cooling loads for the zone. Required for all conditioned zones (ZONE:TYPE = CONDITIONED). May also be specified for unconditioned or plenum zones (ZONE:TYPE = UNCONDITIONED or PLENUM). In this case, the value should be the predicted zone temperature at the time of peak cooling in adjacent zones, i.e., in those surrounding zones that share an interior wall with this zone. If ZONE:TYPE = UNCONDITIONED or PLENUM and no value is specified for DESIGN-COOL-T, it will default to the LOADS calculation temperature (SPACE:TEMPERATURE) for the space corresponding to this zone. DESIGN-COOL-T is a required keyword for the stand-alone evaporative cooler (SYSTEM:TYPE = EVAP-COOL).

MAX-COOL-RATE

Design maximum net heat extraction rate of the air system for the zone. If entered it will override program-calculated capacity based on design day loads. MAX-COOL-RATE can be used to suppress the cooling capability of a zone by entering very low value (e.g., 1.0). In this case the zone air flow will be calculated on the basis of heating only, rather than on the larger of the cooling and heating requirements. This value is defaulted from the load calculation peak zone total sensible cooling value.

COOLING-CAPACITY

Total cooling capacity (sensible + latent) at ARI rated conditions of either the zonal cooling coil or the zonal cooling system, depending on which is being specified. When specifying COOLING-CAPACITY for packaged DX cooling units with draw-through fans, SUPPLY-EFF and SUPPLY-STATIC should be omitted and SUPPLY-DELTA-T should be set to zero if the COOLING-CAPACITY includes cooling of the fan motor. Otherwise, double counting of supply fan motor heat will occur. For better latent simulation, SUPPLY-DELTA-T should be specified and the COOLING-CAPACITY adjusted to correspond to the unit without the fan. The program-designed COOLING-CAPACITY (for DX systems) is at ARI rated conditions and fan power and heat are not included.

This keyword is appropriate only to "zonal systems" (UHT, UVT, FC, HP, and PTAC). It is usually specified at the system level, but for zonal systems it also appears at the zone level. For IU systems this is the design heating capacity of the coil in the zone induction box. If not input the program will calculate the cooling capacity at ARI conditions. The program will adjust the cooling capacity at non-ARI conditions using default performance curves unless you specify your own performance curves.

COOL-SH-CAP

The sensible heat removal capacity of the zonal air cooling device at ARI rated conditions. At non-ARI rated conditions, the value will be corrected for entering wet-bulb temperature and outdoor dry-bulb temperature (or entering water temperature for an HP system). The sensible capacity is always less than or equal to the total capacity.

This keyword is appropriate only to the "zonal systems" (UHT, UVT, FC, HP, and PTAC). It is usually specified at the system level, but for zonal systems it also appears at the zone level. For IU systems this value is not used; the COOLING-CAPACITY is assumed to be 100% sensible (dry coil is assumed.) If not input the program will calculate its value at ARI conditions. The program will adjust its value at non-ARI conditions using default performance curves unless you specify your own performance curves.

NO	The unit does not have an isolation valve; full flow occurs whenever the loop pump is active.
YES	The unit has an isolation valve that shuts off loop flow through the unit when the unit's compressor is off.

WSE-LOOP

Accepts a U-name of the CIRCULATION-LOOP to which the water-side economizer coil is attached. The economizer will normally be attached to the same loop as the condenser, although they may be attached to different loops. Acceptable loop types are CW and WLHP. If not specified at the zonal level, this keyword's value is taken from the same keyword at the system level.

WSE-COIL-DT

For systems utilizing a zonal water-side economizer, specifies the temperature change through the coil at the coil design conditions. This value is used, together with the design load and loop fluid characteristics, to determine the design coil flow. If not specified at the zonal level, this keyword's value is taken from the same keyword at the system level.

WSE-VALVE-TYPE

For systems utilizing a zonal water-side economizer, accepts a code-word which specifies the type of valve coil. If not specified at the zonal level, this keyword's value is taken from the same keyword at the system level.

TWO-WAY	indicates a valve which will vary the flow through the coil and loop as the load varies.
THREE-WAY	indicates a valve that will vary the flow through the coil as the load varies, but that bypasses the remainder of the design flow around the coil so that the loop flow remains constant.

WSE-COIL-HEAD

For systems utilizing a zonal water-side economizer, accepts a numeric value which specifies the pressure drop through the coil of the loop fluid at the design flowrate. This value should include the friction losses of the coil's control valve, trim, and any piping associated with the coil and not included in the pressure drop of the loop which serves this coil. If not specified at the zonal level, this keyword's value is taken from the same keyword at the system level.

Heating Equipment / Sizing**DESIGN-HEAT-T**

The space temperature that the program uses to calculate the supply air flow rate required to meet design-day heating loads for the zone. Required for all conditioned zones (ZONE:TYPE = CONDITIONED). May also be specified for unconditioned or plenum zones (ZONE:TYPE = UNCONDITIONED or PLENUM). In this case, the value should be the predicted zone temperature at the time of peak heating in adjacent zones, i.e., in those surrounding zones that share an interior wall with this zone. If ZONE:TYPE = UNCONDITIONED or PLENUM and no value is specified for DESIGN-HEAT-T, it will default to the LOADS calculation temperature (SPACE:TEMPERATURE) for the space corresponding to this zone. DESIGN-HEAT-T is a required keyword for the stand-alone evaporative cooler (SYSTEM:TYPE = EVAP-COOL).

MAX-HEAT-RATE

Design net heat addition rate from the air system for the zone. Note that the input is a negative number. Does not include the baseboard heat addition rate. If MAX-HEAT-RATE is entered it will override program-calculated

capacity based on design day loads. MAX-HEAT-RATE can be used to suppress the heating capability of a zone. This value is defaulted from the load calculation peak space total heating value.

HEATING-CAPACITY

Total capacity of the zonal heating system. For HP and PTAC systems this is at ARI conditions. Note that the input is a negative value; if the minus sign is omitted, an error will occur. The program-calculated heating capacity does not include fan power and heat, if specified separately (see COOLING-CAPACITY).

This keyword is appropriate only to "zonal systems" (UHT, UVT, FC, HP, and PTAC). It is usually specified at the system level, but for zonal systems it also appears at the zone level. For IU systems this is the design heating capacity of the coil in the zone induction box. If not input the program will calculate the heating capacity at ARI conditions. The program will adjust the heating capacity at non-ARI conditions using default performance curves unless you specify your own performance curves.

REHEAT-DELTA-T

For the PIU system only, the maximum increase in temperature for supply air passing through the zone reheat coil. This is a required keyword for zones in a PIU system. For other system types, REHEAT-DELTA-T must be specified at the SYSTEM level

HW-LOOP

Takes the U-name of the loop (of type HW, PIPE2 or STM) to which the hot water coil in this zone is connected. If not specified at the zonal level, this keyword's value is taken from the ZONE-HW-LOOP keyword in the SYSTEM command for this zone.

HW-COIL-DT

For systems utilizing a zonal hot-water loop, the temperature change through the zone heating coil at design conditions. This value is used, together with the design load and loop fluid characteristics, to determine the design coil flow. If not specified at the zonal level, this keyword's value is taken from the same keyword at the system level.

HW-VALVE-TYPE

For systems utilizing a zonal hot-water loop, takes a code-word that specifies the type of valve used on hot water coils in the system. Applies to all hot water valves in the system, including main heating coil, preheat, reheat, zonal, and baseboards. Different systems may have different types of valves. If not specified at the zonal level, this keyword's value is taken from the same keyword at the system level.

TWO-WAY

As the load varies, the valve throttles the flow through the coil and loop to maintain the leaving air temperature. No water is bypassed.

THREE-WAY

As the load varies, some of the flow is bypassed around the coil to maintain the leaving air temperature. The loop flow remains constant.

HW-COIL-HEAD

For systems utilizing a zonal hot-water loop, the fluid pressure drop through the hot water coil at the design flow rate. This value should include the friction losses of the coil's control valve, trim, and any piping associated with the coil and not included in the pressure drop of the loop that serves this coil. If not specified at the zonal level, this keyword's value is taken from the same keyword at the system level.

DHW-LOOP

When HEAT-SOURCE = DHW-LOOP, accepts the U-name of the domestic hot water loop that provides heat energy to this heating coil. Sometimes apartments or homes in mild climates do not require significant heating. It is sometimes more economical to increase the size of the domestic water heater and use it for space heating as well as domestic hot water.

Baseboard Heating**BASEBOARD-RATING**

Accepts a value that represents the full load heating (negative number) capacity, in Btu, of the baseboards in the ZONE. Default is calculated using the SPACE heating peak calculated by the LOADS program (subject to the calculations resulting from SIZING-OPTION = ADJUST-LOADS) or entered using the MAX-HEAT-RATE keyword. If a heating capacity is specified (by appropriate use of HEATING-CAPACITY, MAX-SUPPLY-T, or REHEAT-DELTA-T keywords) the baseboard capacity is reduced to account for this lower capacity requirement. If added capacity is required due to cold air from an air system (such as central cooling systems like VAV, PIU, IU, etc.) than the baseboard sizing calculation attempts to take this requirement into account.

BASEBOARD-CTRL

Takes a code-word that specifies the control method for baseboard heating in the zone. Defines the control method as THERMOSTATIC using HEAT-TEMP-SCH as the setpoints, or OUTDOOR-RESET to allow BASEBOARD-SCH reset control. This is a zone-level keyword for PLENUM-type zones; it allows "baseboards" to be placed in plenums and allows the simulation of outside or space temperature controlled heaters in the return air space. The plenum heater is activated based on outside air temperature and reset schedule when it is outside controlled. When it is space temperature controlled, and if the interaction with the return air does not result in a temperature above the scheduled value, the heater is turned on. In either case, the source of energy input to the heater is defined by the specified or defaulted value for BASEBOARD-SOURCE. See also BASEBOARD-CTRL, THROTTLING-RANGE and BASEBOARD-RATING. Input for this keyword is the code-word that specifies the method used for controlling the output of the baseboard heating element in the zone.

THERMOSTATIC Baseboard heating is controlled by a thermostat located in the zone. The program assumes that the baseboards add heat as required, up to their maximum capacity, to maintain zone air temperature within the heating throttling range. If there is a heating load the baseboards are sequenced on first. If the baseboards cannot meet the entire heating load, heating from the zone's air system, if available, will then be activated.

OUTDOOR-RESET Baseboard heating is controlled by a thermostat located outside the building. In this case the program assumes that the baseboard heating output increases linearly as the outside air temperature decreases. The linear function and the operating period are defined by SYSTEM:BASEBOARD-SCH.

BBRD-LOOP

Accepts a code-word which specifies the U-name of the loop to which the baseboard coil in this zone is connected. Acceptable loop types are HW and PIPE-2. If not specified at the zonal level, this keyword's value is taken from the ZONE-HW-LOOP keyword at the system level.

BBRD-COIL-DT

For systems utilizing a zonal baseboard loop, specifies the temperature change through the coil at the coil design conditions. This value is used, together with the design load and loop fluid characteristics, to determine the design coil flow. If not specified at the zonal level, this keyword's value is taken from the same keyword at the system level.

BBRD-VALVE-TYPE

For systems utilizing a zonal baseboard loop, accepts a code-word which specifies the type of coil valve.

TWO-WAY As the load varies, the valve throttles the flow through the coil and loop to maintain the leaving air temperature. No water is bypassed.

THREE-WAY As the load varies, some of the flow is bypassed around the coil to maintain the leaving air temperature. The loop flow remains constant.

BBRD-COIL-HEAD

For systems utilizing a zonal baseboard loop, accepts a numeric value which specifies the pressure drop through the coil of the loop fluid at the design flowrate. This value should include the friction losses of the coil's control valve, trim, and any piping associated with the coil and not included in the pressure drop of the loop which serves this coil.

Floor Panel Systems**PANEL-LOSS-RATIO**

For zones with panel heating elements, the heat loss from the panel divided by the heat added to the zone by the panel. Losses may occur from the underside or edge of the panel. You are required to estimate this ratio, which the program assumes to remain constant over the full range of panel heating output. This keyword applies only to zones equipped with panel heating elements.

Temperature Control

The following keywords provide information on zone temperature control characteristics such as set point, type of thermostat, and throttling range.

HEAT-TEMP-SCH

Takes the U-name of a schedule of TYPE = TEMPERATURE that gives the heating setpoint of the zone thermostat. If not specified, the program will assume that the zone has no zone-activated heating control. If omitted, no heating in zone. For constant volume DDS, MZS, and PMZS systems this schedule provides the value of the lower end of the heating/cooling throttling range; the COOL-TEMP-SCH provides the value of the upper limit of the range.

This keyword can be used for PLENUM-type zones; it allows "baseboards" to be placed in plenums and allows the simulation of outside or space temperature controlled heaters in the return air space. The plenum heater is activated based on outside air temperature and a reset schedule when it is outside temperature controlled. When it is space temperature controlled, and if the interaction with the return air does not result in a temperature above the scheduled value, the heater is turned on. In either case, the source of energy input to the heater is defined by the specified or defaulted value for BASEBOARD-SOURCE. See also BASEBOARD-CTRL, THROTTLING-RANGE and BASEBOARD-RATING. This is a required keyword for the stand-alone evaporative cooler.

COOL-TEMP-SCH

Takes the U-name of a schedule of TYPE = TEMPERATURE that gives the cooling setpoint of the zone thermostat. If not specified, the program will assume that the zone has no zone-activated cooling control. If omitted, no cooling in zone. For constant volume DDS, MZS, and PMZS systems this schedule provides the value of the upper end of the heating/cooling throttling range; the HEAT-TEMP-SCH provides the value of the lower limit of the range.

THERMOSTAT-TYPE

Takes a code-word that specifies the type of thermostat used to control the zone temperature. The program assumes the same type of thermostat action for both cooling and heating. In the following the zone heating setpoint is given by HEAT-TEMP-SCH, the cooling setpoint is given COOL-TEMP-SCH and the thermostat throttling range is given by THROTTLING-RANGE. Allowed code-words are:

PROPORTIONAL	The heat addition rate (or heat extraction rate) is throttled in linear proportion to the difference between the zone set point temperature and the actual zone temperature.
TWO-POSITION	Heating is fully on when the zone temperature is below the heating setpoint, cooling is fully on when the zone temperature is above the cooling setpoint, and

there is neither heating nor cooling when the zone temperature is between the heating and cooling setpoints. This code-word is usually not used for hot and chilled water system controls. The program ignores this selection if inappropriate for a particular system type.

REVERSE-ACTION

Similar to PROPORTIONAL except that the thermostat reverses its signal on a request for heating. Most often used on dual-duct VAV systems. In VAV systems it allows the air flow rate to go above the design minimum flow for heating, as defined by SYSTEM:MIN-FLOW-RATIO. Otherwise, the effect is the same as for PROPORTIONAL.

The default value for THERMOSTAT-TYPE varies by system type and by how the system is used:

MZS, DDS and PMZS systems: The default is PROPORTIONAL for constant-flow mixing boxes and REVERSE-ACTION for others. This allows the hot deck to pass the same maximum air flow as the cold deck. Otherwise, the hot deck side of the box will be sized to the heating load.

Constant-volume systems: If HEAT-SOURCE = HOT-WATER the program assumes the heating valve can modulate output and the thermostat type defaults to PROPORTIONAL. Otherwise, it is TWO-POSITION.

Variable-volume systems: Normally, the thermostat type defaults to PROPORTIONAL. However, if SYSTEM:MIN-FLOW-RATIO is less than 0.4, and SYSTEM:HMIN-FLOW-RATIO is not specified, then a REVERSE-ACTION thermostat is assumed. Otherwise, temperature stratification problems might arise when attempting to heat a space with a small volume of air.

THROTTLING-RANGE

The number of degrees that room temperature must change in order to go from full heating to zero heating or from full cooling to zero cooling. The zone temperature heating or cooling set point is assumed to be at the midpoint of the throttling range. This keyword is appropriate to THERMOSTAT-TYPE = PROPORTIONAL or REVERSE-ACTION only.

THROTTLING-RANGE is also used by the program to determine the number of hours that a zone is undercooled or underheated (see Systems Report SS-F). If the zone temperature is more than one THROTTLING-RANGE above the cooling set point, the zone for that hour is considered to be undercooled. Likewise, if the zone temperature is more than one THROTTLING-RANGE below the heating set point, the zone for that hour is considered to be underheated.

The default value of THROTTLING-RANGE is 2.0F (1.1K) if THERMOSTAT-TYPE = PROPORTIONAL or REVERSE-ACTION, and is 0.5F (0.28K) if THERMOSTAT-TYPE = TWO-POSITION.

Sunspaces

The following keywords provide information for a zone that also serves as a sunspace.

SS-FLOW-T-SCH

Used only for sunspace zones (i.e., those with ZONE:SUNSPACE = YES) to prevent warm air from a sunspace from overheating the adjacent zone. Takes the U-name of a schedule of TYPE = TEMPERATURE. The air flow, forced or natural, from the sunspace to the adjacent space is turned off if $T(\text{zone adjacent to sunspace}) > \text{SS-FLOW-T-SCH}$ value.

Note that if SS-FLOW-SCH or SS FLOW-T-SCH is defined for a non-sunspace (ZONE:SUNSPACE = NO), it will be ignored.

This keyword modifies the flow of air across an INTERIOR-WALL between a sunspace and an adjoining zone, as determined by the AIR-FLOW-RATE, AIR-FLOW-CTRL-DT, AIR-FLOW-TYPE, etc. parameters for the wall (see INTERIOR-WALL:WALL-PARAMETERS).

SS-FLOW-SCH

Used only for sunspace zones (i.e., those with ZONE:SUNSPACE = YES). Takes the U-name of a schedule (TYPE = FRACTION), with values between 0 and 1 that multiply the air flow across an INTERIOR-WALL between a sunspace and an adjacent zone. This schedule could be used, for example, to turn off flow at night or during the summer months. If SS-FLOW-SCH is not specified for a sunspace, the flow multiplier defaults to 1.0, and so has no effect.

This keyword modifies the flow of air across an INTERIOR-WALL between a sunspace and an adjoining zone, as determined by the AIR-FLOW-RATE, AIR-FLOW-CTRL-DT, AIR-FLOW-TYPE, etc. parameters for the wall (see INTERIOR-WALL:WALL-PARAMETERS).

Sunspace Venting

The following seven keywords can be used to control venting of a sunspace with outside air.

SS-VENT-CST

Used only for sunspace zones (i.e., those with ZONE:SUNSPACE = YES). SS-VENT-CST, SS-VENT-WND and SS-VENT-TEMP are coefficients in the following expression that gives the number of outside-air changes per hour when venting the sunspace by natural convection, which is assumed to occur if the power of the venting fan is zero (SS-VENT-KW = 0):

$$\text{Venting ach} = \frac{[\text{SS-VENT-CST}] + [\text{SS-VENT-WND}] * (\text{windspeed}) + [\text{SS-VENT-TEMP}] * |T(\text{sunspace}) - T(\text{outside air})|}{1}$$

If SS-VENT-KW > 0, the venting is assumed to be fan-forced at a constant air change rate given by SS-VENT-CST. In this case, SS-VENT-WND and SS-VENT-TEMP are ignored.

SS-VENT-WND

See description of SS-VENT-CST.

SS-VENT-TEMP

See description of SS-VENT-CST.

SS-VENT-T-SCH

Used only for sunspace zones (i.e., those with ZONE:SUNSPACE = YES). Takes the U-name of a schedule (TYPE = TEMPERATURE) of sunspace air temperatures above which venting will occur if the outside air temperature is low enough. If T(vent) is the value of SS-VENT-T-SCH, venting will take place if all of the following are true:

$$T(\text{sunspace}) > T(\text{vent})$$

$$T(\text{outside air}) < \text{SS-VENT-LIMIT-T}$$

$$T(\text{outside air}) < T(\text{sunspace})$$

SS-VENT-SCH value = 1

The venting temperature is input as a schedule in order to allow seasonal variation. For example, the venting temperature might be set higher in the winter to increase the amount of heat convected or conducted from the sunspace to adjacent rooms.

SS-VENT-SCH

Used only for sunspace zones (i.e., those with ZONE:SUNSPACE = YES). Takes the U-name of a schedule of TYPE = ON/OFF that determines when a sunspace can be vented. The allowed schedule values are 0 if venting is not allowed and 1 if venting is allowed (subject to the temperature conditions described under SS-VENT-T-SCH, above). The default is no venting if this schedule is not input.

SS-VENT-LIMIT-T

Used only for sunspace zones (i.e., those with ZONE:SUNSPACE = YES). Outside dry-bulb temperature below which venting can occur (see description of SS-VENT-T-SCH, above).

SS-VENT-KW

Used only for sunspace zones (i.e., those with ZONE:SUNSPACE = YES). Electrical power per unit air flow of the venting fan. If this keyword is not specified, or is set equal to 0.0, venting is assumed to be by natural convection.

Refrigerated Casework

The following REFG keywords describe the zonal components of refrigerated casework, such as display fixtures in supermarkets. These keywords describe the operating parameters of the zonal equipment, such as the heat gains of the display fixtures. Additional keywords in the SYSTEM component are used to define the characteristics of the central refrigeration plant.

REFG-ZONE-LOAD

Required for simulation of refrigerated display fixtures. This is the total cooling effect (sensible + latent) to the zone due to air spilling from open refrigeration fixtures and by heat radiating from other surfaces to the cold surfaces of the fixtures. A list of up to three entries is allowed, all at zone design dry-bulb and relative humidity defined under keywords ZONE:REFG-ZONE-DES-T and ZONE:REFG-ZONE-DES-RH. The list entries must be made in order, starting with the coldest and progressing to the warmest evaporator temperature.

Manufacturers of supermarket fixtures usually do not list the total cooling effect of their fixtures directly. Instead, they list the compressor capacity at a standard suction temperature required per lineal foot of case work. The sensible cooling effect is typically 65% of this number, and the latent cooling effect is about 10%. The total cooling effect is then about 75% of the listed compressor capacity per lineal foot, multiplied by the lineal feet of case work.

REFG-ZONE-SHR

For the REFG-ZONE-LOADs, the ratios of sensible to total heat. Takes a list of three entries (order corresponds to REFG-ZONE-LOAD entries), all at zone design dry-bulb and relative humidity defined under keywords ZONE:REFG-ZONE-DES-T and REFG-ZONE-DES-RH.

REFG-DISCHARGE-T

Required for simulation of refrigerated display fixtures. Temperature of the air inside the cases. Takes a list of three entries (order corresponds to REFG-ZONE-LOAD entries). A simulation error will occur if the zone temperature is allowed to float below the warmest temperature in this list.

REFG-EVAP-T

Apparatus dewpoint temperature of the refrigerated display fixtures. Takes a list of three entries (order corresponds to REFG-ZONE-LOAD entries). Defaults to corresponding REFG-DISCHARGE-T minus 10F (5.6K).

REFG-SENS-SCH

Takes a list of three U-names of schedules (order corresponds to REFG-ZONE-LOAD entries) that simulate covers on case work at night and holidays to inhibit loss of sensible cooling to the zone. Alternatively, this schedule can be used with display fixtures having doors to modify the sensible loss as a function of sales (door openings). A schedule value of 1.0 means the display fixture has is uncovered or has the design number of sales. A value of 0.0 means the fixture has no sensible loss.

REFG-LAT-SCH

Used only for PSZ refrigeration simulation. Takes a list of three U-names of schedules (order corresponds to REFG-ZONE-LOAD entries) that simulate covering case work and the effect on moisture condensing inside the cases. This schedule can also modify the latent gains for fixtures having doors. A schedule value of 1.0 means the display fixture has is uncovered or has the design number of sales. A value of 0.0 means the fixture has no latent loss.

REFG-ZONE-DES-T

Specifies the design zone dry-bulb temperature at which the display fixture is rated. Takes a list of three entries (order corresponds to REFG-ZONE-LOAD entries) as referenced by REFG-ZONE-LOAD.

REFG-ZONE-DES-RH

Specifies the design zone relative humidity at which the display fixture is rated as referenced by REF-ZONE-LOAD. Takes a list of three entries (order corresponds to REFG-ZONE-LOAD entries).

REFG-AUX-KW

Takes a list of three entries (order corresponds to REFG-ZONE-LOAD entries) of fractional rated capacity of lights, fans, anti-sweat heaters and other electrical equipment inside the case. Values default to 0.4 * (corresponding REFG-ZONE-LOAD in kW).

REFG-AUX-SCH

Takes a list of three U-names (order corresponds to REFG-ZONE-LOAD entries) of schedules for turning off lights, fans, anti-sweat heaters, etc., inside the case. Applies to both REFG-AUX-KW and REFG-AUX-LOAD.

REFG-DEF-MECH

Takes a list of three code-words (order corresponds to REFG-ZONE-LOAD entries) that specify the type of defrost for the cases.

RESISTANCE	Electric resistance defrost.
FREON	Hot gas defrost.
TIME-OFF	Timer controlled off-cycle for frost melt.
NO-DEFROST	Used with units that never need defrosting, or for ice rinks.

REFG-DEF-EFF

Takes a list of three values (order corresponds to REFG-ZONE-LOAD entries) of the efficiency of the defrost mechanism. Based on the humidity ratio in the zone, the program calculates the moisture that condenses on each evaporator. It assumes that all condensation freezes and that the energy required to defrost is equal to (weight of frost)*(heat of fusion)/[REFG-DEF-EFF]. The default to 0.9, unless REFG-DEF-MECH = 'TIME-OFF', in which case the default is 1.0.

REFG-DEF-CTRL

Takes a list of three code-words (order corresponds to REFG-ZONE-LOAD entries) that specify the type of defrost control.

TIMER	Timed defrost cycle
THERMOSTATIC	Timed start with thermostat controlled off-cycle.

REFG-AUX-HEAT

Takes a list of three values (order corresponds to REFG-ZONE-LOAD entries) of non-electrical auxiliary loads, such as hot water resurfacing of an ice rink.

Ice Skating Rinks

The following set of keywords provide for the definition of an ice rink. Only one ice rink may be defined per zone, however more than one zone may have an ice rink. Only conditioned zones may have ice rinks.

The ice rink algorithm calculates the major rink loads on an hourly basis. These loads are comprised of:

Convective loads – these consist of sensible and latent heat gains that arise from the contact of conditioned zone air with the ice surface. In addition to varying with zone temperature and humidity, these loads may also vary in accordance with the rate of forced convection arising from the operation of the HVAC system, as well as from the movement of skaters over the ice.

Radiative loads – these consists of radiation emitted from the lights, the ceiling surface, and skylights. Lighting loads are calculated as a function of the scheduled lighting energy (various keywords in the SPACE command), the fraction of lighting energy that enters this space (SPACE:LIGHT-TO-SPACE), and the fraction of lighting energy that is radiative (ZONE:LIGHTS-RAD). Ceiling radiation is calculated as a function of the ceiling temperature, view factor, and emissivity. The ceiling temperature is in turn calculated as a function of the thermal balance between the outside air temperature, the zone temperature, and the ice rink temperature. Skylight loads are calculated assuming that all windows in the space are in the ceiling, have the same view factor of the ice rink as does the ceiling, and that the amount of solar radiation absorbed by the ice is directly proportional to the view factor. The program assumes that other building surfaces, such as interior or exterior walls, do not contribute significantly to the ice rink load.

Ice resurfacing loads – these arise from the warm water used to periodically refinish the ice surface, as well as the resurfacing machine. Ice resurfacing loads may affect both the zone as well as the ice.

Skater loads - the program assumes that all of the people defined/scheduled in the SPACE command affect the ice. A portion of the occupant sensible heat gain is assumed captured by the ice.

Subfloor heating – most rinks utilize insulation and a subfloor heating system to prevent the damage that may result from moisture freezing and expanding below the ice surface (frost heave). The program assumes a constant cooling load arises from this subfloor heating. Subfloor heating may be provided by either hot water or electric resistance coils.

Ice rink loads that arise from hourly zone interactions also affect the zone load (temperature) and system humidity; note however that ice rink loads are not taken into account in the initial design calculations for HVAC equipment.

Report RS-I automatically prints for each occurrence of an ice rink. This report summarizes the total, peak, and time of peak heat gains due to the various loads on a monthly and yearly basis.

ICE-RINK

accepts a code-word specifying whether this zone has an ice rink. This keyword acts as a toggle to activate the following keywords.

NO	specifies that no ice rink exists.
YES	specifies that an ice rink exists. Each conditioned zone may have one ice rink.

RINK-AREA

specifies the surface area of the ice rink. This is a required keyword.

RINK-SETPT-T

specifies the average temperature of the ice in the rink. The default is 22F. This value is used in all design calculations. On an hourly basis, this value may be overridden by the RINK-SETPT-SCH.

If the brine loop temperature is reset on load, this value is used, together with the rink cooling load and the RINK-BRINE-DT, in determining the required brine temperature.

RINK-SETPT-SCH

accepts the U-name of a schedule defining the desired temperature of the ice in the rink. The default is the RINK-SETPT-T.

RINK-SETPT-RNG

specifies the throttling range of the rink temperature controller. Typical controllers have a range of 5°F. Infrared controllers can reduce the range to approximately 2°F.

STRATIFICATION

specifies a fractional term describing the degree to which the air in immediate contact with the ice rink is stratified from the zone air. Since most ice rinks are partially isolated from their zone by a low barrier, and because HVAC systems are typically designed to not directly blow on the ice, the air temperature and humidity above the ice will typically be less than the zone conditions.

A value of 0.0 means that the air is not stratified; the air in contact with the ice surface is at the zone temperature and humidity. This results in maximum convective heat gain to the ice. A value of 1.0 means that the air is fully stratified; the air in contact with the ice surface is at the ice temperature and humidity. This results in no convective heat gain to the ice. The default is 0.5

LIGHTS-RAD

specifies the fraction of light energy entering this space that is radiative. The radiative fraction is absorbed by the ice in direct proportion to the ceiling view factor.

SKATER-WORK

specifies the fraction of the sensible heat gain of people in the space that results in a cooling load on the ice. This term should include the work directly done on the ice by the skaters, as well their the convective and radiative contributions.

SKATER-WIND

specifies the windspeed contributed by people moving over the ice at design conditions. This windspeed varies hourly in proportion to the square root of the people schedule value, and acts to modify the sensible and latent convective heat transfer coefficients. The default is 5 feet/minute.

HVAC-WIND

specifies the windspeed contributed by the HVAC system when the system is scheduled on. It acts to modify the sensible and latent convective heat transfer coefficients. The default is 5 feet/minute.

RESURF-Q-ZONE

specifies the load to the zone created by the ice resurfacing machine. The default is 0 Btu/hr.

RESURF-H2O

specifies the amount of water in gallons used to resurface the ice. The default is 0.006 gallons/sq-ft of rink area.

RESURF-SCH

accepts the U-names of a schedule defining the resurfacing schedule. This schedule modifies both the RESURF-Q-ZONE and RESURF-H2O quantities on an hourly basis. For example, if resurfacing is done every other hour during occupied hours, then this schedule should contain a value of 1.0 for each hour that resurfacing occurs, and 0.0 for all other hours. If no schedule is defined, then resurfacing is assumed to occur every hour.

RESURF-H2O-T

specifies the temperature of the water placed on the ice in the resurfacing process. The default is 150F.

RINK-EMISS

specifies the emissivity of the ice rink. This value is used in calculating the radiant exchange between the ceiling and the ice surface. The default is 0.95

CEILING-EMISS

specifies the emissivity of the ceiling. This value is used in calculating the ceiling surface temperature, and the radiant exchange between the ceiling and the ice. The default is 0.90.

CEILING-VIEW

specifies the ceiling view factor to the ice. This value is used in calculating the ceiling surface temperature, and the radiant exchange between the ceiling and the ice. In addition, lighting and solar radiation are assumed to be absorbed by the ice in direct proportion to the view factor. The default is 0.7.

CEILING-FILM-RES

specifies the convective film coefficient of the inside ceiling film layer, excluding the effect of radiation. The program uses this value, together with the ceiling emissivity, ceiling R-value, ice emissivity, and surface temperatures, to calculate the hourly heat balance.

The default is 5.8 hr-ft²-F/Btu. This value is derived from the ASHRAE value for a horizontal surface with downward heat flow, when radiation is excluded. It is recommended that you not change this value.

RINK-RESPONSE

accepts a list of 4 fractional values that act to delay the effect of the gross hourly rink load on the brine loop. Because the ice is several inches thick, a load imposed on the surface will not immediately become a load on the brine loop. The default is (0.25, 0.375, 0.25, 0.125). These values must add up to 1.0.

The hourly brine load is:

$$Q_{\text{brine}} = Q_{\text{rink}} * W_1 + Q_{\text{rinkt-1}} * W_2 + Q_{\text{rinkt-2}} * W_3 + Q_{\text{rinkt-3}} * W_4$$

where Q_{rink} , $Q_{\text{rinkt-1}}$, etc. are this hours and previous hours instantaneous ice load, and the W terms are the rink response factors.

BRINE-LOOP

accepts the U-name of a CIRCULATION-LOOP of TYPE = CHW. This is a required keyword.

Since this loop provides cooling to the ice rink, you must define its operational values accordingly. For example, this loop must be assigned a design setpoint temperature colder than the RINK-SETPT-T. Any chillers attached to this loop must have electric-input-ratios and performance curves consistent with operation using brine at the required temperature. Also, ice rinks normally have design brine temperature drops significantly less than the 10°F typical for chilled-water loops (3°F is common).

BRINE-FLOW

specifies the design brine flow through the ice rink. The default is calculated based on the design rink cooling load, and assuming 40% ethylene glycol at 0°F.

BRINE-HEAD

specifies the pressure drop of the brine as it flows through the rink. The default is 20 feet.

BRINE-VALVE-TYPE

accepts a code word specifying the type of flow control for the brine flowing through the rink:

THREE-WAY	produces a constant flow independent of actual hourly load.
TWO-WAY	specifies a flow that varies with load. For ice rinks, the flow is assumed to vary linearly with load.

BRINE-DT

specifies the design temperature rise of the brine flowing through the rink. The default is the BRINE-LOOP:LOOP-DESIGN-DT.

RINK-BRINE-DT

specifies the design differential between the RINK-SETPT-T and the brine temperature. This value is used only when the temperature of the brine loop is reset based on load. In that case, the program calculates the required brine temperature as

$$T_{\text{brine}} = \text{RINK-SETPT-T} - \text{RINK-BRINE-DT} * Q_{\text{rink}} / Q_{\text{rink-design}}$$

SUBFLOOR-HEATER

accepts a code-word specifying the type of subfloor heater. The heater adds enough heat to keep the ground below the rink safely above freezing. The default is no heater.

HOT-WATER specifies that warm water circulates through tubing below the subfloor.

ELECTRIC specifies that electric resistance heating elements provide the heat.

SUBFLOOR-SETPT-T

specifies the subfloor temperature setpoint. The default is 50°F.

SUBFLOOR-RESIS

specifies the effective resistance between the ice at the RINK-SETPT-T and the subfloor heater at the SUBFLOOR-SETPT-T. This resistance includes any insulating materials used, as well as the resistance of any concrete, sand, earth, etc. separating the subfloor heating coils from the ice.

SUBFLOOR-LOOP

when SUBFLOOR-HEATER = HOT-WATER, accepts the U-name of a CIRCULATION-LOOP of TYPE = HW that will provide the subfloor heating. Since the subfloor need only be a safe temperature above freezing, this loop may operate at a relatively low temperature (60°F or so), and is a good candidate for heat recovery from the chiller(s) serving the loop that cools the rink.

SUBFLOOR-FLOW

when SUBFLOOR-HEATER = HOT-WATER, specifies the design flow through the subfloor piping. The default is based on the design subfloor load, temperature drop, and assuming a 40% ethylene glycol solution.

SUBFLOOR-HEAD

when SUBFLOOR-HEATER = HOT-WATER, specifies the design head loss through the subfloor. The default is 20 feet.

SUBFLOOR-VALVE

when SUBFLOOR-HEATER = HOT-WATER, specifies the type of valve control for the subfloor flow. Since subfloor heating loads are currently modeled as constant all hours, this keyword has no meaning.

SUBFLOOR-DT

when SUBFLOOR-HEATER = HOT-WATER, specifies the design temperature drop through the subfloor piping. The default is the SUBFLOOR-LOOP:LOOP-DESIGN-DT.

SUBFLOOR-METER

when SUBFLOOR-HEATER = ELECTRIC, specifies the electric meter that provides the heating energy. The default is the REFG-ELEC-METER of the zone.

Zone Meters

The following -METER keywords specify electric and fuel metering at the ZONE level. The program has a hierarchy of meter defaulting that starts at the MASTER-METER level, and works its way down through SYSTEMs to the ZONEs:

The electric end-use meters at the MASTER-METER level default to the MASTER-METER's MSTR-ELEC-METER. Fuel meters default in the same way.

The electric end-use meters at the SYSTEM level default to the SYSTEM's MSTR-ELEC-METER, or if not specified, to the MASTER-METER's end-use meter of the same type. For example, a SYSTEM's LIGHT-ELEC-METER will default to the SYSTEM's MSTR-ELEC-METER, or to the MASTER-METER's LIGHT-ELEC-METER. The MASTER-METER's LIGHT-ELEC-METER in turn defaults to the MASTER-METER's MSTR-ELEC-METER. Fuel meters default in a similar fashion.

The electric end-use meters at the ZONE level default to the ZONE's MSTR-ELEC-METER, or if not specified, to its parent SYSTEM's end-use meter of the same type. The parent SYSTEM's end-use meter in turn defaults to the SYSTEM's MSTR-ELEC-METER, or if not specified, to the MASTER-METER's end-use meter of the same type. The MASTER-METER's end-use meters in turn default to the MASTER-METER's MSTR-ELEC-METER. Fuel meters default in a similar fashion.

Since central plant equipment (boilers, chillers, etc.) can span across multiple ZONEs and multiple SYSTEMs, their meters default directly to the appropriate end-use meters at the MASTER-METER level.

If you do nothing but specify the MASTER-METER's MSTR-ELEC-METER and MSTR-FUEL-METER, all meters in all components will default to those meters.

MSTR-ELEC-METER

Accepts the U-name of the electric meter to be used as the master electric meter. All electric meter attachments in all components will default to this meter unless specified otherwise within the component command, or unless the appropriate master end-use meter is specified (see following).

MSTR-FUEL-METER

Accepts the U-name of the fuel meter to be used as the master fuel meter. All fuel meter attachments in all components will default to this meter, unless specified otherwise within the component command, or unless the appropriate master end-use meter is specified (see following).

LIGHT-ELEC- METER

Accepts the U-name of the electric meter to be used as the master electric meter for all general lighting. The default is the MSTR-ELEC-METER.

TASK-ELEC-METER

Accepts the U-name of the electric meter to be used as the master electric meter for all task lighting. The default is the MSTR-ELEC-METER.

EQUIP-ELEC-METER

Accepts the U-name of the electric meter to be used as the master electric meter for all miscellaneous equipment (computers, copiers, etc.). The default is the MSTR-ELEC-METER.

SOURCE-ELEC-METER

Accepts the U-name of the electric meter to be used as the master electric meter for all source usage. The default is the MSTR-ELEC-METER.

HEAT-ELEC-METER

Accepts the U-name of the electric meter to be used as the master electric meter for all space heating. The default is the MSTR-ELEC-METER.

COOL-ELEC-METER

Accepts the U-name of the electric meter to be used as the master electric meter for all space cooling. The default is the MSTR-ELEC-METER.

HTREJ-ELEC-METER

Accepts the U-name of the electric meter to be used as the master electric meter for all heat-rejection equipment (cooling towers, etc.). The default is the MSTR-ELEC-METER.

AUX-ELEC-METER

Accepts the U-name of the electric meter to be used as the master electric meter for all HVAC auxiliary equipment (pumps, etc.). The default is the MSTR-ELEC-METER.

VENT-ELEC-METER

Accepts the U-name of the electric meter to be used as the master electric meter for all ventilation fans. The default is the MSTR-ELEC-METER.

REFG-ELEC-METER

Accepts the U-name of the electric meter to be used as the master electric meter for all refrigeration equipment. The default is the MSTR-ELEC-METER.

SUPP-ELEC-METER

Accepts the U-name of the electric meter to be used as the master electric meter for all supplemental heating in electric heat-pumps. The default is the MSTR-ELEC-METER.

DHW-ELEC-METER

Accepts the U-name of the electric meter to be used as the master electric meter for all water heating equipment. The default is the MSTR-ELEC-METER.

SOURCE-FUEL-METER

Accepts the U-name of the electric meter to be used as the master fuel meter for all source usage. The default is the MSTR-FUEL-METER.

HEAT-FUEL-METER

Accepts the U-name of the electric meter to be used as the master fuel meter for all space heating. The default is the MSTR-FUEL-METER.

COOL-FUEL-METER

Accepts the U-name of the electric meter to be used as the master fuel meter for all space cooling. The default is the MSTR-FUEL-METER.

SUPP-FUEL-METER

Accepts the U-name of the fuel meter to be used as the master fuel meter for all supplemental heating in electric heat-pumps. The default is the MSTR-FUEL-METER.

DHW-FUEL-METER

Accepts the U-name of the fuel meter to be used as the master fuel meter for all water heating equipment. The default is the MSTR-FUEL-METER.

Miscellaneous**ZONE-REPORTS**

Determines if non-hourly reports (SUMMARY and VERIFICATION) are to be produced for this ZONE. YES indicates that all requested reports are to be produced.

FUNCTION

Invokes a function calculation for the zone. Takes a list of two U-names, enclosed in asterisks, of previously-defined FUNCTION commands. If the U-names are U-name1 and U-name2, possible assignments are as follows:

```
FUNCTION = (*U-name1*, *NONE*)
```

```
FUNCTION = (*NONE*, *U-name2*)
```

```
FUNCTION = (*U-name1*, *U-name2*)
```

In the first case, the calculation of the function with NAME = *U-name1* will be done before the execution of the subroutine associated with the function. In the second case, the calculation of the function with NAME = *U-name2* will be done after the execution of the subroutine associated with the function. In the third case, the function with *U-name1* will be calculated before, and the function with *U-name2* will be calculated after the subroutine's execution.

Economic Components

This section describes the commands and keywords used in the economic calculations. Included here are the descriptions for the:

Equipment costs – These include first costs, maintenance costs, and replacement costs.

Utility Rates – This set of components allows you to describe most of the commonly used utility rates for electricity, fuels, steam and chilled-water meters. Included are block structures and ratchets.

BASELINE

Specifies the baseline condition against which an alternative energy conservation project can be elevated. Baseline figures may be used from a previous program run or they may be based on actual operating data for the building under construction. In either case, ECONOMICS compares the calculated life-cycle costs of the present run with the baseline figures and arrives at a dollar and energy savings relative to the baseline case. From this comparison, the program calculates the statistics that provide a measure of the investment cost effectiveness of the energy conservation alternative under consideration.

Example input:

\$ Baseline Costs

BASELINE

```
PROJECT-LIFE      = 25
DISCOUNT-RATE   = 5
ENERGY-COST       = ( 4465,4526,4587,4650,4714,4779,
                    4845,4912,4981,5051,5123,5195,
                    5269,5345,5422,5501,5581,5662,
                    5745,5830,5916,6004,6093,6185,
                    6278.)
ENERGY-USE-SITE   = 387.86
ENERGY-USE-SRC    = 729.76 ..
```

ELEC-TARIFF = UTILITY-RATE

```
TYPE              = ELECTRICITY
ENERGY-CHG-SCH    = ENERGY-SCH
ESCALATION        = 7 ..
```

ENERGY-SCH = SCHEDULE

```
TYPE              = FRACTION
THRU DEC 31       (WD) ( 1, 8)(.05)      $OFF-PEAK
                  ( 9,12)(.06)      $SHOULDER
                  (13,17)(.07)      $PEAK
                  (18,22)(.06)      $SHOULDER
                  (23,24)(.05)      $OFF-PEAK
(SAT) ( 1, 8)(.05)      $OFF-PEAK
                ( 9,17)(.06)      $SHOULDER
                (18,24)(.05)      $OFF-PEAK
(SUN,HOL) (1,24)(.05)      $OFF-PEAK
```

..

GAS-RATE =UTILITY-RATE

```
TYPE              = NATURAL-GAS
ENERGY-CHG        = 0.6 ..
```

FIRST-COST

Specifies in dollars the total baseline initial costs, including installation. If the baseline is an existing, unmodified building, the value of FIRST-COST should be zero.

REPLACE-COST

Specifies in dollars the present value of the life-cycle baseline replacement cost for plant and non-plant components.

Table 48 shows what output report to refer for values of the above keywords if baseline data are to be taken from a previous program run.

Table 48 Output Reports for Baseline Values

Keyword	ECONOMICS Output Report	Designation in Report
FIRST-COST	ES-B	FIRST-COST (including installation), TOTAL
REPLACE-COST	ES-B	REPLACEMENTS, TOTAL
OPERATIONS-COST	ES-A	OPRNS COST - THIS RUN, TOTAL, YEAR 1, 2, 3, etc
ENERGY-COST	ES-A	ENERGY COST THIS RUN, YEAR 1, 2, 3, etc.
ENERGY-USE-SITE	ES-C	ANNUAL ENERGY USE - THIS RUN, AT SITE
ENERGY-USE-SRC	ES-C	ANNUAL ENERGY USE - THIS RUN, AT SITE

OPERATIONS-COST

The value of this keyword is a list, up to 25 entries long, that gives the present value of operations and energy costs for each year of the baseline project lifetime. If the project life is N years (as specified in PDL) then N values of operations costs must be given sequentially for years 1, 2, ..., N.

ENERGY-COST

The value of this keyword is a list, up to 25 entries long, that gives the present value of operations and energy costs for each year of the baseline project lifetime. If the project life is N years (as specified in PDL) then N values of operations costs must be given sequentially for years 1, 2, ..., N.

ENERGY-USE-SITE

Specifies the baseline annual energy use, in 106 Btu at the site, i.e., at the building boundary.

ENERGY-USE-SRC

Specifies the baseline annual energy use, in 106 Btu at the source. For example, if electricity production by a utility has an overall efficiency, including transmission losses, of 1/3, then 1 kWh (3413 Btu) of electricity use at the site would correspond to $3 \times 3413 = 10,239$ Btu of energy use at the source.

DISCOUNT-RATE

Specifies the discount rate (in percent), which is the factor used in a present-value method of economic evaluation that accounts for the time value of money. It represents the "cost of capital" or "the opportunity to earn from normal investment activity," and is used to discount future recurring costs and/or benefits to present value in decision making. One way of understanding the concept of present value and discount rate is to think of a reduced sum of money being put aside today to cover future costs. The discount rate is the interest rate applied to that sum, compounded each year, to yield in the future an amount exactly equal to the future cost. The same concept is applied to future benefits, to find their present value.

LABOR-INFLTN

Specifies the anticipated yearly percentage increase in the cost of labor, over and above the increase caused by general inflation (i.e., this is a differential or relative cost escalation).

MATERIALS-INFLTN

Specifies the anticipated yearly percentage increase in the cost of materials, over and above the increase caused by general inflation (i.e., this is a differential or relative cost escalation). The program applies the materials inflation rate to the calculation of cost for consumables and to the cost of procuring replacements. MATERIALS-INFLTN is also applied to overhaul costs and replacement installation costs.

PROJECT-LIFE

The period over which life-cycle costs are calculated. This entry should not include the initial construction or installation period.

LABOR

Specifies the dollar cost per hour of maintenance labor.

SITE-FACTOR

Specifies a number that can be used to adjust annual equipment-related costs (specifically, the cost of maintenance and consumables) when these are affected by location.

BLOCK-CHARGE

BLOCK-CHARGE_s are used to calculate energy or demand costs that vary according to the amount consumed. BLOCK-CHARGE_s are also used for time-of-use demand charges. Up to 30 BLOCK-CHARGE_s may be defined, and up to 10 may be referenced by each UTILITY-RATE. The same BLOCK-CHARGE may be referenced by more than one UTILITY-RATE; the program automatically makes as many working copies as are required. See the RATCHET command.

BLOCK-CHARGE defines the energy or demand charges that vary according to the amount used. The time period over which a BLOCK-CHARGE is used is defined in a schedule so that different rates can be used at different times of the year. When a time-of-use demand charge is being assessed, this schedule allows demands to be billed for different times of the day and season. BLOCK-CHARGE_s allow costs that vary with quantity to be computed, such as \$0.05 for the first 5000 kWh, \$0.035 for the next 10000 kWh, etc. BLOCK-CHARGE_s for energy and demand take the metered values for the billing period as determined in the parent UTILITY-RATE. These are adjusted by any minimum quantities and ratchets to determine the billing quantities. Block costs are calculated on the basis of the billing quantities. If a seasonal change in a schedule causes BLOCK-CHARGE_s to be switched in the middle of the billing period, the calculated costs are prorated between the two BLOCK-CHARGE_s on the basis of the number of hours each was active.

BLOCK-CHARGE_s for time-of-use demands, such as on-peak and off-peak, are slightly different. Instead of taking the peak demand for the billing period as determined in the parent UTILITY-RATE, the BLOCK-CHARGE directly determines the demand for the time periods defined in its schedule. This demand is then adjusted by any associated RATCHET_s (which may also be defined strictly for the same time period). This billing charge is then used in the cost calculations.

Each time-of-use demand period must be defined in a separate BLOCK-CHARGE. If on-peak, shoulder, and off-peak demands are calculated for two seasons, a total of six BLOCK-CHARGE_s are required. If seasons change in the middle of a billing period, then the BLOCK-CHARGE_s associated with each season must be linked to each other so that the correct demand for the billing period is computed. Costs are then based on the maximum demand found in the billing period, and are prorated on the basis of the number of hours each was active.

If a UTILITY-RATE has a block structure for both energy and demand charges, the same BLOCK-CHARGE may be used to model both. When modeling both, the energy and demand BLOCK-TYPE keywords may be specified in any order. Alternatively, separate BLOCK-CHARGE_s can be used for energy and demand. This may be useful when the BLOCK-SCH for the energy and demand charges do not coincide. As previously described, each UTILITY-RATE can reference up to 10 BLOCK-CHARGE_s.

While KWH/KW, KWH/KW-LIMITSUM and DEMAND are normally used for electrical rates, they may be used for any fuel or utility. In this case, the meaning of KWH/KW would be (UNIT consumption)/(peak UNIT consumption). The same is also true of demand ratchets; they may in principal be applied to any fuel or utility. Note also that the demand period may be changed from 5 minutes to 1 day via the DEMAND-WINDOW in the parent UTILITY-RATE.

U-name is a unique user-defined name that must be entered to identify this command.

Example input:

```
"Win OffPeak" = BLOCK-CHARGE
  BLOCK-SCH           = "TOU8 Time Sched"
  SCH-FLAG            = 1.1
  BLOCK1-TYPE         = ENERGY
  BLOCKS-1            = (1)
  COSTS-1             = (0.04335)
```

```

BLOCK2-TYPE      = DEMAND
BLOCKS-2         = (1)
COSTS-2          = (0.0001)
..

"Win MidPeak" = BLOCK-CHARGE
BLOCK-SCH        = "TOU8 Time Sched"
SCH-FLAG         = 1.2
BLOCK1-TYPE      = ENERGY
BLOCKS-1         = (1)
COSTS-1          = (0.07688)
BLOCK2-TYPE      = DEMAND
BLOCKS-2         = (1)
COSTS-2          = (0.0001)
..

"Sum OffPeak" = BLOCK-CHARGE
BLOCK-SCH        = "TOU8 Time Sched"
SCH-FLAG         = 2.1
BLOCK1-TYPE      = ENERGY
BLOCKS-1         = (1)
COSTS-1          = (0.04077)
BLOCK2-TYPE      = DEMAND
BLOCKS-2         = (1)
COSTS-2          = (0.0001)
..

"Sum MidPeak" = BLOCK-CHARGE
BLOCK-SCH        = "TOU8 Time Sched"
SCH-FLAG         = 2.2
BLOCK1-TYPE      = ENERGY
BLOCKS-1         = (1)
COSTS-1          = (0.06517)
BLOCK2-TYPE      = DEMAND
BLOCKS-2         = (1)
COSTS-2          = (2.35)
..

"Sum Peak" = BLOCK-CHARGE
BLOCK-SCH        = "TOU8 Time Sched"
SCH-FLAG         = 2.3
BLOCK1-TYPE      = ENERGY
BLOCKS-1         = (1)
COSTS-1          = (0.13752)
BLOCK2-TYPE      = DEMAND
BLOCKS-2         = (1)
COSTS-2          = (15.75)
..

"24-Hour Demand" = BLOCK-CHARGE
BLOCK-SCH        = "24-Hour On Sched"
SCH-FLAG         = 1
DEMAND-RATCHETS = ("50% Ratchet")
BLOCK1-TYPE      = DEMAND
BLOCKS-1         = (1)

```

COSTS-1 = (3.15)

..

BLOCK-SCH

Takes the U-name of a SCHEDULE that defines the period over which energy or demand from the METERS specified in the parent UTILITY-RATE is accumulated. For all energy charges, the schedule is primarily used only for seasonal changes in block charges, such as winter vs. summer rates; time-of-use rates are normally defined directly in the UTILITY-RATE via the ENERGY-CHG-SCH keyword. However, if energy charges vary both by time-of-use as well as amount, then BLOCK-CHARGE_s are applicable.

It is not necessary for seasons to begin and end on the BILLING-DAYS; the program will prorate charges when a seasonal change occurs in the middle of the billing period. You should be careful, however, to ensure that one or more other BLOCK-CHARGE_s are defined for the periods in which this BLOCK-CHARGE is inactive. You may define as many seasons as required. For conventional block demand charges, seasonal changes are handled identically to energy block charges. For energy or demand charges levied on a time-of-use basis, such as peak, shoulder, and off-peak, this schedule may vary on an hourly and daily basis, as well as seasonal basis.

SCH-FLAG

Specifies the flag value in the BLOCK-SCH that indicates when this BLOCK-CHARGE is active.

DEMAND-RATCHETS

Specifies a list enclosed in parentheses of up to five u-named RATCHETS. The default are the ratchets listed in the parent UTILITY-RATE in DEMAND-RATCHETS. The billing demand used in the BLOCK CHARGE is the largest of

The actual monthly demand; or

A RATCHET(s) demand, if defined; or

The minimum DEMAND-QUAL.

For DEMAND-QUAL to be used, it must be specified and USE-MIN-QUALS must be YES. This billing demand is used both for demand calculations well as for KWH/KW and KWH/KW-LIMITSUM calculations. Ratchets listed here have no other effect on either the parent UTILITY-RATE or other BLOCK-CHARGE_s.

TOU-SEASON-LINKS

This keyword is used only with a time-of-use rate where different BLOCK-CHARGE_s are used at different times of the day, and is required only when seasonal changes in rates occur on a day which does not coincide with the billing-day. In this case, the two BLOCK-CHARGE_s overlap in the same billing period and must be linked so that the correct energy and/or demand charges can be determined for both blocks. (Charges for each block must be based on the same use period, such as on-peak, and then prorated based on the number of hours each block was active during the billing period. Input is a list of u-name(s) in parenthesis of the linked BLOCK-CHARGE(s) which share the same billing period. Both BLOCK-CHARGE_s must reference each other via this keyword. If only two seasons are used, this BLOCK-CHARGE will overlap with only one other BLOCK-CHARGE, so that only one u-name is entered. If more than two seasons are used, such as winter, spring, summer and fall, this BLOCK-CHARGE will overlap with two other BLOCK-CHARGE_s. For example, a BLOCK-CHARGE representing spring will overlap with both winter and summer BLOCK-CHARGE_s. In this case, the u-names of the winter and summer BLOCK-CHARGE_s are input.

BLOCKS-ARE

For energy-type blocks, accepts a code-word specifying the meaning of the entries in BLOCKS-1 through BLOCKS-5. Allowed values are:

INCREMENTAL	Indicates that each successive block entry covers the next size block.
CUMULATIVE	Indicates that each successive block also includes the energy of all previous blocks.

For example, an electric utility lists its charges as follows:

Up to 1000 kWh	\$0.05/kWh
Up to 3500 kWh	\$0.07/kWh
Above 3500 kWh	\$0.08/kWh

This rate can be entered in either of the following formats, both of which will produce the same answer:

BLOCKS-ARE	= INCREMENTAL
BLOCKS-1	= (1000, 2500, 1)
COSTS-1	= (0.05, 0.07, 0.08)

BLOCKS-ARE	= CUMULATIVE
BLOCKS-1	= (1000, 3500, 1)
COSTS-1	= (0.05, 0.07, 0.08)

BLOCK1-TYPE
BLOCK2-TYPE
BLOCK3-TYPE
BLOCK4-TYPE
BLOCK5-TYPE

When energy calculations are being made, this keyword allows the type of energy calculation to change. For example, a utility may start with a series of ENERGY blocks and then change to kWh/kW blocks. Alternatively, energy blocks may switch to demand. Code-word defines the type of block calculation follows. Allowed code-words are:

ENERGY	The default; used when the cost calculations will be done on a per unit basis of energy consumption.
KWH/KW	Specifies calculations for energy consumption where each block size is defined as a multiplier on demand. When the number of kWh that can be in a given kWh/kW block is limited to a maximum value, a limit can be specified (see keyword BLOCK-DATA).
KWH/KW-LIMITSUM	Used when the sum of the kWh in a series of ENERGY blocks is limited by a kWh/kW value. The maximum value is specified in the BLOCK-DATA.
DEMAND	Specifies that this set of BLOCK-CHARGE _s will be used to calculate demand charges.

BLOCKS-1**BLOCKS-2****BLOCKS-3****BLOCKS-4****BLOCKS-5**

Accept a list in parentheses of the size of the blocks to which COSTS-1 through COSTS-5, respectively, will be applied. Blocks may be either incremental or cumulative, depending on the value of BLOCKS-ARE, which defaults to INCREMENTAL. When INCREMENTAL, each entry in the list covers the next size block.

When EBLOCKS-ARE = CUMULATIVE, each succeeding entry must be larger than the previous entry, as this implies rates structured in the "up to X" format of energy blocks.

COSTS-1**COSTS-2****COSTS-3****COSTS-4****COSTS-5**

Accept a list in parenthesis of the cost/unit to be applied against the energy or demand falling in the corresponding entry in BLOCKS-1 through BLOCKS-5, respectively.

LIMITS-1**LIMITS-2****LIMITS-3****LIMITS-4****LIMITS-5**

for KWH/KW and KWH/KW-LIMITSUM types, accept a list in parenthesis specifying the limits for BLOCKS-1 through BLOCKS-5, respectively. An entry of 0.0 means there is no limit. When BLOCK-UNIT is KWH/KW, the limit has units of kWh and is the maximum quantity of energy that can be charged in this block. When BLOCK-UNIT is KWH/KW-LIMITSUM, this entry has units of kWh/kW and, when multiplied by demand, is the maximum sum of all energy that can be charged in this block and all previous blocks. Usually, one limit will apply to a series of blocks. In this case the same limit should be entered for each of the affected blocks.

COMPONENT-COST

Specifies cost data for non-plant components (first cost, installation cost, annual cost, and cost of major and minor overhauls). Non-plant components are here defined as everything except the primary energy conversion equipment, such as boilers, chillers, diesel generators, gas turbines, storage tanks, etc. A non-plant component can be anything from roof insulation, to an HVAC system, to a solar collector system, to an entire building. Cost for up to 15 different non-plant components may be specified, using a separate COMPONENT-COST instruction for each. The ECONOMICS program calculates the present value of the life-cycle costs for the components. Costs are per unit; program calculates the net cost by multiplying per-unit cost by NUMBER-OF-UNITS]. All costs should be in current dollars.

Example input:

```
ROOF-INSUL =COMPONENT-COST
UNIT-NAME      = *SQFT*
NUMBER-OF-UNITS = 5000
FIRST-COST     = 0.80
INSTALL-COST   = 0.30 . .
```

ANNUAL-COST

Specifies the unit maintenance (labor) and consumables (materials) cost per year for the component.

COMPONENT-LIFE

Specifies the component's useful life in years. This value is used to calculate life-cycle replacement costs. For example if COMPONENT-LIFE=n is specified. Replacement and installation cost are calculated at intervals of n years, up to the lifetime of the project. The default value for COMPONENT-LIFE is 999 years, so that if this keyword is not specified, replacement costs will be ignored.

FIRST-COST

Specifies initial cost per unit, in dollars, excluding installation.

INSTALL-COST

Specifies unit maintenance (labor) and consumables (materials) cost per year for the component. The differential labor inflation rate is applied to annual cost if entry is made for keyword LABOR-INFLTIN in the PLANT-COST command in PLANT.

MAJ-OVHL-COST

Specifies in dollars the cost of a major overhaul of one unit of the component.

MAJ-OVHL-INT

Specifies in years the anticipated time between major overhauls for the component.

MIN-OVHL-COST

Specifies in dollars the cost of a minor overhaul of one unit of the component.

MIN-OVHL-INT

Specifies in years the anticipated time between minor overhauls of the component.

NUMBER-OF-UNITS

Specifies the number of units of type or size described above (see keyword UNIT-NAME) that are to be costed. The program multiplies the unit costs by this value to obtain the total cost of the component. This data entry may be omitted if the component specified is a single unit.

UNIT-NAME

Any word of sixteen or fewer characters, enclosed in asterisks, that describes the size or type of unit to which the unit costs subsequently specified are referenced, for example, SQFT, TONS, LBS, FEET. This is an optional keyword; for user convenience in identification of input data.

ECONOMICS-REPORT

Selects VERIFICATION and/or SUMMARY reports for the ECONOMICS program.

Example:

```
ECONOMICS-REPORT
  VERIFICATION      = (LV-A)
  SUMMARY           = (SS-A, SS-E)
  ..
```

VERIFICATION

Takes a list of code-words of verification reports. VERIFICATION = (ALL-VERIFICATION) causes all verification reports to be printed. Examples are shown in *DOE-2.2 Libraries & Reports*.

EV-A LIFE-CYCLE COSTING PARAMETERS
Summarizes the various parameters in the life-cycle cost calculations

SUMMARY

Takes a list of code-words of summary reports. SUMMARY = (ALL-SUMMARY) causes all summary reports to be printed. Examples are shown in *DOE-2.2 Libraries & Reports*.

ES-A ANNUAL ENERGY AND OPERATIONS COSTS AND SAVINGS
This report gives the present value of energy and operations costs for each year of the project lifetime. Costs are given both for the baseline and for the building being analyzed in the present run. Operations include costs of annual maintenance and major and minor overhauls. For the building being analyzed in this run, operations costs are given separately for plant equipment and for the building (non-plant) components specified using COMPONENT-COST instructions.

ES-B LIFE-CYCLE BUILDING AND PLANT NON-ENERGY COSTS
This report summarizes life cycle costs (other than for energy) for plant equipment and for each building component.

ES-C ENERGY SAVINGS, INVESTMENT STATISTICS, AND OVERALL LIFE-CYCLE COSTS
This report summarizes the annual energy use at the site and at the source for the baseline building and for the present building. Also summarizes the life cycle costs and savings for the following categories: first cost (including installation), operations, replacements, energy, and the sum of all these.

ES-D ENERGY COST SUMMARY
This report summarizes the yearly energy consumption and cost for all UTILITY-RATEs defined.

ES-E SUMMARY OF UTILITY-RATE <utility rate name>
This report summarizes the key costs for each UTILITY-RATE. The top of the report contains general information about the UTILITY-RATE as input by you or defaulted. The remainder of the report summarizes cost by month.

ES-F BLOCK-CHARGES AND RATCHETS FOR <utility rate name>
For each UTILITY-RATE this report summarizes the cost associated with each BLOCK-CHARGE, and the monthly RATCHET values. The summary varies somewhat for energy and demand BLOCK-CHARGEs.

ES-G SUMMARY OF POLLUTANT PRODUCTION
This report gives monthly values of atmospheric pollutant production associated with the combustion of various types of fuel, both on-site and off-site at the utility power plant that supplies electricity to the building. Six types of pollutants are listed: carbon dioxide, sulfur dioxide, nitrogen oxides, carbon monoxide, hydrocarbons and particulate matter. (The following report, ES-H, gives pollutant production by time-of-use period.) See "Pollutant Production Calculation" in the *DOE-2.2 Topics*.

ES-H POLLUTANT PRODUCTION BY BLOCK-CHARGE

This report shows monthly atmospheric pollutant production according to time-of-use in the month. As in Report ES-G, "Summary of Pollutant Production," six pollutants are listed: carbon dioxide, sulfur dioxide, nitrogen oxides, carbon monoxide, hydrocarbons and particulate matter. These pollutants are produced on-site and at the utility power plant that supplies electricity to the building.

REPORT-FREQUENCY

Not used, since the ECONOMICS program does not utilize hourly-reports

HOURLY-DATA-SAVE

Not used, since the ECONOMICS program does not utilize hourly reports

POLLUTANT-COEFFS

Specifies the pollutant coefficients for 6 pollutants plus other information needed to allow a simple calculation of pollutant production, both on site and off site, due to the energy consumed by the building. **Not yet implemented.**

Example input:

```
POLLUTANT-COEFFS
LOCATION              = IL
UTILITY-RATE        = ELEC-RATE
ELEC-FRAC-GAS       = 0.05
ELEC-FRAC-COAL      = 0.36
ELEC-FROM COAL      = (200,1.5,.7,.03,.00481,.03) ..
```

The calculation is based upon *pollutant coefficients*. A pollutant coefficient is defined to be the pounds of pollutant produced, per Mbtu of fuel consumed (kg/Mwh for metric input). The program already calculates the Mbtus fuel consumed for the various fuel types as well as the electricity usage. The calculation simply multiplies a pollutant coefficient times the fuel consumption to arrive at the amount of pollutant produced. For this calculation, pollutant coefficients are assumed to depend only on pollutant type, fuel type, and whether the fuel is consumed on-site or offsite. The keywords ON-SITE-GAS, ON-SITE-RES-OIL, ON-SITE-DIST-OIL and ON-SITE-COAL provide the pollutant coefficients for on-site fuel use. The keywords ELEC-FROM-GAS, ELEC-FROM-OIL and ELEC-FROM-COAL give the pollutant coefficients for off-site fuel consumption for electricity generation. The keywords ELEC-FRAC-GAS, ELEC-FRAC-OIL and ELEC-FRAC-COAL are used to apportion the electricity provided to the site by off-site fuel type.

LOCATION

The abbreviation of the name of a state. The abbreviations used are the familiar ZIP code abbreviations (IL is Illinois, CA is California, etc.). PR for Puerto Rico and DC for District of Columbia are also accepted. The location is used to choose correct default values for the pollutant coefficients. This keyword is REQUIRED.

ON-SITE-GAS

List of 6 pollutant coefficients for on site gas usage. The pollutants are (in order of occurrence in the input list): carbon dioxide (CO₂), sulfur dioxide (SO₂), oxides of nitrogen (NOX), carbon monoxide (CO), hydrocarbons (HC), and particulate matter (PM). A pollution coefficient is defined to be the pounds of pollutant produced per MBtu of fuel consumed.

ON-SITE-RES-OIL

List of 6 pollutant coefficients for on site gas usage. The pollutants are (in order of occurrence in the input list): carbon dioxide (CO₂), sulfur dioxide (SO₂), oxides of nitrogen (NOX), carbon monoxide (CO), hydrocarbons (HC), and particulate matter (PM). A pollution coefficient is defined to be the pounds of pollutant produced per MBtu of fuel consumed.

ON-SITE-DIST-OIL

List of 6 pollutant coefficients for on site gas usage. The pollutants are (in order of occurrence in the input list): carbon dioxide (CO₂), sulfur dioxide (SO₂), oxides of nitrogen (NOX), carbon monoxide (CO), hydrocarbons (HC), and particulate matter (PM). A pollution coefficient is defined to be the pounds of pollutant produced per MBtu of fuel consumed.

ON-SITE-COAL

List of 6 pollutant coefficients for on site gas usage. The pollutants are (in order of occurrence in the input list): carbon dioxide (CO₂), sulfur dioxide (SO₂), oxides of nitrogen (NOX), carbon monoxide (CO), hydrocarbons (HC), and particulate matter (PM). A pollution coefficient is defined to be the pounds of pollutant produced per MBtu of fuel consumed.

ELEC-FROM-GAS

List of 6 pollutant coefficients for on site gas usage. The pollutants are (in order of occurrence in the input list): carbon dioxide (CO₂), sulfur dioxide (SO₂), oxides of nitrogen (NOX), carbon monoxide (CO), hydrocarbons (HC), and particulate matter (PM). A pollution coefficient is defined to be the pounds of pollutant produced per MBtu of fuel consumed.

ELEC-FROM-OIL

List of 6 pollutant coefficients for on site gas usage. The pollutants are (in order of occurrence in the input list): carbon dioxide (CO₂), sulfur dioxide (SO₂), oxides of nitrogen (NOX), carbon monoxide (CO), hydrocarbons (HC), and particulate matter (PM). A pollution coefficient is defined to be the pounds of pollutant produced per MBtu of fuel consumed.

ELEC-FROM-COAL

List of 6 pollutant coefficients for on site gas usage. The pollutants are (in order of occurrence in the input list): carbon dioxide (CO₂), sulfur dioxide (SO₂), oxides of nitrogen (NOX), carbon monoxide (CO), hydrocarbons (HC), and particulate matter (PM). A pollution coefficient is defined to be the pounds of pollutant produced per MBtu of fuel consumed.

ELEC-FRAC-GAS

Fraction of off site electricity produced using gas.

ELEC-FRAC-OIL

Fraction of off site electricity produced using oil.

ELEC-FRAC-COAL

Fraction of off site electricity produced using coal.

UTILITY-RATE

The u-name of a utility-rate command. The program uses the time-of-use block-charges in this utility rate to create a report ES-H which shows pollutant production broken down by time-of-use period. This keyword is REQUIRED.

Default Pollution Coefficients by Region

Results based on the defaults should be treated with caution. The defaults for ELEC-FROM-GAS, ELEC-FROM-OIL and ELEC-FROM-COAL may not reflect the resource mix of a local power provider. The regionally based defaults for the SO₂ pollution coefficients may also not reflect local conditions. Lastly, any of the pollution coefficients may depend on factors (such as machine type, operating conditions, etc.) that are not considered in this pollutant production calculation.

Table 49 On-site Pollutant Coefficients

Keyword	CO2 (lb/Mbtu)	SO2 (lb/Mbtu)	NOX (lb/Mbtu)	CO (lb/Mbtu)	HC (lb/Mbtu)	PM (lb/Mbtu)
ON-SITE-GAS	115.	.00059	.137	.034	.00058	.003
ON-SITE-RES-OIL	170	1.04667	.36667	.03333	.008533	.08667
ON-SITE-DIST-OIL	170.	.552817	.140845	.035211	.000408	.014085
ON-SITE-COAL	200.	2.9444	.584	.20856	.00417	.03
ELEC-FROM-GAS	115.	by region	.2	.039078	.001661	.00293
ELEC-FROM-OIL	170.	by region	.3	.033175	.0069	.1
ELEC-FROM-COAL	200.	by region	.7	.02886	.00481	.1
	(kg/Mwh)	(kg/Mwh)	(kg/Mwh)	(kg/Mwh)	(kg/Mwh)	(kg/Mwh)
ON-SITE-GAS	178.	.0091	.212	.053	.00090	.0046
ON-SITE-RES-OIL	263.	1.62035	.56764	.05160	.013210	.13417
ON-SITE-DIST-OIL	263.	.855816	.218042	.054510	.000632	.021805
ON-SITE-COAL	310.	4.5582	.904	.32287	.00646	.046
ELEC-FROM-GAS	178.	by region	.31	.060497	.002571	.00454
ELEC-FROM-OIL	263.	by region	.46	.051358	.0107	.15
ELEC-FROM-COAL	310.	by region	1.1	.04468	.00745	.15

Table 50 SO2 Pollution Coefficients – Off-site defaults by Region (Aggregate of all fuels)

Region	SO2 (lb/Mbtu)	SO2 (kg/Mwh)	States in Region
1	2.5846	4.0012	CT, MA, ME, NH, RI, VT
2	2.19693	3.4010	NJ, NY, PR, VI
3	5.2983	8.2023	DC, DE, MD, PA, VA, WV
4	4.45835	6.9020	AL, FL, GA, KY, MS, NC, SC, TN
5	6.71983	10.4030	IL, IN, MI, MN, OH, WI
6	1.4215	2.2006	AR, LA, NM, OK, TX
7	5.49217	8.5024	IA, KS, MO, NE
8	2.13226	3.3010	CO, MT, ND, SD, UT, WY
9	0.71075	1.1003	AZ, CA, HI, NV
10	0.32307	0.50014	AK, ID, OR, WA

Table 51 Defaults by state for ELEC-FROM-GAS, ELEC-FROM-OIL, and ELEC-FROM-COAL

State	Gas	Oil	Coal	State	Gas	Oil	Coal
AK	0.61	0.09	0.07	MT	0.00	0.00	0.67
AL	0.00	0.00	0.68	NC	0.00	0.00	0.66
AR	0.08	0.00	0.53	ND	0.00	0.00	0.94
AZ	0.05	0.00	0.49	NE	0.01	0.00	0.55
CA	0.48	0.00	0.00	NH	0.53	0.10	0.23
CO	0.01	0.00	0.94	NJ	0.11	0.03	0.17
CT	0.01	0.21	0.09	NM	0.08	0.00	0.91
DC	0.00	1.00	0.00	NV	0.12	0.01	0.77
DE	0.10	0.29	0.61	NY	0.18	0.16	0.22
FL	0.14	0.22	0.45	OH	0.00	0.00	0.89
GA	0.00	0.00	0.64	OK	0.33	0.00	0.60
HI	0.00	1.00	0.00	OR	0.00	0.00	0.10
IA	0.01	0.00	0.85	PA	0.00	0.01	0.62
ID	0.00	0.00	0.00	PR	0.00	1.00	0.00
IL	0.01	0.00	0.40	RI	0.33	0.67	0.00
IN	0.01	0.00	0.98	SC	0.00	0.00	0.33
KS	0.04	0.00	0.70	SD	0.00	0.00	0.41
KY	0.00	0.00	0.95	TN	0.00	0.00	0.68
LA	0.46	0.01	0.35	TX	0.39	0.00	0.49
MA	0.12	0.40	0.33	UT	0.02	0.00	0.95
MD	0.02	0.07	0.60	VA	0.02	0.03	0.46
ME	0.00	0.16	0.00	VT	0.03	0.00	0.00
MI	0.01	0.01	0.75	WA	0.01	0.00	0.12
MN	0.01	0.02	0.62	WI	0.00	0.00	0.71
MO	0.00	0.00	0.84	WV	0.00	0.00	0.99
MS	0.21	0.02	0.39	WY	0.00	0.00	0.98

RATCHET

Allows a utility ratchet to be defined. RATCHET's can be specified in both the UTILITY-RATE and the BLOCK-CHARGE commands. There are important differences in the effect a RATCHET has on the billing demands when specified at these two different levels:

When specified at the BLOCK-CHARGE level, the ratchet(s) are used in the billing demand calculation for that BLOCK-CHARGE only; the ratchet does not affect any other BLOCK-CHARGE, nor does it affect its parent UTILITY-RATE.

When specified at the UTILITY-RATE level, the ratchet(s) are used in the billing demand calculation for the UTILITY-RATE. They also apply to any associate BLOCK-CHARGE's of the UTILITY-RATE, provided the BLOCK-CHARGE does not have any of its own ratchets specified.

Discussion of RATCHET:

Defines demand ratchets to be used in calculating billing demands. These ratchets can be referenced by both the UTILITY-RATE and BLOCK-CHARGE commands. The time period over which the RATCHET is calculated is defined by a schedule, and more than one RATCHET can be used to establish a billing demand. RATCHET's take the hourly metered values as calculated in the parent UTILITY-RATE and determine a peak quantity for each billing period. If a schedule is specified, the RATCHET may compute the demand for a specific season, such as summer, or for a particular time period, such as on-peak or off-peak. The ratchet may include a sliding window (such as the maximum demand over the last 3 months). In addition, the ratcheted demand may be adjusted by an offset or multiplied by a fraction. A value is calculated for each billing period for use in associated UTILITY-RATE's and BLOCK-CHARGE's. When a RATCHET is defined with a length of one month, the ratcheted value is substituted for the actual monthly demand. This allows calculations to be made for monthly billing demands defined in formats such as \$5.00 per kW for 80% of all kW above the first 20kW. Multiple ratchets can be defined for charges such as the actual monthly demand, 50% of the peak winter demand, or 80% of the peak summer demand, whichever is the largest.

In addition, by default, a BLOCK-CHARGE associated with the UTILITY-RATE will also use those ratchet(s), provided that no ratchets are explicitly listed in the BLOCK-CHARGE command. If ratchets are listed in the BLOCK-CHARGE command, then the UTILITY-RATE ratchets will be disregarded. In this fashion, ratchets may act globally (at the UTILITY-RATE level), or locally (at the BLOCK-CHARGE level). These rules are reflected in reports ES-E (for the UTILITY-RATE) and ES-F (for the BLOCK-CHARGE's). Report ES-E displays the billing demand for the UTILITY-RATE. This billing demand will not include any ratchets defined in one or more BLOCK-CHARGE's, only the UTILITY-RATE ratchets. The billing demands for each BLOCK-CHARGE listed in report ES-F will include any local ratchets. If no local ratchets are defined, then any UTILITY-RATE ratchets defined will be used. For example, when a utility uses the same RATCHET for both summer and winter BLOCK-CHARGE's (either kWh/kW or demand blocks), the RATCHET's should be specified in the UTILITY-RATE command so that they can be globally used by all associated BLOCK-CHARGE's. In this case, it is not necessary to specify any RATCHET's directly in the BLOCK-CHARGE commands. If, however, different RATCHET's apply to the summer and winter BLOCK-CHARGE's, then the RATCHET's should be specified at the BLOCK-CHARGE level and not in the UTILITY-RATE.

Example input:

```
"50% Ratchet" = RATCHET
  NUM-MONTHS      = 12
  FRACTION         = 0.5
  ..
```

NUM-MONTHS

Specifies the period over which the ratchet is calculated; default is 12. A value of 1 implies the ratchet is to be calculated on the basis of the current month only; the current month's peak will have no impact on subsequent months. When this type of ratchet is used, the current month's peak is ignored, and the ratchet value is used in its place. In this case, the demand is usually adjusted by an OFFSET and/or FRACTION, defined below, so that the billing demand for the current month is an adjusted demand rather than the peak demand. A value of 2 to 11 specifies the number of months that will be used in calculating a sliding ratchet. For example, if the current month's billing demand is the maximum of this month's peak, or the peak in any of the 3 previous months, this value should be set to 4. A value of 12 implies that the ratchet will be calculated over all months of the year. The maximum demand encountered during the year will be the basis of the ratchet.

RATCHET-SCH

U-name for a SCHEDULE which defines the period over which the ratchet will be calculated. If not specified, the ratchet is assumed to be active all hours. This keyword is useful when one ratchet applies to winter demand, and a different ratchet to summer demand. On-peak/off-peak ratchets can also be defined. The ratcheted demand will be the maximum demand encountered during the scheduled period. If NUM-MONTHS is less than the period defined in the RATCHET-SCH, then a sliding ratchet will occur during the scheduled period. For example, assume RATCHET-SCH is defined to be active from April through October, and NUM-MONTHS is 4. If the current month is June, then the billing demand will be the maximum of the current month's peak, May's, April's, or October's.

SCH-FLAG

Specifies the flag value in the RATCHET-SCH that indicates when this ratchet is active.

TYPE

Accepts a code-word that identifies how the demand is calculated in this ratchet.

HIGHEST-PEAK	The default, causes the RATCHET to be calculated on the basis of the highest monthly peak of the ratchet period.
AVERAGE	Causes the RATCHET to be calculated on the basis of the average of the monthly peaks of the ratchet period. Note that when NUM-MONTHS is one, HIGHEST and AVERAGE give the same result.

OFFSET

Accepts a numeric value between -1,000,000 and 1,000,000 that is added to the demand. The default is 0.0. OFFSET, if used, is typically negative so that the value of the ratcheted demand is reduced. The adjusted ratcheted demand is limited to be not less than 0.0. When NUM-MONTHS is 1, a negative value for OFFSET effectively creates a threshold below which no demand charges will be calculated.

FRACTION

Accepts a numeric value between 0.0 and 1.0 that is multiplied against the demand. The demand is adjusted by the OFFSET before FRACTION is applied. The adjusted demand is:

$$\text{Adj. Demand} = (\text{Peak Demand} - \text{OFFSET}) * \text{FRACTION}$$

This adjusted demand is used in place of the peak demand for each month in the RATCHET period.

UTILITY-RATE

This command contains the most basic features of a tariff: units, uniform energy and demand cost rates, reactive demands, monthly charges, minimum charges, taxes, etc. One UTILITY-RATE command is entered for each type of energy or fuel used in the previous PLANT run. When more than one rate is used for an energy type, or the specific rate that will apply is not known, more than one UTILITY-RATE may be defined. UTILITY-RATE also allows costs to be defined for energy that varies by time, but not by quantity. For charges that vary by quantity, such as blocks of energy with different costs, this command references one or more BLOCK-CHARGE commands. When energy is billed in a time-of-use format a UTILITY-RATE keyword accepts the u-name of a schedule which defines these charges for the entire year. Time-of-use demand charges are more complicated and must be defined using the BLOCK-CHARGE command. On an hourly basis, each UTILITY-RATE defined in ECONOMICS sums the energy from the specified meters and accumulates the data into total and peak values for each billing period. If a time-of-use energy charge schedule has been defined, the hourly values are multiplied by the scheduled value and summed for the billing period. The UTILITY-RATE also passes the hourly data to the associated BLOCK-CHARGES and RATCHETS. During each billing cycle, UTILITY-RATE adjusts the metered energy and demand values for any minimum quantities required and adjusts demands by any RATCHETS specified. These adjusted billing quantities are then used as the basis for the energy cost calculations. Block costs computed by any associated BLOCK-CHARGES are then added. The costs are then adjusted by any minimum monthly charges and/or rate limitations. Applicable taxes and surcharges are then computed and added to the total. It is possible to define more than one UTILITY-RATE for the same resource or meters, and allow the program to select the correct rate to use on the basis of qualifiers you define. These qualifiers include minimum and maximum energy and demand quantities for each billing period, and also a schedule. You can also specify whether the same UTILITY-RATE must be used all year, or whether UTILITY-RATES can be switched during the course of the year.

U-name required so that each rate can be listed in the summary reports. Up to 15 different UTILITY-RATES may be defined.

Example input:

```
"TOU-8 Electric Rate" = UTILITY-RATE
  TYPE                = ELECTRICITY
  ELEC-METERS         = ( "EM20" )
  MONTH-CHGS         = ( 359.45 )
  BLOCK-CHARGES      = ( "Win OffPeak", "Win MidPeak",
                        "Sum OffPeak", "Sum MidPeak", "Sum Peak",
                        "24-Hour Demand" )
  RATE-LIMITATION    = 0.20549
  ..

"Gas Rate"= UTILITY-RATE
  TYPE                = NATURAL-GAS
  FUEL-METERS         = ( "FM20" )
  ENERGY-CHG        = 0.5
  ..
```

TYPE

Specifies the type of meter this UTILITY-RATE will accept. :

STEAM	specifies that the meter(s) will be steam.
CHILLED-WATER	specifies that the meter(s) will be chilled-water.
ELECTRICITY	specifies an utility-rate through which power is normally sold to a facility.

If a facility has generators that produce more power than can be consumed on-site, and the output of those generators is attached to an ELEC-METER associated with this UTILITY-RATE, then the BUY/SELL-MODE will determine whether the utility will give credit for running the meter backwards. If allowed, energy costs may be either positive or negative on an hourly basis. However, the peak consumption used in calculating the demand charge is never less than zero, even if the facility is a net producer of power all hours. To calculate a rate that includes demand credits for surplus power, use a utility-rate of type ELECTRIC-SALE.

ELECTRIC-SALE	specifies a rate through which power is sold back to a utility. This type of rate can compute both energy and demand credits for the power sold, and can include complex block-charge and/or ratchet structures. Refer to the section on Buy/Sell Arrangements for more information on sales of power to a utility.
NATURAL-GAS	specifies that the meter(s) will be natural gas.
LPG	specifies that the meter(s) will be liquified petroleum gas.
FUEL-OIL	specifies that the meter(s) will be fuel oil.
DIESEL-OIL	specifies that the meter(s) will be diesel oil.
COAL	specifies that the meter(s) will be coal.
METHANOL	specifies that the meter(s) will be methanol.
OTHER-FUEL	specifies that the meter(s) will be another type of fuel as specified in the FUEL-METER command.

The program will check to ensure that different meters are not mixed within the same UTILITY-RATE. For example, an electric meter cannot be mixed with a natural gas meter. Nor can a natural gas meter be mixed with a coal meter.

ELEC-METERS

When TYPE = ELECTRICITY, accepts a list of electric meters for which this UTILITY-RATE will calculate costs.

FUEL-METERS

When TYPE = NATURAL-GAS, LPG, FUEL-OIL, DIESEL-OIL, COAL, METHANOL, or OTHER-FUEL, accepts a list of the fuel meters for which this UTILITY-RATE will calculate costs. The program will check to make sure that different fuels are not mixed in the same UTILITY-RATE.

STEAM-METERS

When TYPE = STEAM, accepts a list of steam meters for which this UTILITY-RATE will calculate costs.

CHW-METERS

When TYPE = CHILLED-WATER, accepts a list of chilled water meters for which this UTILITY-RATE will calculate costs.

BILLING-DAYS

Accepts a list in parentheses of up to 12 values. If you input less than 12, the last value entered will be the default for all unentered values. All costs, etc. reported in output reports will be based on the billing-day. For example, if the billing-day is 17, energy usage for each month listed in the reports will be from the 18th day of the previous month, through the 17th day of the current month. You may elect to explicitly enter the billing day for each month when it is desired to closely match existing utility bills. This may be important if the meter is not regularly read on the same day each month.

Rate Qualifiers

The following keywords are qualifiers used to define whether and how this UTILITY-RATE will be used as monthly energy and demand varies through out the simulation period. Based on total and/or peak consumption, the qualifiers can be used to determine whether a particular UTILITY-RATE is used in place of another. In addition, the qualifiers can set the minimum contract billing quantities for energy and demand.

Most commonly, the qualifiers will determine which rate is used for the entire simulation period. This is useful if a utility has several rates, one of which will be selected on the basis of peak annual demand or other criteria, and you do not yet know what the predicted energy consumption is. In this case, you may enter all of the rates, together with the appropriate qualifiers, and allow the program to select the applicable rate.

Less commonly, you may allow the program to switch from one utility rate to another on the basis of qualifiers which may vary monthly.

ENERGY-QUALS

Designates a list of the (Minimum, Maximum) monthly energy usages that qualify this rate. These qualifiers will be used to select whether this UTILITY-RATE will be used in place of another. Alternately, the minimum can be used to establish a minimum quantity of energy that will be billed (see USE-MIN-QUALS).

If a value of 0.0 is listed for the maximum, then there is no maximum qualifier. If both ENERGY-QUALS and DEMAND-QUALS are defined, the rate must qualify on the basis of both.

DEMAND-QUALS

Designates a list of the (Minimum, Maximum) monthly demands that qualify this rate. These qualifiers will be used to select whether this UTILITY-RATE will be used in place of another. Alternately, the minimum can be used to establish a minimum demand that will be billed (see USE-MIN-QUALS).

If a value of 0.0 is listed for the maximum, then there is no maximum qualifier. If both ENERGY-QUALS and DEMAND-QUALS are defined, the rate must qualify on the basis of both.

QUAL-SCH

U-name of a schedule which defines the period(s) during which this UTILITY-RATE will be used. This keyword will usually be used only when there are METERS that must be associated with different rates on a seasonal basis. QUAL-SCH, if specified, will determine the months during which the above qualification parameters will be tested.

For example, chiller energy may be broken out separately during the summer to take advantage of a favorable thermal energy storage rate offered only during the summer. All other times of the year, chiller energy is grouped with all other energy end uses. UTILITY-RATEs cannot be switched in the middle of a billing period; therefore, the program evaluates the value of the schedule only during the first hour of the BILLING-DAYS. All other schedule values are ignored.

SCH-FLAG

When QUAL-SCH is specified, specifies the flag value in the schedule that will activate this utility rate. The default is 1.0. Refer to the discussions in the Basics and *DOE-2.2 Topics* for more information on the use of flag values.

USE-MIN-QUALS

Keywords ENERGY-QUALS, DEMAND-QUALS, USE-MIN-QUALS, QUALIFY-RATE, and QUAL-SCH are qualifiers used to define whether and how this UTILITY-RATE will be used as monthly energy and demand varies through out the simulation period. Based on total and/or peak consumption, the qualifiers can be used to determine whether a particular UTILITY-RATE is used in place of another. In addition, the qualifiers can set the minimum contract billing quantities for energy and demand.

YES	Energy and demand charges will be calculated on the basis of the greater of either the actual monthly energy and demand charges, or the minimum amounts specified under ENERGY-QUALS and DEMAND-QUALS keywords above.
NO	The default; there is no minimum charge calculation for either energy or demand.

QUALIFY-RATE

Defines how the ENERGY-QUALS and DEMAND-QUALS are used in determining whether the UTILITY-RATE will be used. Keywords ENERGY-QUALS, DEMAND-QUALS, USE-MIN-QUALS, QUALIFY-RATE, and QUAL-SCH are qualifiers used to define whether and how this UTILITY-RATE will be used as monthly energy and demand varies through out the simulation period. Based on total and/or peak consumption, the qualifiers can be used to determine whether a particular UTILITY-RATE is used in place of another. In addition, the qualifiers can set the minimum contract billing quantities for energy and demand.

ALL-MONTHS	Default, means this UTILITY-RATE will be used all months of the year, regardless of the values of ENERGY-QUALS and DEMAND-QUALS. If ALL-MONTHS is not specified, it is assumed that you will specify other UTILITY-RATEs having appropriate qualifiers to cover all circumstances. If not, the output reports may show zero costs some months and report ES-D will include a warning message.
ONE-MONTH-MIN	Implies that the usage in at least one month must exceed either the energy or demand minimum as specified in ENERGY-QUALS and DEMAND-QUALS. Either the energy or demand minimum limit must be exceeded to qualify for this rate, but both do not. In addition, no month may exceed the maximum energy or demand qualifiers. As described previously, an entry of 0.0 for the maximum value causes the maximum limits to be disregarded.
ALL-MONTHS-MIN	Implies that the usage in every month must exceed both the energy and demand minimum specified in the ENERGY-QUALS and DEMAND-QUALS. Both minimums must be exceeded to qualify for this rate. In addition, at least one month must be under the maximum energy or demand qualifiers. As described previously, an entry of 0.0 for the maximum value causes the maximum limits to be disregarded.
MONTH-BY-MONTH	Implies that this rate will be used any month that both the energy and demand minimums are exceeded as specified in ENERGY-QUALS and DEMAND-QUALS, and neither maximum is exceeded. Note that this implies that rates can be switched on a monthly basis, this is not usually the case.

Energy and Demand Charges

The following keywords define the monthly customer, energy, and demand charges. Energy charges here may be either fixed or vary according to a time-of-use schedule. Demand charges are based on a single monthly value that may be adjusted by one or more RATCHETS.

Most electric utilities use relatively complex block structures for energy and/or demand. You define these block structures separately using or more BLOCK-CHARGE_s, and then linking the blocks to the utility rate.

MONTH-CHGS

Accepts a list in parentheses of up to 12 numeric values that add a fixed monthly charge to each billing cycle. Many utilities refer to this as a customer charge. If a single value is entered, the value will be used for all 12 billing periods. If fewer than 12 are entered, the last value entered will be used for all remaining billing periods. This is true of all numeric lists in ECONOMICS.

ENERGY-CHG

Accepts a numeric value that allows you to specify an energy charge that is constant with time and quantity. The units are \$/UNIT. In the absence of any other charges, this keyword will default in accordance with Table 52. The UNIT value is the unit as defined or defaulted in the ENERGY-RESOURCE command of PLANT.

Table 52 Default ENERGY-CHG Values for UTILITY-RATE

RESOURCE	VALUE	\$/UNIT
CHILLED-WATER	12,000 Btu/ton	0.12
COAL	24,580,000 Btu/ton	30.00
DIESEL-OIL	138,700 Btu/gal	1.05
ELEC-BUY/SELL	3,412.97 Btu/kWh	0.05
ELEC-NET-SALE	3,412.97 Btu/kWh	0.05
ELECTRICITY	3,412.97 Btu/kWh	0.07
FUEL-OIL	138,700 Btu/gal	1.19
LPG	95,500 Btu/gal	0.97
METHANOL	63,500 Btu/gal	1.13
NATURAL-GAS	100,000 Btu/therm	0.50
OTHER-FUEL	1,000,000 Btu/unit	0.95
STEAM	1,000,000 Btu/unit	13.00

ENERGY-CHG-SCH

U-name of a SCHEDULE which specifies an ENERGY-CHG that varies by time of day, week and/or season. The units in the schedule should be \$/UNIT. This schedule is used for all time-of-use energy billing (demand time-of-use billing is more complex, and requires the use of multiple BLOCK-CHARGE_s). If both an ENERGY-CHG and ENERGY-CHG-SCH are defined, the values will add.

ENERGY-COST-ADJS

Accepts a list in parentheses of 12 values that specify an energy cost adjustment factor for each billing period. These factors have units of \$/UNIT and default to \$0.0/UNIT. If less than 12 values are entered, the last value entered will be used for all remaining billing periods. The total monthly energy usage is multiplied by this factor and the sum

is added to all other energy costs. It is assumed that energy cost adjustments will be in addition to any minimum charges defined, and are not subject to the RATE-LIMITATION, if specified.

ENERGY-ADJ-SCH

U-name of a SCHEDULE which specifies an ENERGY-COST-ADJS that varies by time of day, work and/or season. The units in the schedule should be \$/UNIT.

DEMAND-CHGS

Accepts a list in parentheses of 12 values that allows you to specify a demand charge that is constant with quantity but may vary by billing period. The units are \$/peak-UNIT and can range from \$0.0 to \$100,000,000/peak-UNIT. As with other lists, as few as one value may be entered in the list, and the last value will be used for the remaining billing periods. The billing demand will be based on the largest of: 1. The actual monthly demand; or 2. A RATCHET(s) demand, if defined; or 3. The minimum DEMAND-QUALS. For DEMAND-QUALS to be used, it must be specified and USE-MIN-QUALS must be YES.

DEMAND-WINDOW

Code-word determines the window in which the peak demand is calculated:

FIXED	Default, specifies a demand window that starts at the beginning of the hour, and is DEMAND-INTERVAL long. After this fixed interval of time passes, the window clears and starts recounting, starting at the end of the previous interval
SLIDING	Specifies a window of DEMAND-INTERVAL long that continuously slides from one minute to the next, and from one hour into the next. The window continuously counts; as a new minute's consumption is added, the oldest minute's consumption is dropped..

The DEMAND-WINDOW will be used for all demand calculations, including demands calculated in associated BLOCK-CHARGEs and RATCHETs.

DEMAND-INTERVAL

Accepts a numeric entry specifying the size in minutes of the DEMAND-WINDOW. The default is 15 minutes for electric meters, and 60 minutes for all other meters (intervals less than 60 minutes for non-electric meters are disregarded). For electric meters, this entry must be in multiples of 5 minutes; the program will round down any other entry to a multiple of 5 minutes (12 minutes will be treated the same as 10 minutes).

The entry should be consistent with the type of DEMAND-WINDOW. For SLIDING windows, any entry is acceptable (5, 10, 15, 20, 25, etc.). For FIXED windows, the entry must allow an even number of intervals to exactly fit within the hour (5, 10, 15, 20, 30, 60).

An entry longer than 60 minutes is acceptable, but is regarded as a flag indicating a 24 hour (daily) demand. This is useful for when demand is charged on the basis of peak daily consumption rather than peak hourly or subhourly consumption.

This is true for some gas and steam utilities. The DEMAND-WINDOW will be used for all demand calculations, including demands calculated in associated BLOCK-CHARGEs and RATCHETs.

DEMAND-RATCHETS

Accepts a list in parentheses of up to five u-names of RATCHETs. These ratchets will be used to modify the billing demands for all demand charges. When RATCHETs are listed, the billing demand will be the larger of: 1. The actual monthly demand; or 2. A RATCHET(s) demand, if defined; or 3. The minimum DEMAND-QUALS. For DEMAND-QUALS to be used, it must be specified and USE-MIN-QUALS must be YES.

BLOCK-CHARGES

Accepts a list in parentheses of up to 10 u-names of BLOCK-CHARGES. These BLOCK-CHARGES can be used to calculate either energy or demand charges that vary according to quantity. In addition, time-of-use demand charges are calculated using the BLOCK-CHARGE format.

POWER-FACTOR

Fraction of peak kVA that is due to real power. Reactive demand is calculated:

$$\text{kVAR} = (\text{Real kW}) / \text{PF} * \text{SIN}(\text{COS}^{-1}(\text{PF}))$$

where (Real kW) is the demand calculated by the program. Note that the program calculates kW only, so that all reactive demands and charges are rough approximations.

EXCESS-KVAR-FRAC

Specifies the fraction of real kW above which a charge is levied on kVAR. If the excess reactive fraction is ER:

$$\text{Excess kVAR} = (\text{Real kW}) * (\text{SIN}(\text{COS}^{-1}(\text{PF})) / \text{PF} - \text{ER})$$

Given the defaults of PF = 0.8 and ER = 0.9, there will be no excess reactive demand.

EXCESS-KVAR-CHG

The charge in \$/kVAR for excess reactive demand.

ESCALATION

Accepts a numeric input in percent that specifies the annual rate of real escalation (relative to the general inflation rate) to be used in life-cycle cost calculations.

MIN-MON-CHGS

Accepts a list in parentheses of 12 values that place a floor on the cost of a fuel or utility for each billing period in which costs are calculated. As with other lists, not all 12 values need be entered; the last value entered will be used for all remaining billing periods. Note that the minimum charge excludes any customer charge, taxes, surcharges, or energy cost adjustments.

MIN-MON-DEM-CHGS

Accepts a list in parentheses of up to 12 values that specify a variable minimum monthly charge calculated on the basis of billing demand. The value entered has units of \$/kW, and the default is 0. The billing demand is the largest of: 1. The actual monthly demand; or 2. A RATCHET(s) demand, if defined; or 3. The minimum DEMAND-QUAL. For DEMAND-QUALS to be used, it must be specified and USE-MIN-QUALS must be YES. Some utilities do not charge directly for demand, but embed demand charges in kWh/kW rate structures. This keyword allows demand charges to be levied in the event actual demand is exceptionally high relative to total energy use. The total minimum month charges will be the sum of the constant and variable minimum charges as specified by MIN-MON-CHGs and MIN-MON-DEM-CHGs.

MIN-MON-RATCHETS

Specifies a list in parentheses of up to five u-named RATCHETs. The defaults are the ratchets listed in DEMAND-RATCHETS. When MIN-MON-RATCHET(s) are listed, these ratchets will be used in determining the demand for the MIN-MON-DEM-CHGS.

RATE-LIMITATION

Accepts a numeric value in dollars per unit that places a ceiling on the maximum effective rate that will be assessed on a utility or fuel for any month. The RATE-LIMITATION excludes MONTH-CHGs and charges arising from

ENERGY-COST-ADJUSTMENTS. In addition, the RATE-LIMITATION cannot cause the total bill to drop below the fixed MIN-MON-CHGs plus the MIN-MON-DEM-CHGs.

Taxes and Surcharges

The following keywords define how taxes and surcharges are levied. In general, both taxes and surcharges may be levied on a percentage basis of dollar charges, or by unit of energy consumed. Taxes and surcharges may be either on a flat rate basis, or in a progressive structure where the charges vary based on the total amount.

PCT-TAX-BLOCKS

accepts a list in parenthesis of the maximum size of the block of money upon which a tax will be levied (up to 3 total). When a utility uses a progressive tax structure, the second and third entries define the successive money blocks upon which the tax will be levied.

PCT-TAXES

accepts a list of the taxes (in percent) corresponding to the blocks of money entered for PCT-TAX-BLOCKS.

Example input: A municipality charges a tax of 5% on the first \$1000 of charges, 4% on the next \$5000 and 2% on all remaining charges. Acceptable input could be:

```
PCT-TAX-BLOCKS    = ( 1000 , 5000 , 1 )
PCT-TAXES         = (   5 ,    4 , 2 )
```

Note that the value of the last block quantity may be set to any value as all remaining charges will be taxed at the rate of the last set entered.

PCT-TAXES-APPLY

Accepts a list in parentheses of up to three code-words that specify which charges are taxed. The code-words are:

BASE	Energy cost adjustments and surcharges are not taxed. Includes all customer, energy and demand charges, including charges in associated BLOCK-CHARGES.
ECA	Energy cost adjustments are taxed.
SURCHARGES	Surcharges are taxed.

UNIT-TAX-BLOCKS

Accepts a list in parenthesis of the maximum size of the energy usage block upon which a tax is levied on a per-unit-of-energy basis. For example, for natural gas billed in therms, the tax will be on a per therm basis.

UNIT-TAXES

Accepts a list in parenthesis of the tax in dollars/unit corresponding to UNIT-TAX-BLOCKS. The use of UNIT-TAX-BLOCKS and UNIT-TAXES is identical to PCT-TAX-BLOCKS and PCT-TAXES, except that the tax is levied on the units of energy consumed rather than on the cost of that energy.

PCT-SRCHG-BLOCKS

Accepts a list in parentheses of the maximum size of the block of money upon which a surcharge is levied on a percentage basis.

PCT-SRCHGS

Accepts a list of the surcharges (in percent) corresponding to the blocks of money entered for PCT-SRG-BLOCKS. The use of PCT-SRG-BLOCKS and PCT-SRCHGS is identical to PCT-TAX-BLOCKS and PCT-TAXES.

PCT-SRCHGS-APPLY

Accepts a list in parentheses of up to three code-words which specify which charges are assessed. The code-words are:

BASE	Energy cost adjustments and surcharges are not taxed. Includes all customer, energy and demand charges, including charges in associated BLOCK-CHARGES.
ECA	The surcharges apply to energy cost adjustments.
TAXES	The surcharge apply to taxes. The program assumes that if percent surcharges are levied on percent taxes, that percent taxes will not also be levied on percent surcharges.

UNIT-SRCHG-BLOCKS

Accepts a list in parenthesis of the maximum size of the energy usage block upon which a surcharge is levied on a per unit of energy basis. For example, for natural gas billed in therms, the surcharge will be on a per therm basis.

UNIT-SRCHGS

Accepts a list in parenthesis of the surcharge in dollars/unit corresponding to the UNIT-SRCHG-BLOCKS. The use of UNIT-SRCHG-BLOCKS and UNIT-SRCHGS is identical to PCT-TAX-BLOCKS and PCT-TAXES, except that the surcharge is levied on the units of energy consumed rather than on the cost of that energy.

Buy/Sell Arrangements

When a facility has on-site ELEC-GENERATOR(s), the generator output may be either consumed on-site, or sold back to the utility. It is also possible for the generator output to be preferentially consumed on-site, with only the surplus sold back to the utility.

There are two options available for selling power back to a utility:

If electric power is bought and sold at different rates, then at least two ELEC-METERs must be defined, one of type UTILITY and the other of type ELECTRIC-SALE. All facility demands attach to the UTILITY meter, and the generator attaches to the ELECTRIC-SALE meter. Two UTILITY-RATES must also be defined, one of type ELECTRICITY and the other of type ELECTRIC-SALE, and the appropriate meters attached to each.

Note that, if generator power is to be preferentially consumed on-site with only the surplus sold, then the generator attaches to both the UTILITY meter via its ELEC-METER keyword, and to the ELECTRIC-SALE meter via its SURPLUS-METER keyword. Please refer to the ELEC-GENERATOR and cogeneration discussions for more information and examples.

If electric power is bought and sold at the same rate, and the utility allows a single meter to "run backwards" during times of surplus power generation, then only one ELEC-METER of type UTILITY is required. All facility demands attach to this meter, as well as the generator.

During hours when the facility is a net consumer of power, energy and demand charges accrue normally on the net consumption in accordance with the UTILITY-RATE. During hours when the facility is a net producer of power, energy charges are credited at the current rate, which may be a time-

of-use rate. However, demand charges are never credited when a meter is running backwards. In other words, while energy costs may be either positive or negative on an hourly basis, the peak consumption used in calculating the demand charge is never less than zero, even if the facility is a net producer of power all hours.

Facilities with large cogeneration plants typically buy and sell power at different rates, and utilize the two-meter configuration. Residential and small commercial facilities with photovoltaic systems typically use the one-meter configuration, and may run the meter backwards during peak production. The utility will usually give credit for power fed back into the grid, but will typically restrict the credit to be not more than the energy consumed on either a monthly or yearly basis. In other words, if a facility produces more power than it consumes on an annual basis, no credit will accrue for the net annual surplus. However, while the utility will not pay for a net annual surplus, it will waive all customer charges and any demand charges that may have accrued during times the facility was a net power consumer.

Utilities normally allow meters to run backwards only if they use relatively simple UTILITY-RATEs, and this is true in this program as well. The program can model simple energy/demand charge structures, including time-of-use structures, with the meter running backwards for a month or more. However, more complex structures have not been tested in this mode, and the program may break down if a rate with complex BLOCK-CHARGES, particularly demand-dependent block charges, is run backwards for an entire month.

For example, assume a BLOCK-CHARGE is defined having a KWH/KW structure, and the facility is a net producer of power all hours for an entire month. In this case, the structure will calculate charges for a negative monthly kWh, and zero kW. The results may be quite unreliable! (This comment applies only to UTILITY-RATES of type ELECTRICITY that are run backwards; it does not apply to ELECTRIC-SALE utility rates, which can reliably calculate both energy and demand credits.)

The following keywords are applicable to buy/sell arrangements. For clarity, some are repeated from above.

TYPE

accepts a code-word specifying the type of UTILITY-RATE. Only the types with new meanings are discussed here. All other types (STEAM, CHILLED-WATER, NATURAL-GAS, etc.) are unchanged.

ELECTRICITY specifies an utility-rate through which power is normally sold to a facility.

If a facility has generators that produce more power than can be consumed on-site, and the output of those generators is attached to an ELEC-METER associated with this UTILITY-RATE, then the BUY/SELL-MODE will determine whether the utility will give credit for running the meter backwards. If allowed, energy costs may be either positive or negative on an hourly basis. However, the peak consumption used in calculating the demand charge is never less than zero, even if the facility is a net producer of power all hours. To calculate a rate that includes demand credits for surplus power, use a utility-rate of type ELECTRIC-SALE.

ELECTRIC-SALE specifies a rate through which power is sold back to a utility. This type of rate can compute both energy and demand credits for the power sold, and can include complex block-charge and/or ratchet structures.

ELEC-METERS

when TYPE = ELECTRICITY, accepts a list of ELEC-METERs for which this utility-rate will calculate costs. The electric meters may be of any type: UTILITY, BUILDING, SUB-METER, and/or ELECTRIC-SALE. Note that

the energy associated with ELECTRIC-SALE meter is negative, and may force the utility-rate to calculate cost credits.

ELEC-SALE-METERS

when TYPE = ELECTRIC-SALE, accepts a list of ELEC-METERS for which this utility will calculate cost credits. This type of utility-rate accepts only electric meters of type ELECTRIC-SALE.

BUY/SELL-MODE

when TYPE = ELECTRICITY, and surplus on-site electric generation may force the meter to "run backwards", specifies the allowable buy/sell arrangement with the utility:

BUY/SELL	the default, allows an unlimited amount of surplus power to be sold back to the utility and credited to the customer.
BUY-ONLY	specifies that, while the utility will accept the surplus power, they will not give any credit for it.
NET-MONTHLY	specifies that, on a monthly basis, the utility will accept and credit surplus power, up to the amount actually sold to the facility. In other words, the utility will act as a "bank" and will store surplus power for use by the facility, provided the surplus is consumed within the same month it is produced. If, on a monthly basis, the facility is a net producer of power (sells more than it buys), the utility will accept the excess production, but will not pay for it, and will not apply it toward future months. Instead, depending on the NET-SALE-CREDITS, the utility may waive all monthly costs, including customer charges and demand charges that accrued during hours the facility was a net power consumer.
NET-YEARLY	specifies that, on a yearly basis, the utility will accept and credit surplus power, up to the amount actually sold to the facility. In other words, the utility will act as a "bank" and will store surplus power for use by the facility, provided the surplus is consumed within the same year it is produced. If, on a yearly basis, the facility is a net producer of power (sells more than it buys), the utility will accept the excess production, but will not pay for it. Instead, depending on the NET-SALE-CREDITS, the utility may waive all yearly costs, including customer charges and demand charges that accrued during hours the facility was a net power consumer.

NET-SALE-CREDITS

when BUY/SELL-MODE is NET-MONTHLY or NET-YEARLY, specifies the types of credits that will be given for power sold back to the utility:

ENERGY-ONLY	the default, specifies that only energy sales will be credited, up to the amount of energy bought. Any demand and/or fixed costs will still be charged.
ENERGY&DEMAND	specifies that both energy and demand charges will be credited, up to the amount of energy bought. Demand charges are not actually credited, but instead are "forgiven" whenever the facility is a net power producer for the monthly or yearly interval. Fixed costs are still charged.
ALL-COSTS	specifies that all monthly charges, including fixed charges are dropped whenever the facility is a net power producer for the monthly or yearly interval.

Example Input: Small Commercial Photovoltaic System

A small commercial building has a roof-mounted photovoltaic array. The building uses a single meter, which is allowed to "run backwards" during periods of surplus power production. The utility has a net-sale arrangement that, on a yearly basis, allows surplus power to be credited toward the power consumed.

```

$ Force the inverter to operate at full output all hours.
$ Otherwise, it will track the building consumption

"EM1" = ELEC-METER
TYPE                = UTILITY
SOURCE-SITE-EFF     = 0.37
COGEN-TRACK-MODE    = MAX-OUTPUT
..

$ Define a single PV module. The actual number will be
$ allowed to default to the inverter capacity

"500W Module" = PV-MODULE
TYPE                = A-SI
SIM-ALGORITHM       = MODIFIED-STANDARD
HEIGHT              = 6.2
WIDTH               = 4.21
GLAZING-TYPE        = SMOOTH
NOM-OPER-CELL-T     = 122.
VOLTS-OPEN-CKT     = 62.
AMPS-SHORT-CKT     = 6.2
VOLTS-MAX-PWR       = 75.0           $ Max-Pwr Volts*Amps
AMPS-MAX-PWR        = 6.67          $ equals rated watts
VOLTS/T-OPEN-CKT   = -0.1267
AMPS/T-SHORT-CKT   = 0.00344
..

$ Define the inverter. The number of series and parallel
$ PV modules attached to this inverter will default
$ according to the inverter capacity and DC voltage
$ requirement.
$ Surplus power will spin the meter backwards because
$ the utility rate allows it

"Free-standing PV Array" = ELEC-GENERATOR
TYPE                = PV-ARRAY
CAPACITY            = 25.           $ kW
MIN-OPER-VOLTS     = 250.
MIN-TRACK-VOLTS    = 330.
MAX-TRACK-VOLTS    = 600.
AUX-KW              = 0.015
AUX-MODE            = ALWAYS
NUM-INVERTERS       = 2
INVERTER-CTRL      = RUN-NEEDED
PV-MODULE           = "500W Module"
MOUNT-TYPE          = RACK
MOUNT-AZIMUTH       = 180.
MOUNT-TILT          = 45.
ELEC-METER          = "EM1"
..

```

In this rate, all charges will be waived if the facility is a net power producer on a yearly basis. Otherwise, surplus power will be credited toward energy costs, but demand charges will apply to all electricity bought

```
"Simple Rate" = UTILITY-RATE
TYPE           = ELECTRICITY
ELEC-METERS    = ( "EM1" )
MONTH-CHGS     = ( 15.00 )
ENERGY-CHG     = ( 0.05 )
DEMAND-CHGS    = ( 2,2,2,2,5,5,
                  5,5,5,2,2,2 )
BUY/SELL-MODE  = NET-YEARLY
..
```